

ergoselect 4 / 5

Ergometer

Operator's Manual

201000433000 • Version 2024-09-12 / Rev 09 • English



Manual

ergoselect 4 / 5

Ergometer

Operator's Manual

201000433000 • Version 2024-09-12 / Rev 09 • English

This manual was written with the utmost care. Should you still find details that do not correspond with the system, please let us know and we will correct the issue as soon as possible.

We reserve the right to modify the design and technical features of the device and are not bound by the information and illustrations provided in this manual.

All trademarks appearing in this document are trademarks of their respective owners. Their protection is acknowledged.

No part of this manual may be reprinted, translated or reproduced without the manufacturer's written permission.

This manual will not be automatically updated. Please contact the manufacturer for the latest document revision.

This manual also describes optional components that are not included in the standard scope of delivery of this product.

The document "Cleaning, and Disinfecting ergoline Medical Devices" (Part No. 201000641000) in its most recent version is also part of this manual. This document is exclusively made available for download from the ergoline website www.ergoline.com.

ergoline GmbH
Lindenstrasse 5
72475 Bitz
Germany

Tel.: +49-(0)-7431 - 9894 - 0
Fax: +49-(0)-7431 - 9894 - 128
e-mail: info@ergoline.com
http: www.ergoline.com



Contents

1	General Information	5
2	Safety Information – Basic Device	6
2.1	Indications, Contra-indications, and Exclusion, Criteria for Termination	8
2.2	Intended Use	9
2.3	Clinical Benefit	9
2.4	Intended User/Operator	9
2.5	Intended Patient Group	9
2.6	Biocompatibility	9
3	Symbols	10
4	Setup and Mains Connection	12
4.1	Controls and Indicators	12
4.2	Transport	13
4.3	Setup	13
4.4	Mounting the Control Terminal	14
4.5	Mounting the Leadwire Holder	14
4.6	Connecting the Power Cord	15
4.7	Data Interfaces	16
4.8	Connecting ECG Leadwires	17
4.9	Connecting the Blood Pressure Cuff	17
4.10	Connecting the SpO ₂ Sensor	18
5	Applied Parts	19
5.1	ECG	19
5.1.1	Contraindications	19
5.1.2	Intended Purpose	19
5.1.3	Safety Information	19
5.1.4	Disposable Electrodes	20
5.1.5	Suction electrode system	20
5.1.6	Checking the ECG Signal	21
5.2	Blood Pressure Module	21
5.2.1	Contraindications	21
5.2.2	Intended Purpose	21
5.2.3	Safety Information for Non-Invasive Blood Pressure Measurement	22
5.2.4	Cuff Size	22
5.2.5	Applying the Cuff	23
5.2.6	Microphone Position	24
5.2.7	Checking the Cuff Tubing	25
5.3	SMARTsat® SpO ₂ Module	26
5.4	Heart Rate Monitoring System	28
5.4.1	Contraindications	28
5.4.2	Intended Purpose	28
5.4.3	Safety Information	29
5.4.4	ergoline Digital Chest Strap	29
5.4.5	Polar Chest Strap	30

6	Operation	31
6.1	Speed Readout	31
6.2	Handlebar Adjustment	31
6.3	Saddle Adjustment	32
6.3.1	Motor-Assisted Saddle Adjustment	32
6.3.2	Mechanical Saddle Adjustment	33
6.3.3	Saddle Adjustment with Gas Pressure Spring	33
7	Control Terminal M	34
7.1	Turning the System On	34
7.2	Operating Mode with Control Terminal M	34
8	Control Terminal P	36
8.1	Turning the System On	36
8.2	Operating Modes with Control Terminal P	37
8.2.1	PC Mode	37
8.2.2	Ergometry	38
8.2.3	Manual	40
8.2.4	Settings with Control Terminal P	41
9	Control Terminal T	47
9.1	Turning the System On	47
9.2	Operating Modes with Control Terminal T	48
9.2.1	PC Mode	49
9.2.2	Ergometry	51
9.2.3	Training/Test	54
9.2.4	Training with Chip Card	64
9.2.5	Manual	68
9.2.6	Setup	69
10	Accessory/Compatible Devices	80
10.1	Accessories Overview	80
10.2	Compatible Devices	81
11	Cleaning, Disinfection and General Hygiene Measures	82
12	General Product Information	83
12.1	Checks Before Each Use	83
12.2	Technical Safety Inspections and Inspections of the Measuring System	83
12.3	Disposal	84
13	Technical Specifications	85
13.1	Ergometer	85
13.2	Blood Pressure Module [Option B]	87
13.3	SpO ₂ Module [Option S]	87
13.3.1	Functional measurement range	87
13.3.2	Accuracy	88
13.3.3	Response Time	88

13.4 ECG Module [Option A]	88
13.5 Exercise Test Protocols	89
13.6 Test Protocols (control terminal T only)	89
13.7 Family of characteristics of the braking torque control range	90
13.8 Family of characteristics of the load periods according to IEC 60601-1	90

14 Electromagnetic Compatibility EN 60601-1-2 91

1 General Information

 DANGER
<i>Indicates an imminent hazard. If not avoided, the hazard will result in death or serious injury.</i>

 WARNING
<i>Indicates a hazard. If not avoided, the hazard may result in minor injury and/or product/property damage.</i>

 CAUTION
<i>Indicates a potential hazard. If not avoided, the hazard may result in minor injury and/or product/property damage.</i>

- If unauthorized individuals open the control terminal, damaging the calibration sticker, any warranty claim shall become void.
- This manual reflects the device specifications and applicable safety standards valid at the time of printing. All rights are reserved for devices, circuits, techniques, software programs, and names appearing in this manual.
- On request ergoline will provide a Field Service Manual.
- The implemented quality management system covers all aspects of the ergoline operations as per EN ISO 13485.
- To ensure patient safety, the specified measuring accuracy, and interference-free operation, we recommend using only original ergoline accessories. The user is responsible if accessories from other manufacturers are used.
- ergoline is responsible for the safety, reliability, and performance of the device, only if
 - modifications and repair are carried out by ergoline GmbH or by an organization expressly authorized by ergoline GmbH
 - the device is used in accordance with the instructions given in this operator manual.
- The functions described in this manual refer to ergo-meters with firmware version EF 2.3 and higher.
- The product ergoselect bears the CE marking CE-0123 (Notified Body: TÜV), indicating its compliance with the provisions of the Council Directive 93/42/EEC about medical devices and fulfills the essential requirements of Annex I of this directive.
The CE marking covers only the accessories listed in the Order Information chapter.
The device is a class IIa product.
- The device fulfills the requirements of the standard EN 60601-1 "Medical electrical equipment, Part 1: General Requirements for Safety" as well as the interference protection requirements of standard EN 60601-1-2 "Electromagnetic Compatibility – Medical Electrical Devices".
The radio-interference emitted by this device is within the limits specified in EN 55011, class B.
- This manual is an integral part of the device. It should be available to the device operator at all times. Close observance of the information given in the manual is a prerequisite for proper device performance and correct operation and ensures patient and operator safety. Please note that information pertinent to several chapters is given only once. Therefore, read the manual once carefully in its entirety.
- Observance of the safety information protects from injuries and prevents inappropriate use of the device. All device users and persons responsible for assembly, maintenance, inspection, and repair of the device must read and understand the content of this manual, before using the device or working with it. Paragraphs with special symbols are of particular importance.

2 Safety Information – Basic Device

 **DANGER**

Explosion Hazard

The device is not designed for use in areas where an explosion hazard may occur.

Explosion hazards may result from the use of flammable anesthetics, skin cleansing agents, or disinfectants.

 **WARNING**

Patient Hazard, Equipment Damage

Do not expose the ergoselect to direct sunlight to prevent system components from reaching inadmissible high temperatures.

Do NOT use the ergoselect outdoors (medical device). Furthermore, the device has no additional protection against the ingress of humidity. Humidity inside the device may cause equipment malfunctions and increases the risk of an electric shock.

Additionally, the device should not be operated in the vicinity of power systems, because they may impair equipment functions.

The ergoselect may only be used in combination with accessories approved by ergoline GmbH.

Personal Injury

Before using the ergometer, the user must ascertain that it is in correct working order and operating condition. The cables and connectors, in particular, must be checked for signs of damage. Damaged parts must be replaced immediately.

Equipment Malfunction

Only the special shielded cables supplied by ergoline may be used to connect the device to other pieces of equipment.

Equipment Malfunction

Cellular telephones may not be used in the immediate vicinity of the ergometer, because they might interfere with the proper functioning of the ergometer.

Electromagnetic interference most probably exists when the watt reading is unstable. If the displayed value changes frequently even though the speed is above 30 RPM, this may be due to electromagnetic interference.

 **WARNING**

Shock Hazard

When the device is connected to other equipment or if a medical system is created, it must be ensured that the added leakage currents do not present a hazard. In case of questions, please contact your ergoline dealer or the ergoline GmbH Service Department.

For use, the ergometer must always be connected to electric installations that fulfill the local requirements.

Patient Hazard

The German Medical Device Operator Ordinance (MPBetreibV, § 4) demands that users

- *must be trained in the use of the ergometer*
- *must be familiar with the routines for handling and assembly of the ergometer*
- *must be familiar with and observe the safety rules and regulations for operation of this type of equipment*
- *must be informed about any other pertinent rules and regulations (e.g., safety instructions)*
- *must be informed about the potential hazards arising from the use of this type of equipment*
- *must make sure that no unauthorized changes are carried out.*

Patient Hazard

The medical device is only intended for use by trained and appropriately qualified staff.

 **CAUTION**

Additional equipment connected to medical electrical equipment must comply with the respective IEC or ISO standards (e.g., IEC 62368 for data processing equipment). Furthermore, all configurations must meet the requirements of the applicable medical systems standards (see 3rd edition of IEC 60601-1).

Anybody connecting additional equipment to medical electrical equipment configures a medical system and is therefore responsible for the system's compliance with the requirements for medical electrical systems. Users are reminded that local laws take priority over the above mentioned requirements.

If in doubt, please consult your local dealer or ergoline GmbH.

WARNING

- The SpO₂ module should only be used for the purpose and in the manner described in this manual.
- The device must only be used by suitably qualified or trained personnel or under the supervision of trained personnel.
- To avoid incorrect measurements, injury to patients or damage to the device, operate the device under the specified environmental conditions only.
- For the SpO₂ measurement, the monitor uses red and infrared light with specific fixed wavelengths. Consider that these wavelengths might influence diagnostic parameters of other optical applications. The specifications of the wavelengths used are listed in the 'Instructions for Use' of the specific sensor.
- Certain environmental and physiological conditions, medical procedures, sensor application errors and external agents may interfere with the ability of SMARTsat[®] to detect and display accurate measurements.
- Only operate the device at the specified environmental conditions to prevent wrong measurement results, patient injury or damage to the device.
- Do not apply excessive tension to any of the monitor cables.
- Any radio frequency transmitting equipment or other nearby sources of electrical noise may result in disruption of the monitoring system.
- To prevent damage, avoid undue bending of the sensor cable.
- Use of this equipment adjacent to or stacked with other equipment should be avoided because it could result in improper operation. If such use is necessary, this equipment and the other equipment should be observed to verify that they are operating normally.
- Portable radio frequency communications equipment (including peripherals such as antenna cables and external antennas) should be used no closer than 30 cm (12 inches) to any part of the host monitor, including cables specified by the manufacturer. Otherwise, degradation of the performance of this equipment could result.
- The use of accessories, sensors, and cables other than those specified or provided by bluepoint Medical could result in increased electromagnetic emission or decreased electromagnetic immunity of this equipment and result in improper operation.
- Only use the compatible SpO₂ sensors listed in this document to prevent patient injury.
- Do not use sensors, cables or lines that appear to be damaged by transport or other means. Do not use sensors when optical components are exposed. Do not use a sensor or cable that appears damaged. Replace it immediately in cases of visible damage.
- If you are uncertain about the accuracy of any measurement, check the patient's vital signs by alternative means, then ensure that the device is functioning correctly.

WARNING

- A functional tester (like Index II or equivalent) may not be used to validate SpO₂ accuracy. A functional tester can be used to verify the function of pulse oximeter probes.

NOTICE

Only the removal of the power cord will result in an all-pole disconnection of the device from the power line.

2.1 Indications, Contra-indications, and Exclusion, Criteria for Termination

Indications

- Asymptomatic subjects
 - diagnosis of latent disease and of possible risks in sport
 - assessment of physical performance ability and counseling before the start of training; monitoring and guidance of training
 - assessment of performance capacity and physical performance ability in occupational medicine
- Patients with ...
 - diagnosis of cardiovascular and pulmonary disease
 - evaluation of symptoms: dyspnea, chest pain, palpitations, dizziness (syncope)
- Follow-up assessment during training (for patients as well):
 - recommendations on the extent and intensity of training
 - in accordance with the above, the diagnostic objectives are the assessment of performance, development, suitability, and structure; stress is measured by external parameters and effort by "internal" ones as a response of the subject's organs to the task.

Contra-indications and exclusions

- Absolute
 - any acute or severe chronic cardiorespiratory disease causing marked functional impairment (e.g., severe congestive heart failure, high-grade congenital heart defects, cardiomyopathy, severe arrhythmias, thromboses, malignant hypertension, or pulmonary hypertension)
 - any acute or severe disease of other organ systems, e.g., nephritis, poorly controlled diabetes mellitus, or electrolyte disturbances
 - febrile infections
 - musculoskeletal and neuromuscular disorders that preclude safe and adequate test performance
- Relative
 - known obstructive left main coronary artery stenosis
 - moderate to severe aortic stenosis with uncertain relation to symptoms
 - tachyarrhythmia or bradyarrhythmia with uncontrolled ventricular rate
 - moderate to severe valvular heart disease
 - acquired advanced or complete heart block
 - hypertrophic obstructive cardiomyopathy with severe resting gradient
 - recent stroke or transient ischemic attack

- age or mental impairment leading to inability to cooperate
- resting hypertension with systolic or diastolic blood pressures > 200/110 mmHg
- uncorrected medical conditions, such as significant anemia, important electrolyte imbalance, and hyperthyroidism
- ventricular aneurysm

Criteria for termination

- Subjective symptoms
 - dizziness
 - incoordination
 - progressive chest pain
 - shortness of breath
 - pain in the legs or disability to perform the test
- Objective signs
 - ECG changes
 - progressively severe arrhythmias
 - progressive intracardiac conduction disturbance
 - progressive repolarization disorder
 - hemodynamic changes
 - progressive drop in blood pressure
 - insufficient rise in blood pressure
 - excessive rise in blood pressure
 - abnormal findings during auscultation of the lungs (e.g., breath sounds such as cawing, wheezing)

Complications secondary to exercise testing

- Cardiac
 - Bradyarrhythmias
 - Tachyarrhythmias
 - Acute coronary syndromes
 - Heart failure
 - Hypotension, syncope, and shock
 - Death (rare; frequency estimated at 1 per 10.000 tests, perhaps less)
- Non-cardiac
 - Musculoskeletal trauma
 - Soft-tissue injury
- Miscellaneous
 - Severe fatigue (malaise), sometimes persisting for days
 - Dizziness
 - Body aches
 - Delayed feelings of illness

2.2 Intended Use

The medical device is an ergometer used to apply stress to a patient's cardiovascular and musculoskeletal systems and for exercise training.

2.3 Clinical Benefit

In cardiac rehabilitation and secondary prevention programs with the medical device, patients benefit from training by improving their physical capacity and, at the same time, by reducing the probability of recurrence of medical conditions such as cardiovascular diseases, metabolic disorders, cancers, pulmonary diseases or diseases resulting from a sedentary lifestyle. Furthermore, the medical device can be used as a diagnostic device in stress ergometry and exercise testing.

2.4 Intended User/Operator

Only the intended users are allowed to use the ergometer.

Intended users/operators are, among others, healthcare professionals thoroughly instructed on the basis of the operator manual, such as

- physicians
- healthcare providers
- therapists

The group of intended users does not include persons whose mental and physical capabilities and skills have an adverse effect on their ability to use the medical device in accordance with its intended purpose.

2.5 Intended Patient Group

The intended patient group includes all persons











- with a maximum weight of up to 200 kg
- whose body height and age makes them eligible for exercising on the ergometer. Due to various ergonomic aspects, it is not possible to provide exact data for body height and age.
- whose medical condition has been checked by a medical specialist who judged them to be suitable for the application described in the intended use.













2.6 Biocompatibility

The parts of the product described in this manual, including all accessories that come in contact with the patient during the intended use, fulfill the biocompatibility requirements of the applicable standards if used as intended.

If you have questions in this matter, please contact ergoline GmbH or an ergoline representative.

3 Symbols

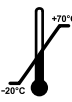
-  Symbol 'type B applied part'.
Type B applied parts have no direct contact with patients and offer the lowest protection against electric shock.
-  Symbol 'type BF applied part'.
Type BF applied parts are connected to the body of the patient and provide a higher degree of protection against electric shock. The applied parts are isolated.
-  Observe the information given in the operator's manual.
-  Protection class II equipment.
-  This symbol indicates that the waste of electrical and electronic equipment must not be disposed of as unsorted municipal waste and must be collected separately.
- REF** Order number/catalog number.
- SN** Serial number.
-  Scheduled date of the next inspection (e.g., March 2024).
-  Toggle switch ON (voltage).
-  Toggle switch OFF (voltage).
-  Button to adjust the handlebar height
 △ Handlebar UP
 ○ Toggle switch OFF
 ▽ Handlebar DOWN
- CE 0123** CE mark per the Medical Device Directive 93/42/EEC of the European Union.
Notified body: TÜV SÜD Product Service GmbH, Ridlerstr. 65, 80339 München, Germany.
-  Nationally Recognized Testing Laboratory NRTL label for the USA and Canada.
-  Do not lean against device: tipping hazard.

-  Manufacturer.
-  Date of manufacture.
The number found under this symbol is the date of manufacture in the YYYY-MM-DD format.
-  PVC-free.
-  Suitable for the indicated arm circumference.
-  Small size.
-  Standard size.
-  Large size.
- MD** Medizinprodukt
-  Distributor
- CH REP** Authorized representative in Switzerland
- Rev.** Current Revision Number
-  Transport and storage label: top.
-  Transport and storage label: keep dry.
-  Transport and storage label: fragile, handle with care.
-  Transport and storage label: temperature limits.
-  Transport and storage label: humidity limits.

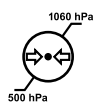

Transport and storage label:
atmospheric pressure limits.



Transport and storage label:
do not stack.



Consult operator's manual.



Prescription only. Caution: U.S. Federal Law restricts
this device to sale by or on the order of a physician.



Not made with natural rubber latex.



Not made with DEHP.



Do not throw away.



Do not use if package is open or damaged.



MR unsafe.



Keep away from sunlight.



Batch code/Lot number.

4 Setup and Mains Connection

4.1 Controls and Indicators

- 1 Control terminal M
- 2 Speed readout for patient
- 3 Connectors (e.g., for blood pressure cuff)
- 4 Adjustment of handlebar angle
- 5 Castors
- 6 Base plate (small)
- 7 Leveling feet to adjust the ergometer to uneven floors
- 8 Sockets for power cord and connection cables (underside of ergometer)
- 9 Power switch (toggle switch [I/O])
- 10 Saddle adjustment with clamping lever



Figure 4–1: ergoselect 4M

- 1 Control terminal T
- 2 Speed readout for patient
- 3 Connectors (e.g., for blood pressure cuff, SpO₂)
- 4 Adjustment of handlebar angle
- 5 Height adjustment for handlebar (by means of toggle switch, option)
- 6 Castors
- 7 Baseplate (large)
- 8 Leveling feet to adjust the ergometer to uneven floors
- 9 Sockets for power cord and connection cables (underside of ergometer)
- 10 Power switch (toggle switch [I/O])
- 11 Saddle adjustment (optionally with gas pressure spring or motor)



Figure 4–2: ergoselect 5T

4.2 Transport

For short distances, the ergometer can be lifted at the saddle and rolled away on its castors.

To cover greater distances, however, we recommend the following method:

- Disconnect the power cord and the connection cables.
- Rotate the handlebar towards the front and tighten the clamping lever.
- Stand in front of the ergometer, grasp the handlebar and tilt the ergometer towards you until it is standing on the castors only and is balanced.
- It is now possible to transport the ergometer.
- When you have reached the new location, lower the ergometer very carefully to protect it from considerable damage.



Equipment Damage

Avoid strong vibrations of the ergometer during transport.



Figure 4-3: ergoselect

4.3 Setup

Place the ergometer on a horizontal level floor.

The ergometer must be set up in a secure and stable position; the two leveling feet at the back make for easy adjustment to uneven floors. An optional anti-tipping device is available to enhance the stability.

Extend the foot concerned until the ergometer no longer wobbles.

In case of delicate flooring, it is recommended to place a mat under the ergometer to protect the flooring from damage by the feet.

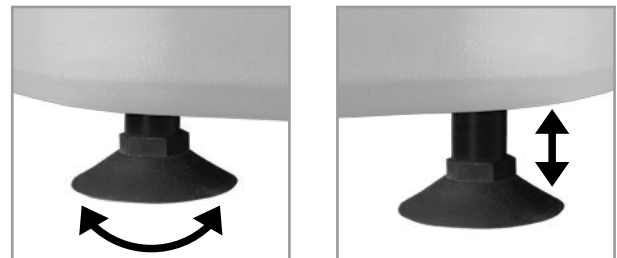

Figure 4-4: Leveling feet of the ergometer

4.4 Mounting the Control Terminal

The control terminal can be installed with the display facing either the patient or the operator.

It is recommended to install the terminal with the display and control keys towards the operator and the speed read-out towards the patient.

NOTICE

Only a specialist dealer is allowed to change the orientation of the control terminal. If the control terminal is mounted inappropriately, the tubing and cables may be bent or damaged. The device will only operate correctly if the tubing and cables are properly arranged.

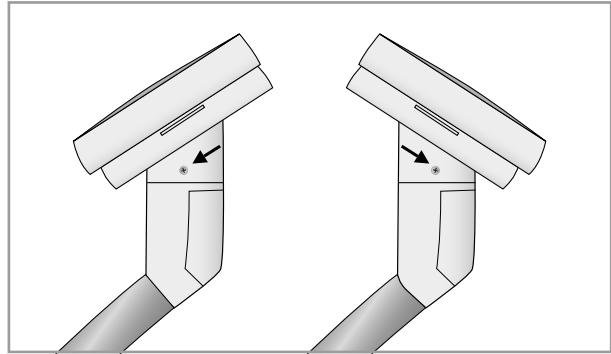

Figure 4-5: Different orientations of the control terminal

4.5 Mounting the Leadwire Holder

Using the height spacer **1** and 2 Allen screws with washers **3**, screw the gooseneck **2** to the sides of the control terminal adapter.

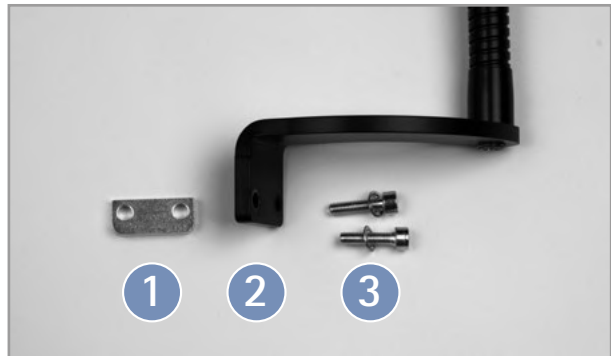

Figure 4-6: Leadwire holder components



Figure 4-7: Mounting the leadwire holder

4.6 Connecting the Power Cord

Stand in front of the ergometer (looking at the control panel) and firmly grasp the handlebar with both hands.

Then tilt the ergometer carefully to one side (it is recommended to do this with the help of a second person) and place it on the floor so that it rests on the handlebar.



Figure 4-8:

CAUTION

Equipment Damage

Before connecting the ergometer to the power line, check that the line voltage corresponds to the ratings on the type plate.

The type plate is located on the back of the device, at the bottom.

The connection panel is located on the underside of the ergometer.

- Connect the power cord to socket **1**.
- Using the supplied strain relief, attach the power cord to the metal frame **2**.

Return the ergometer carefully to its upright position and make sure that it is not standing on the power cord.

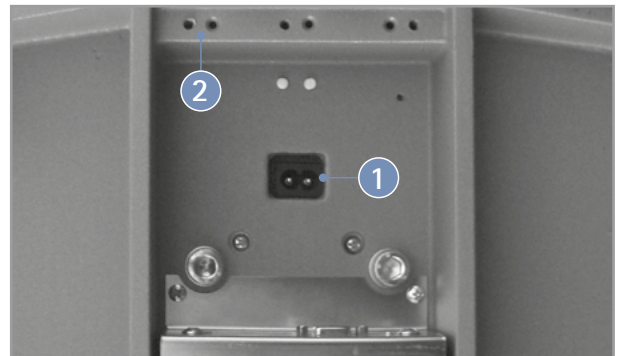

Figure 4-9: Underside of the ergometer

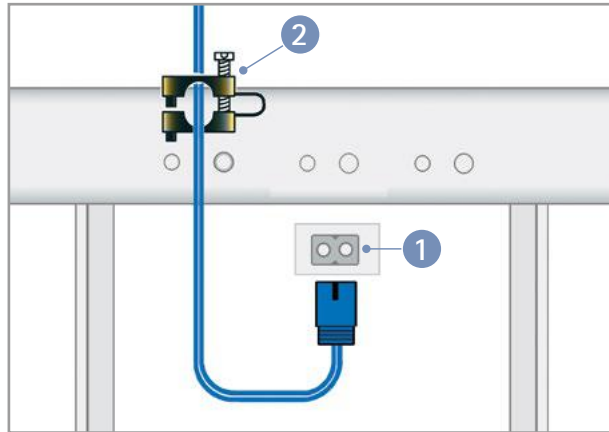

Figure 4 – 10: Connecting the power cord

- ① Power input
- ② Strain relief

NOTICE

Disconnection from Power Supply

Pressing the power switch or removing the power cord disconnects the device from the power supply.

Removing the power cord results in a complete disconnection of the device from the power supply (all poles).

Ensure that the power plug is readily accessible at all times.

4.7 Data Interfaces

The ergometers are prepared for a functional connection with a PC or a medical electrical device (ME device) via USB or serial interface.

Different connection cables are available to support different communication modes (digital, analog, remote start, etc.).

All ergometers are equipped with a digital interface. (Special adapters are needed for analog control or the remote start capability. Please contact ergoline for these adapters.)

The connection cable is plugged into the 9-pole socket of the connection panel (Port 1) or the USB port and secured at the metal frame with an additional strain relief.

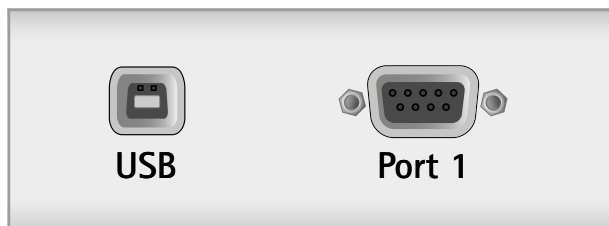

Figure 4 – 11: Connection to electrocardiograph/PC-based ECG system

- USB PC connection via USB (virtual COM)
- PORT 1 Digital connection (remote control from PC or ECG recorder), connection for cable adapter (analog interface + remote start)

NOTICE

Connection Cables

Use only connection cables approved by ergoline.

A special PC driver software, which can be obtained from ergoline, is required for operation via the USB port. The driver can be downloaded at the internet page

<https://www.ergoline.com/en/software.html> section DRIVERS (EN) or use the QR code.



4.8 Connecting ECG Leadwires

Plug the ECG leadwires (R, N, L) into the appropriate sockets 1 in the control terminal, observing the color codes on the leadwires and ergometer.

NOTICE

Connecting the leadwire to the wrong socket may cause an incorrect ECG signal.

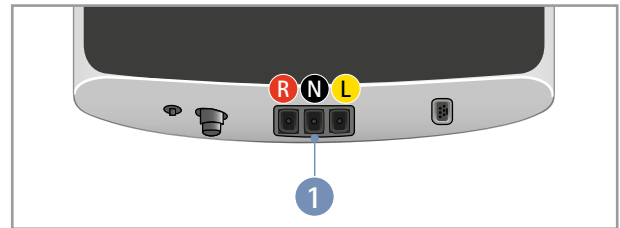

Figure 4-12: ECG leadwire connections

NOTICE

Only available with control terminal T.

4.9 Connecting the Blood Pressure Cuff

- Connect the microphone cable for blood pressure measurement to the intended port 1 so that it clicks into place.
- Slip the cuff tubing onto the fitting 2 and engage. To disconnect, push back the connector's knurled sleeve.

Artifacts must be avoided while the blood pressure is being taken. They may be caused by patient movements during the exercise test.

Therefore, do not forget to attach the cuff tubing to the handlebar with the supplied Velcro tape:

- Open the large Velcro tape and wrap it around the handlebar.
- Secure the cuff tubing with the small Velcro tape, but do not exert pressure on the tubing.

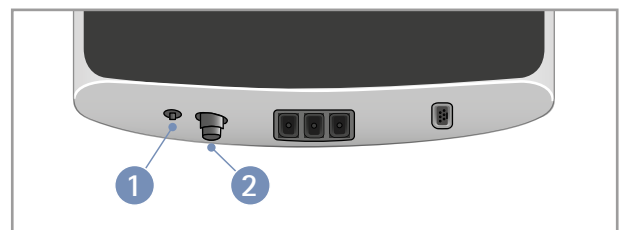

Figure 4-13: Blood pressure cuff connections

- 1 Microphone connection
- 2 Fitting for connection of cuff tubing

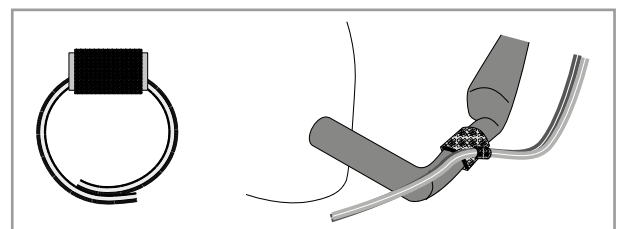

Figure 4-14: Velcro tape to secure the cuff tubing

4.10 Connecting the SpO₂ Sensor

Before application and use, check the SpO₂ sensor and its package for damage. Do not use the sensor if you detect any signs of damage.

Connect the sensor cable to the corresponding socket ① on the underside of the control terminal.

NOTICE

Please observe the accompanying documents for the SpO₂ sensor.

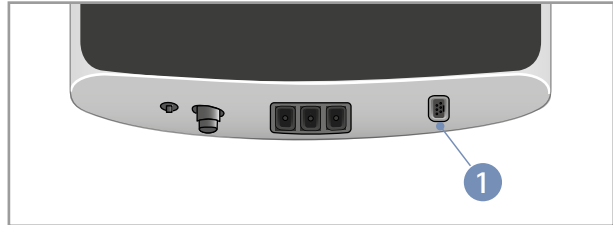

Figure 4 – 15: Connecting the oxygen saturation sensor
① SpO₂ port

5 Applied Parts

5.1 ECG

5.1.1 Contraindications

- The general, absolute contraindications to cardiac stress testing (according to the ergometry guidelines, DGSP (German Sports Physicians Association)) apply.
 - Acute myocardial infarction
 - Unstable angina
 - Cardiac arrhythmia causing symptoms and/or hemodynamic instability
 - Symptomatic severe aortic stenosis
 - Decompensated heart failure
 - Acute pulmonary embolism
 - Acute myocarditis
 - Acute pericarditis
 - Acute aortic dissection
- Patients with physical, psychological, or mental afflictions who cannot be mobilized and are therefore not capable of using rehabilitation facilities.

5.1.2 Intended Purpose

The ECG module is a device for recording of a single-channel, bipolar surface ECG (frontal plane) acquired with three ECG electrodes. It is used to continuously monitor the heart rate and the cardiac rhythm and to control the training load for patients in rehabilitation or preventive training programs.

The signal is acquired on the intact skin of patients.

The medical device is intended for use in professional healthcare institutions for inpatient and outpatient care.

5.1.3 Safety Information



WARNING

No monitoring device

There is a risk of life-threatening patient conditions going unnoticed.

The ECG system is not suitable for the electrocardiographic monitoring of critical care patients.

No pacemaker detection

There is a risk of inadequate therapy and/or over-exertion.

The ECG module may continue to count the pacemaker rate during cardiac arrest or in the presence of some arrhythmias.

Do not rely entirely upon rate meter alarms.

The ECG module has no pacemaker pulse rejection capability.

Keep pacemaker patients under close surveillance. The primary user is required to periodically assess the current exertion level by referring to independent, subjective parameters (e.g., the RPE value).

No defibrillation protection

The ECG module is not an applied part with defibrillation protection. Before a defibrillation pulse is released, the ECG leadwires must be removed from the patient because it CANNOT be excluded that they conduct the defibrillation energy to the ECG module.

Conductive materials

Electric shocks or malfunction of the ECG system may result from contact with conductive materials.

Conductive parts of the ECG system must not touch other conductive parts, including ground, during application to or removal from the patient.

Follow the sequence of steps for application and removal of the ECG system described in this manual.

Visual inspection before use

Before each use, visually inspect the ECG system for signs of damage. If you detect damage that may result in a hazard to the patient or the operator, the ECG system must be repaired before it can be used again. Follow the instructions for visual inspection given in this manual.

5.1.4 Disposable Electrodes

NOTICE

- Only commercially available stress test ECG electrodes approved for medical application may be used for ECG acquisition.
- Keep the electrode contacts away from other conductive parts.

- Attach disposable electrodes (see figure 5 – 1)
- Connect leadwires with snap fastener to the electrodes
- Place leadwires in gooseneck holder

5.1.5 Suction electrode system

NOTICE

Higher suction levels may cause hematomas or skin irritation in patients with sensitive skin. Check that the suction level is appropriate for the patient. In the case of patients with medical conditions such as arterial occlusive disease or severe blood coagulation disease, the physician must decide whether or not to use the device.

- Switch on the suction electrode system and select the "middle" level (see section "ECG Mode" on page 49)
- Prepare the skin for electrode placement with contact spray (ergofluid)
- Attach the electrodes (see figure 5 – 1), briefly tap on the electrode to generate suction: the pump starts up
- Adjust the vacuum intensity if necessary (see section "ECG Mode" on page 49)

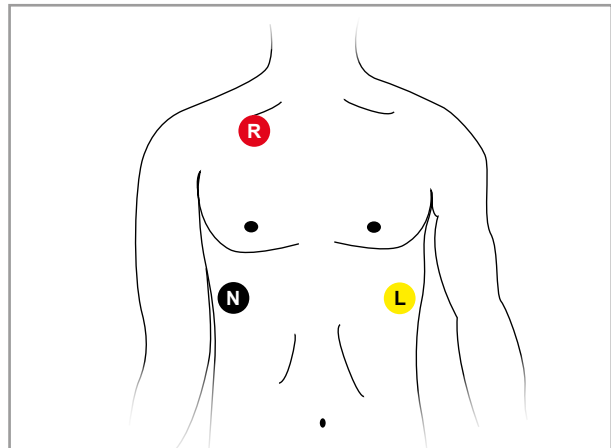

Figure 5 – 1: ECG electrode placement

NOTICE

- Do not spray the contact agent onto the electrodes or lead-wires.
- Do not under any circumstances use water or contact gel.
- Use only the recommended contact spray (ergofluid).

5.1.6 Checking the ECG Signal

After electrode placement, the quality of the acquired ECG signal can be directly assessed on the display of the control terminal. If the ECG signal is too weak or shows too many artifacts, please correct the electrode placement.

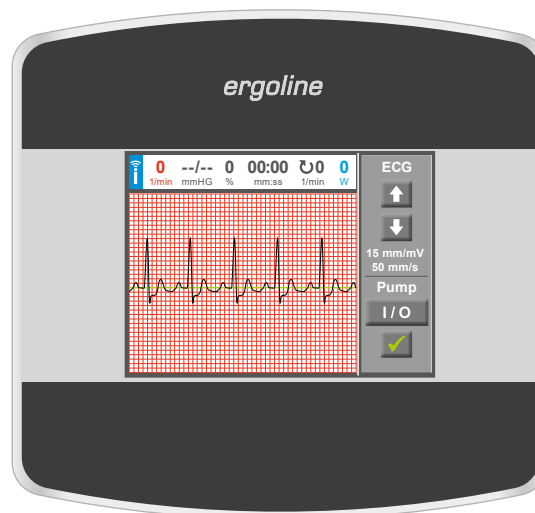

Figure 5-2: Checking the ECG signal

5.2 Blood Pressure Module

5.2.1 Contraindications

- The BP module is not intended for use in ICUs or ambulances.
- The BP module is not intended for neonates or pregnant women.
- The BP module may not be used simultaneously with HF surgical devices.
- The BP module may not be used in MR environments.

5.2.2 Intended Purpose

The ergoline blood pressure module is intended to measure the systolic and diastolic blood pressure on the upper arm at rest and during dynamic exercise by a non-invasive, auscultatory method.

The medical device is intended for use in professional healthcare institutions for inpatient and outpatient care.

The signal is acquired on the intact skin of patients.

5.2.3 Safety Information for Non-Invasive Blood Pressure Measurement

Contraindications:

- sickle cell anemia
- skin lesions

The following factors may have an effect on blood pressure measurements:

- cardiac rhythm disturbances (arrhythmias)
- arteriosclerosis
- low perfusion
- diabetes
- age
- pregnancy
- pre-eclampsia
- renal diseases
- patient motion, trembling, shivering
- environment (extreme temperatures, humidity, altitude (m above sea level) and electromagnetic fields)

Frequent measurements can impair perfusion and may considerably harm the patient.

NOTICE

- If the cuff pressure exceeds the maximum value of 300 mmHg during inflation, the inflation procedure will be aborted and the cuff deflated.
- As a redundant safety precaution, the cuff is immediately deflated when the cuff pressure exceeds 320 mmHg.
- You can check the proper functioning of this safety precaution by abruptly bending your arm while the cuff is being inflated, causing a brief overpressure in the cuff. The cuff must deflate immediately.
- Measurements that do not yield a valid measurement will not be repeated during the exercise test.
- If the inflation phase takes longer than 40 seconds or if an adequate pressure does not build up in the cuff within a reasonable period of time, the measurement will be aborted and the cuff deflated.
- If a valid measurement cannot be completed within 120 seconds, the measurement will be aborted and the cuff deflated.
- If the cuff pressure remains constant for some time, the measurement will also be aborted and the cuff deflated.

5.2.4 Cuff Size

The cuff is only intended for application on the upper arm (left/right).

The maximum arm circumference is indicated on the cuff.



WARNING

Do not apply the cuff on a lesion because this may entail further damage.

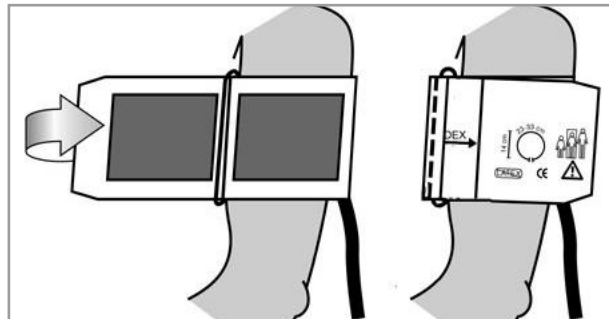

Figure 5 – 3: Correct cuff size

5.2.5 Applying the Cuff

WARNING

Lymphedema may occur in the arm concerned after lymph node removal and can be promoted by inflation of the cuff. Therefore, it is not recommended to apply a blood pressure cuff on the arm with lymphedema.

The cuff should not be placed on the arm on the side of a mastectomy. Inflation of the cuff can cause pain, trauma and/or further injuries in the arm on the affected side of the body. In patients who had a unilateral mastectomy, the blood pressure can be obtained on the contralateral arm.

When you close the Velcro strap, check that the metal clasp

① is inside the marked index range ②, and not outside.

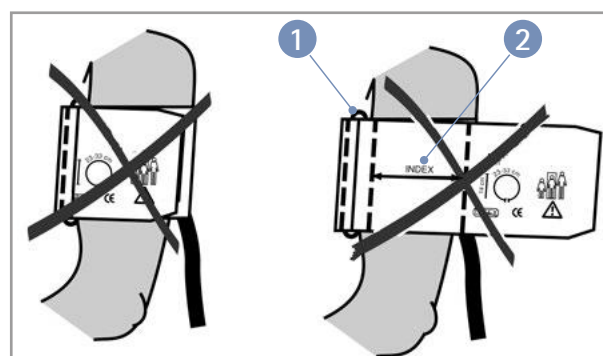

Figure 5-4: Wrong cuff size

CAUTION

- A cuff not directly applied on intact skin can cause incorrect measurements. Be sure to apply the cuff exactly as described in this manual.
- Cuffs applied below a rolled-up sleeve may further compress the upper arm and cause incorrect measurements. Check that only the cuff compresses the upper arm.
- If the cuff is applied too loosely, the measurement result will be incorrect.

CAUTION

Patient Hazard

- If the applied cuff is too tight, it may constrict blood vessels or cause skin lesions and hematomas.
- The cuff may cause hematomas in patients with severe blood coagulation disease. In these instances, the user must take a decision for or against automatic blood pressure measurements.

5.2.6 Microphone Position

Before applying the cuff, check the position of the microphone inside the red pocket (on the inside of the cuff):

When the microphone is inside the pocket, its **metal side must face the arm**.

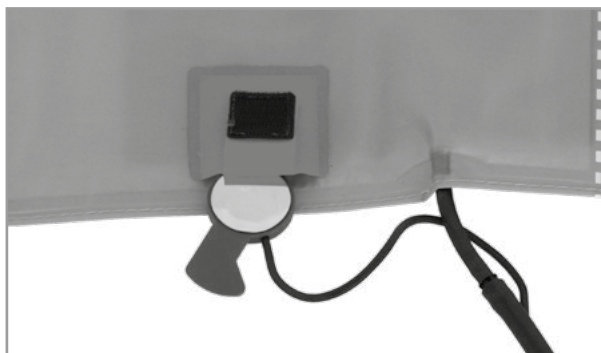

Figure 5-5: Correct microphone position

The center of the microphone must be located exactly on the **brachial artery**. Locate the artery by palpation if required.

The **red tab** identifies the position of the microphone. The accurate placement of the microphone is the primary condition for reliable pressure measurement during exercise tests. The cuff must be applied directly on the skin, it may not be applied on top of clothing, paper, etc. Apply the cuff approx. **2 cm above the bend of the elbow**. The cuff should be **tight**, but it should not constrict blood vessels. Make sure that the cuff **cannot shift** when the patient moves during the exercise test.

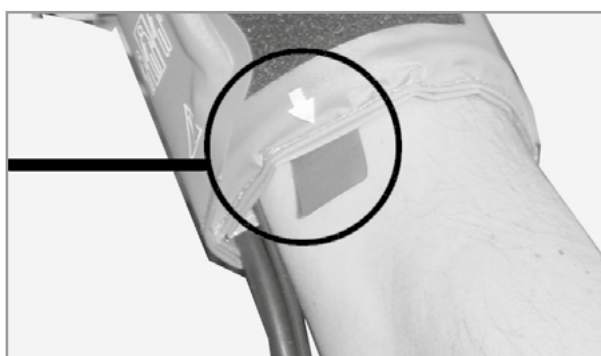

Figure 5-6: Microphone placement on the artery

The cuff tab must be located below the metal clasp (see illustration at right).

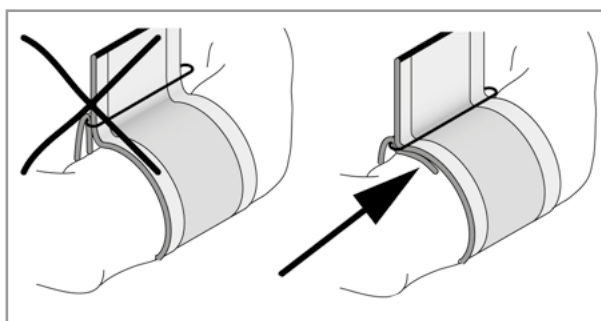

Figure 5-7: Correct cuff position (tab)

5.2.7 Checking the Cuff Tubing

Check that the cuff tubing does not knock against the patient's knee, when the patient is pedaling and the hand is on the handlebar.

Secure the cuff tubing with the Velcro tape attached to the handlebar.

Instruct your patient to move as little as possible during a blood pressure measurement and, in particular, to avoid excessive contractions of the muscles in the upper arm.

WARNING

Patient Hazard

- *Make sure that the cuff tubing will not be kinked during the exercise test. A kink in the tube may impair perfusion, which may seriously harm the patient.*
- *If, by accident, an excessive pressure builds up inside the cuff, either remove the cuff immediately from the arm or disconnect the cuff tubing from the control terminal. The same measures are recommended if the cuff does not deflate correctly.*

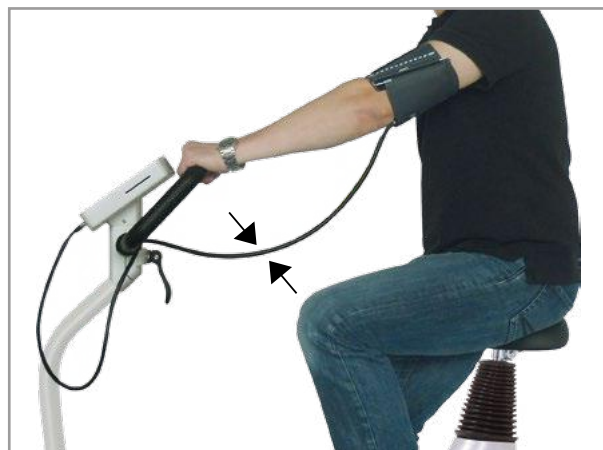

Figure 5–8: Distance between knee and tubing

5.3 SMARTsat[®] SpO₂ Module

Intended Purpose

The reusable SMARTsat[®] pulse oximetry sensors are intended to be used for non-invasive continuous monitoring and/or random monitoring of the functional oxygen saturation of arterial hemoglobin (SpO₂) and pulse rate in adults and children, depending on the sensor type used.

SMARTsat[®] is intended for use in professional healthcare facilities and in sports medicine in compliance with the safety information.

Factors that may influence Readings

Physiological conditions, medical procedures, or external agents that may degrade pulse oximeter performance or affect the accuracy of the measurement include the following:

Ambient light:

If the ambient light level exceeds a limit of compensation SMARTsat[®] interrupts the measurement and sends out the status flag "Ambient light".

NOTICE

Shield the SpO₂ sensor application site with opaque material if the measurement is interrupted and the status flag "Ambient light" is send.

Motion artefacts:

The SMARTsat[®] algorithm suppresses the influence of motion on the SpO₂ and PR measurement. However long and continuous motion can lead to wrong measurements. SMARTsat[®] provides a Signal Quality and Motion indicator to inform the user if the measurement value is potentially incorrect.

NOTICE

*Check the sensor site and prevent motion artefacts if SMARTsat[®] detects bad signal quality, motion artefacts, interferences etc. (see SMARTsat[®] status flags) Dysfunctional hemoglobin (e.g. COHb, MetHb):
High concentration of dysfunctional hemoglobin, such as COHb or MetHb, which is not able to transport oxygen can falsify the measurement. The indicated result appears to be normal but the patient may be hypoxic.*

Intravascular dyes:

Taking medicine or other preparations that change blood color or the administration of intravascular dyes (such as methylene blue or indocyanine green, etc.) can drastically falsify the measurement results.

Other:

Other conditions that may degrade pulse oximeter performance or affect the accuracy of the measurement include:

- Incorrect applications of the sensor
- Externally applied coloring agents such as nail polish or artificial nails,
- Placement of the sensor on an extremity with blood flow restrictors (arterial catheters, blood pressure cuffs, infusing lines, etc.),
- Low perfusion, venous pulsations, anemia or low hemoglobin concentrations
- Cardiac dysrhythmia like extrasystole or atrial/ventricular fibrillation
- Electromagnetic interference and electrosurgical interference

Status Messages

The SpO₂ module continuously monitors the sensor and the physiological conditions, and reports the status to the control terminal.

The status flags include:

Status Information	Reason
Connect sensor	Sensor is not connected.
Sensor off patient	Sensor has been removed from the measurement site or slipped of the measurement site (finger or ear lobe).
Pulse search > 30 s	No pulse detected for more than 30 seconds. This could be due to no pulse being present or artifacts in the signal. No SpO ₂ or pulse rate values are transmitted.
Loss of pulse	No pulse is detected and therefore no value is displayed; typically due to prolonged bad signal quality. Alarm monitors should issue at least a medium priority alarm if this bit is set.
Ambient light	Ambient light level exceeds the limit of possible compensation. The measurement is interrupted and the flag is sent.
Param out of range	Vital parameter out of range: Measurement values are invalid because they are outside the specified measurement range. Possible reasons include the use of intravascular dyes.
Replace sensor	The sensor, its cable or the optical components are defective. The measurement is interrupted. Remove the sensor to reset the flag. Measurement is continued on connection of a new sensor.
SpO ₂ defect	Supply voltage out of range: The supply voltage provided to the module is outside of the specified range. Under these conditions the measurement values are potentially incorrect.

Alarm System

The ergoselect bicycle ergometer does not have an alarm system for detecting a **physiological alarm status** (low SpO₂ or pulse rate values).

5.4 Heart Rate Monitoring System

5.4.1 Contraindications

- The general, absolute contraindications to cardiac stress testing (according to the ergometry guidelines, DGSP (German Sports Physicians Association)) apply.
 - Acute myocardial infarction
 - Unstable angina
 - Cardiac arrhythmia causing symptoms and/or hemodynamic instability
 - Symptomatic severe aortic stenosis
 - Decompensated heart failure
 - Acute pulmonary embolism
 - Acute myocarditis
 - Acute pericarditis
 - Acute aortic dissection
- Patients with physical, psychological, or mental afflictions who cannot be mobilized and are therefore not capable of using rehabilitation facilities.

5.4.2 Intended Purpose

The heart rate module is a device for acquisition, calculation and transmission of the patient's heart rate. It is used to continuously monitor the heart rate and to control the training load for patients in rehabilitation or preventive training programs.

The signal is acquired on the intact skin of patients.

The device is intended for use in professional healthcare institutions for inpatient and outpatient care.

5.4.3 Safety Information



WARNING

- Heart rate measuring systems may be inaccurate.
- Incorrect or excessive training can have serious or even fatal consequences.
- If the patient is about to faint or feels dizzy, the training should be immediately interrupted and you should consult a physician.

5.4.4 ergoline Digital Chest Strap

- Wear the heart rate measuring device against bare skin. The entire surface of the integrated electrodes should be in direct contact with skin.
- Adjust the strap length to the chest circumference so that the strap stays in place during the training.
- Use the fastening mechanism to join one end of the strap with the transmitter unit.
- Tie the strap around your chest and fasten the other end of the strap in the same way.
- Check that the strap is snug around the body and that it is not twisted.

NOTICE

To improve contact, moisten the electrode surfaces (grooved area) on the inside with electrode gel or spray.

- The strap is placed correctly when it is tight against the body below the chest muscles/breasts. The ergoline logo must be visible on the outside of the strap and presented in the proper orientation.



Figure 5-9: ergoline digital chest strap

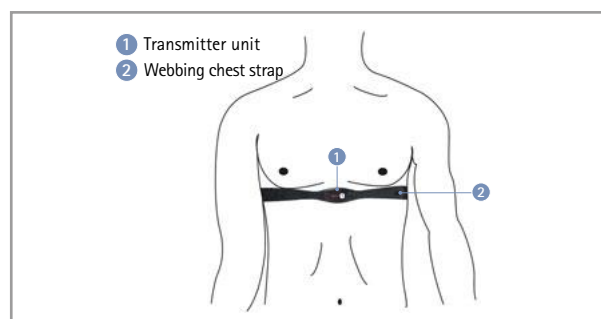

Figure 5-10: Properly applied chest strap

5.4.5 Polar Chest Strap

- Attach one end of the heart rate sensor to the elastic strap.
- Moisten the two marked areas on the back.

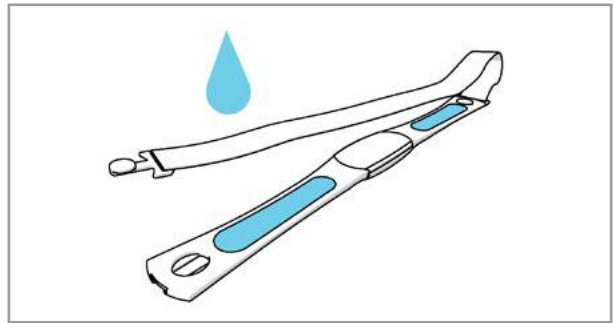

Figure 5 – 11: Fastening and moistening the chest strap

- Fasten the heart rate sensor around the chest and adjust the strap to fit snugly.
- Check that the moistened, marked areas are flat against the skin and that the text on the heart rate sensor has the correct orientation and is positioned in the middle of the chest.
- For further information, go to <https://www.polar.com/uk-en/products/heart-rate-sensors>

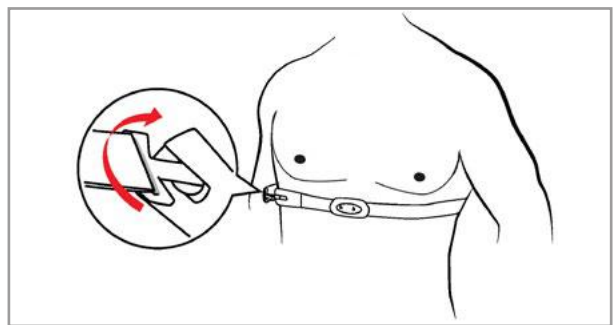

Figure 5 – 12: Applying the chest strap

6 Operation

The ergometer is available with different control terminals which differ to some extent in terms of their functionality.

The following sections describe the control and configuration of the device.

6.1 Speed Readout

A speed readout as well as three LEDs on the control terminal inform the patient of the speed: too slow, too fast or correct (this readout is located at the top of the P and T versions of the control terminal and on the side of control terminal M).

The ranges for the respective speed ratings depend on the selected load (see chapter 13 "Technical Specifications" on page 85).

NOTICE

If, during an exercise test, the speed drops below 30 RPM, the load reading starts blinking on the display and the load is reduced to zero.



Figure 6-1: Speed readout

- ① speed low (= patient should pedal faster)
- ② correct speed
- ③ speed high (= patient should pedal more slowly)

6.2 Handlebar Adjustment

To adjust the angle of the handlebar, release the clamping lever ① by pulling it upwards.

Choose a handlebar angle that allows the patient to sit up straight and comfortably. When done, push the clamping lever ① downwards for secure clamping.



Figure 6-2: Handlebar adjustment

- ① Clamping lever

Before allowing the patient to lean on the handlebar, check the clamp as follows:

DANGER

With the ergometer standing firmly, check that the handlebar is tight by trying to push the handlebar downwards from above. Adjust the clamping force of the clamping lever if necessary.

*The handlebar is not designed to support the full body weight!
Risk of falling!*



Adjust the clamping force by opening the clamping lever and turning the setting screw clockwise about a quarter revolution with a flat-blade screwdriver. Then check the clamping force. Repeat these steps if necessary. When the clamping force is appropriate, lock the clamping lever by folding it down.

The handlebar is not designed to support the full body weight.

Optionally, the height of the handlebar can be adjusted by means of a motor that is controlled via the toggle switch on the handlebar.

NOTICE

- Lock the clamping levers only as tight as necessary, NOT with maximum force.
- Lubricate the thread of the saddle clamping lever periodically with a suitable lubricant (e.g., OKS470).

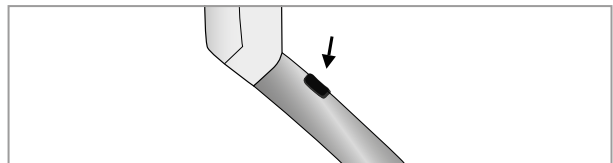

Figure 6-3: Toggle switch for adjusting the height of the handlebar

6.3 Saddle Adjustment



6.3.1 Motor-Assisted Saddle Adjustment

On the different ergometer models, the saddle height is adjusted in different ways:

- with a clamping lever (mechanical)
- with a gas pressure spring or
- with a motor.

When adjusting the height at the display, press the [Saddle] key first. Then press the appropriate arrow key on the right to raise or lower the saddle. The display indicates the current saddle height.

NOTICE

Press the [Saddle] key or the  key to enable adjustment of the saddle: the adjustment keys will be displayed (or use the  and  buttons on the control terminal).

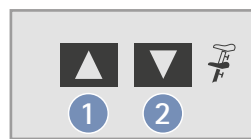

Figure 6-4: Saddle adjustment at the control terminal

- 1 Saddle up
- 2 Saddle down



Figure 6-5: Saddle adjustment at the display

- 1 Saddle up
- 2 Saddle down

6.3.2 Mechanical Saddle Adjustment

Open the clamping lever ① by turning it counter-clockwise. Then you are able to adjust the saddle height.

Adjust the appropriate saddle height as follows: Ask the patient to stand next to the saddle. Position the saddle at the level of the patient's hip. Then tighten the clamping lever ① hand tight by turning it clockwise.

Before allowing the patient to sit down on the saddle, check the secure fixation of the saddle as follows:



Figure 6-6: Tightening the clamping lever

DANGER

With the ergometer standing firmly, check that the saddle is securely clamped by trying to push it downwards from above. Adjust the clamping force of the clamping lever if necessary.



6.3.3 Saddle Adjustment with Gas Pressure Spring

For adjustment of the saddle height, pull the lever of the gas pressure spring upward as shown in figure 6-7. The saddle moves up automatically.

To lower the saddle, also pull the lever of the gas pressure spring upward. Push the saddle downward until it is at the correct height.

NOTICE

The gas pressure spring must be relieved for adjustment of the saddle height. No patient is allowed on the saddle while the height is being adjusted.



Figure 6-7: Saddle adjustment with gas pressure spring

7 Control Terminal M

7.1 Turning the System On

You turn on the ergometer by pressing the power switch. The ergometer runs a self-test. Subsequently, the start screen displays.



Figure 7 – 1:

NOTICE

- Instruct the patient not to pedal while the ergometer is being turned on and during the self-test.
- Apply the blood pressure cuff to the patient AFTER the ergometer has been turned on and the self-test completed.

Control terminal M is entirely operated by remote control (e.g., from an ECG recorder or a PC).

 With this key you initiate a blood pressure measurement. Pressing the key a second time during a measurement will stop the measurement.



Figure 7 – 2: Start screen

7.2 Operating Mode with Control Terminal M

Ergometers with control terminal M support the following operating mode:

PC Mode

An external device (e.g. an ECG recorder, a PC-based ECG system) controls the ergometer – no intervention at all is required at the ergometer.

When the ergometer is switched on, the display shows the start screen – the ergometer is waiting for commands from the external ECG unit.



Figure 7-3: Start screen

As soon as the ergometer receives commands from the controlling ECG unit or PC, the exercise test will start and the corresponding values will be displayed.

The exercise test can only be terminated with the corresponding command from the controlling ECG unit.

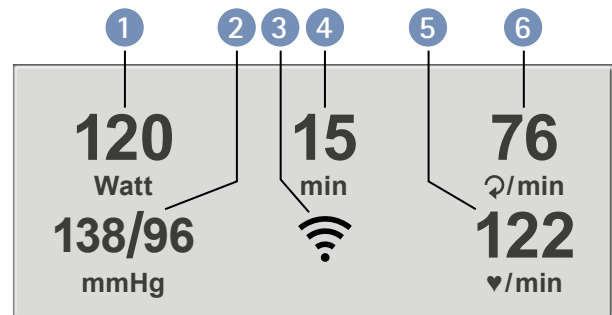

Figure 7-4: Exercise test screen 1

- ① current load (watts)
- ② most recent BP value (systolic/diastolic) or cuff pressure during inflation and bar graph indicating microphone signal strength (see below)
- ③ icon indicating wireless connection (Bluetooth or Wi-Fi)
- ④ duration of exercise test (min)
- ⑤ heart rate at the time of the BP measurement (BPM)
- ⑥ pedal speed (RPM)

NOTICE



During an exercise test, the saddle height can be adjusted with  and .



Figure 7-5: Exercise test screen 2

8 Control Terminal P

8.1 Turning the System On

You turn on the ergometer by pressing the power switch (toggle switch [I/O]).

The ergometer runs a self-test. Subsequently, the main menu displays.

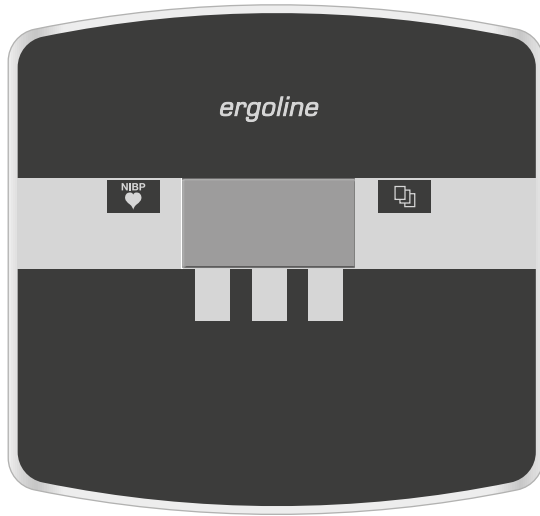





Figure 8-1:

NOTICE

- Instruct the patient not to pedal while the ergometer is being turned on and during the self-test.
- Apply the blood pressure cuff to the patient AFTER the ergometer has been turned on and the self-test completed.
- The device can be configured to default to one of the operating modes.
If this option is selected, the start screen of the selected operating mode (e.g., Ergometry) will be displayed instead of the main menu.
With the  key, you can display the main menu.

The ergometer software is controlled with 5 keys:

 With this key you display the main menu or return to the previous menu level.

 With this key you initiate a blood pressure measurement. A measurement in progress can be aborted with the same key.

 The functions of these three softkeys change with the displayed menu – the key label describing the function is shown on the display.

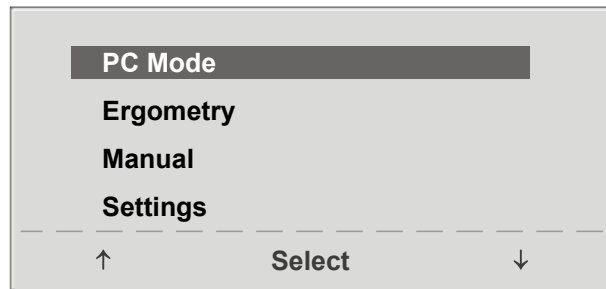

Figure 8-2: Main menu

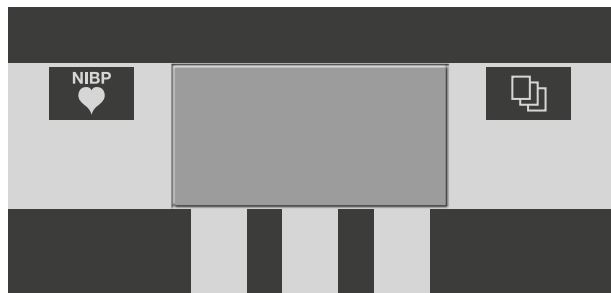

Figure 8-3:

8.2 Operating Modes with Control Terminal P

Ergometers with control terminal P support the following operating modes:

PC Mode

An external device (e.g., an ECG recorder, a PC-based ECG system) controls the ergometer – no intervention at all is required at the ergometer.

Ergometry

The ergometer runs an automatic exercise test – some of the corresponding test protocols are user-configurable and stored in the system.

(see chapter 8.2.4 "Settings with Control Terminal P" on page 41)

Manual

The ergometer is controlled manually, i.e., the user performs all load changes via the keypad.

Settings

Used to configure the ergometer.

8.2.1 PC Mode

Use the softkeys on the right and left (↑ ↓) to position the bar cursor on **PC Mode** and confirm the selection with **Select**.

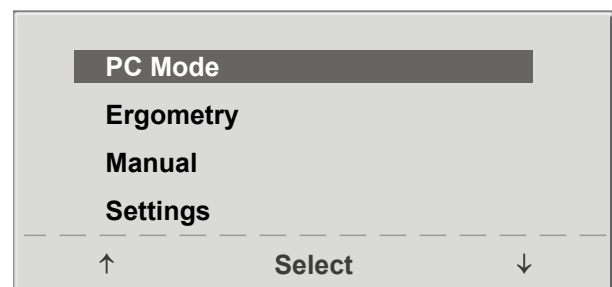

Figure 8-4: Main menu

The start screen will be displayed – the ergometer is waiting for commands from the external ECG unit.

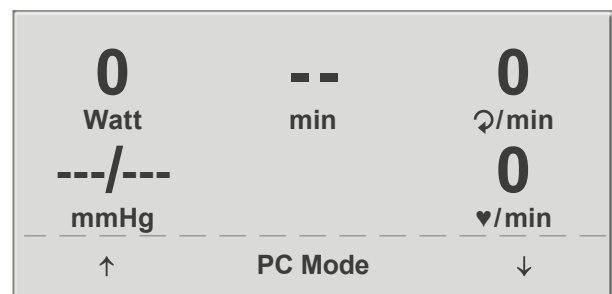

Figure 8-5: Start screen

As soon as the ergometer receives commands from the controlling ECG unit or PC, the exercise test will start and the corresponding values will be displayed.

The exercise test can only be terminated with the corresponding command from the controlling ECG unit.

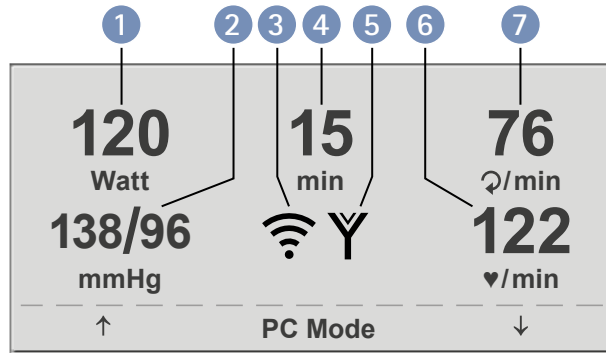

Figure 8-6: Exercise test screen 1

- ① current load (watts)
- ② most recent BP value (systolic/diastolic) or cuff pressure during inflation and bar graph indicating microphone signal strength (see below)
- ③ icon indicating wireless connection (Bluetooth or WLAN)
- ④ duration of exercise test (min)
- ⑤ heart rate measurement with the ergoline digital chest strap
- ⑥ heart rate at the time of the BP measurement (BPM)
- ⑦ pedal speed (RPM)

NOTICE



- All functions are locked while the ergometer is operating in PC mode, except for the saddle height adjustment and the blood pressure key.
- To reactivate the saddle height adjustment function, press  and the arrow keys will be displayed again.
- Additional blood pressure measurements can be initiated with .



Figure 8-7: Exercise test screen 2

8.2.2 Ergometry

Use the softkeys on the right and left (↑ ↓) to position the bar cursor on **Ergometry** and confirm the selection with **Select**.

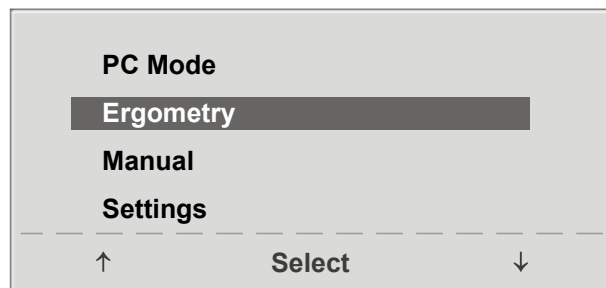

Figure 8-8: Main menu

The stored test protocols available for selection will be displayed. There are five fixed protocols (protocols 1 to 5, (see chapter 13.5 "Exercise Test Protocols" on page 89), whereas protocols 6 to 15 are user-configurable.

The protocol menu provides an overview of the test phases.

Example: **50 W/2 min/25 W**

means: Basic load of 50 W

Stage time of 2 min

Load stage of 25 W

Use the softkeys on the right and left (↑ ↓) to position the bar cursor on one of the protocols and confirm the selection with **Select**.

The exercise test is started with the **Start** key, a blood pressure measurement at rest may precede the test (depending on the selected exercise test protocol).

When the basic load appears on the display (after approx. 15 seconds or upon termination of the blood pressure measurement) and the patient's RPM indicator blinks, the patient should start pedaling.

The internal protocol will now control the entire exercise test – the display always indicates the current values.

With the +5 W and –5 W keys, the current load can be changed any time (in increments of +/-1 W up to +/-25 W, as configured).

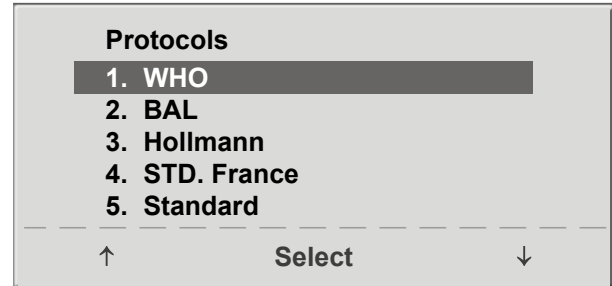

Figure 8-9: Selecting an exercise test protocol



Figure 8-10: Initial exercise test screen

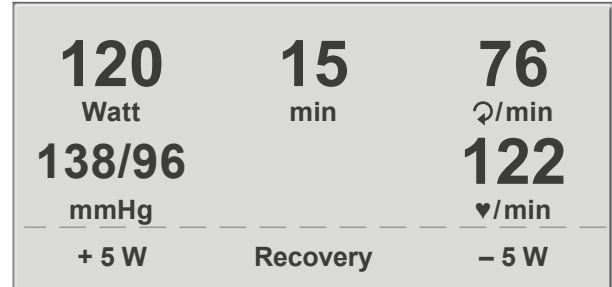

Figure 8-11: Display during the exercise test

NOTICE

The saddle height can be adjusted during an exercise test.

Terminating an Exercise Test

The exercise phase can be terminated manually at any time with the **Recovery** key.

The load will immediately be reduced to 25 watts, but a higher or lower value can be selected manually.

It is recommended that the patient continue to pedal in the recovery phase.

The **End** key in the middle will terminate the test.

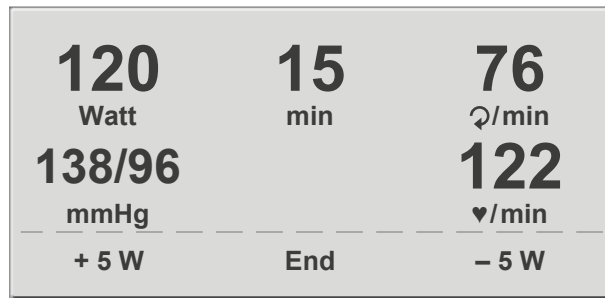

Figure 8-12: Recovery phase

8.2.3 Manual

Use the softkeys on the right and left (↑ ↓) to position the bar cursor on **Manual** and confirm the selection with **Select**.

In this operating mode the user controls the entire exercise test by selecting the loads, stage times and by initiating blood pressure measurements.

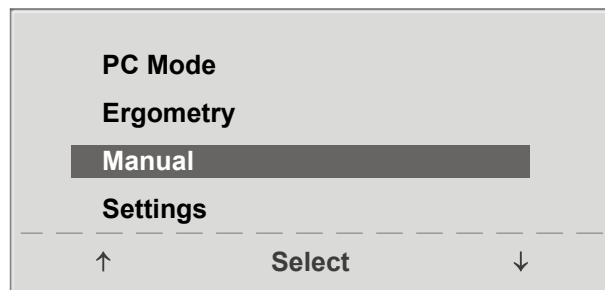

Figure 8-13: Main menu

The exercise test is started with the **Start** key, afterwards the load can be set and changed with the +5 W and -5 W keys (in increments of +/-1 W up to +/-25 W, as configured).

Blood pressure measurements can be initiated with .



Figure 8-14: Initial screen of a manual exercise test

Terminating the Manual Mode

The exercise test can be terminated manually at any time with the **End** key located in the middle.

The load will immediately drop to 0 watt.

There is no recovery phase in the manual mode.

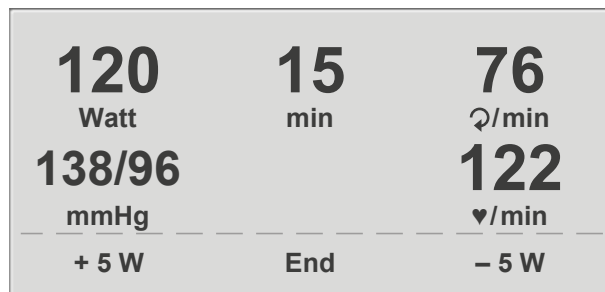

Figure 8-15: Display during the exercise test

8.2.4 Settings with Control Terminal P

Some of the device settings are configurable to meet specific requirements. The settings will be saved and remain stored even when the ergometer is switched off.

Use the softkeys on the right and left (↑ ↓) to position the bar cursor on **Settings** and confirm the selection with **Select**.

The configuration menu displays.

When all changes have been made, you can exit the configuration menu with the  key.

Use the softkeys on the right and left (↑ ↓) to position the bar cursor on the parameter to change and confirm the selection with **Select**.

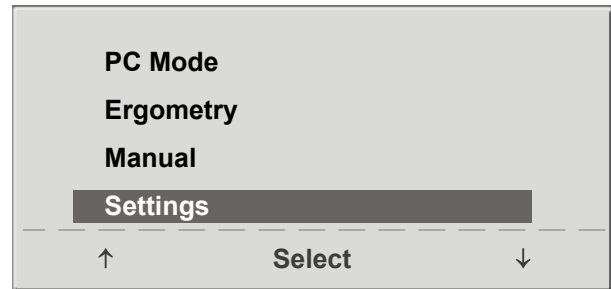

Figure 8-16: Main menu

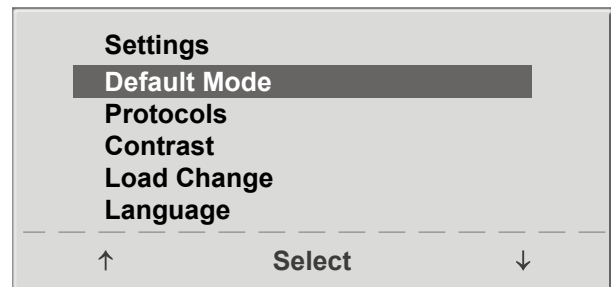

Figure 8-17: Configuration menu 1

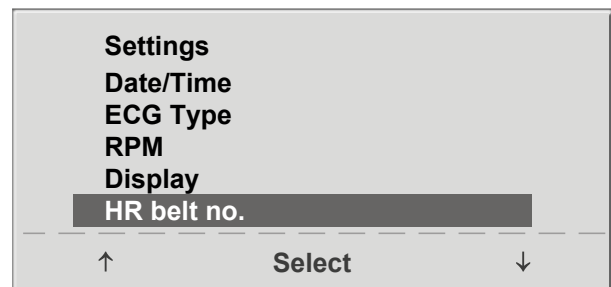

Figure 8-18: Configuration menu 2

Default Mode

In this menu you choose the default mode activated when the ergometer is turned on. When first turned on after delivery, the ergometer will display this menu.

Use the softkeys on the right and left (↑ ↓) to position the bar cursor on your preferred default mode and save the selection with **Select**.

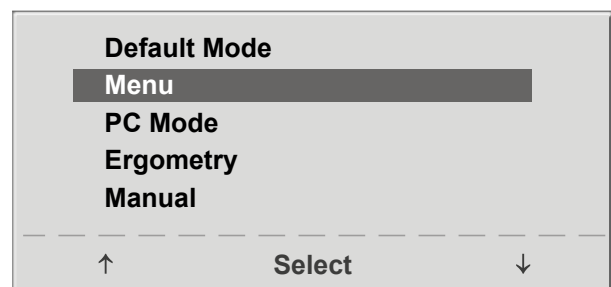

Figure 8-19: Selecting the default mode

Protocols

Protocols 6 to 15 are user-configurable (protocols 1 to 5 are fixed, see chapter 13.5 "Exercise Test Protocols" on page 89 for protocol parameter details). Default values can be entered for the following parameters:

- protocol type (Step/Ramp)
- basic load
- stage time
- load stage (load increase with each stage)

Use the softkeys on the right and left (↑ ↓) to position the bar cursor on the protocol to change (No. 6 to 15) and confirm the selection with **Select**.

Use the softkeys (↑ ↓) to select the parameter to edit.

At **Select**, for example, you can choose the protocol type:

- Step (load increase in steps) or
- Ramp (continuous load increase).

Press **Select** to save the selected protocol type.

To cancel the selection, press the  key.

All other parameters are edited in the same way.

Using the arrow keys (↑ ↓), select a parameter and confirm the selection with **Select**: the corresponding value is high-lighted and can be changed with the arrow keys (↑ ↓).

Pressing **Select** will save the new value.

You exit the configuration with .

Contrast

The display contrast is adjustable in the range from 0 to 100%.

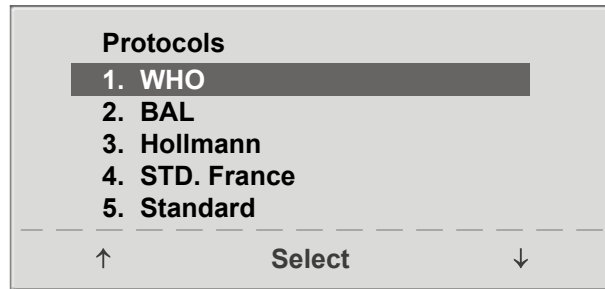

Figure 8-20: Selecting the exercise test protocol to configure

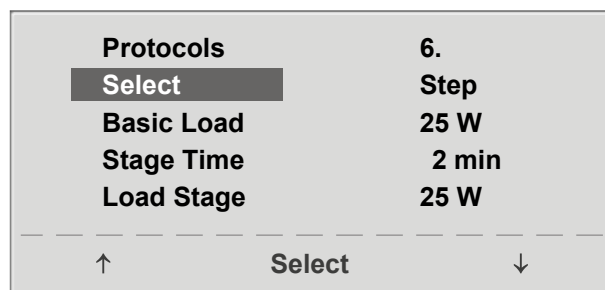

Figure 8-21: Selecting the parameter to edit

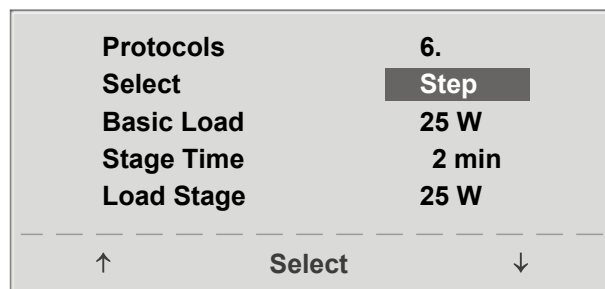

Figure 8-22: Editing the parameter value

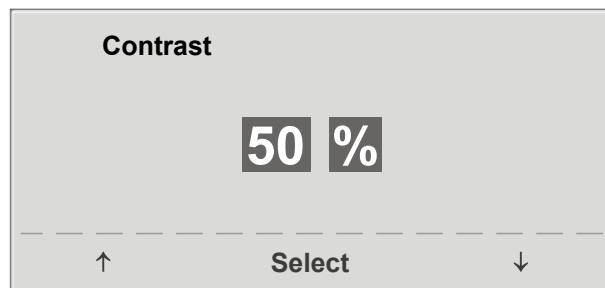

Figure 8-23: Adjusting the display contrast

Load Change

Here you determine the increments for each load change. Depending on your choice, each key press will change the load by +/- 1, 5, 10 or 25 watts.

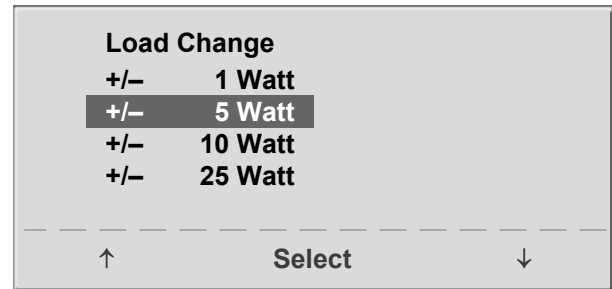

Figure 8–24: Selecting the increment for manual load changes

Language

The texts can be displayed in different languages.

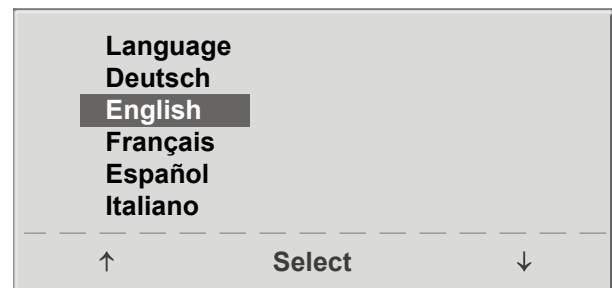

Figure 8–25: Language menu

Beep

The audio signal emitted during blood pressure measurements can be turned on and off.

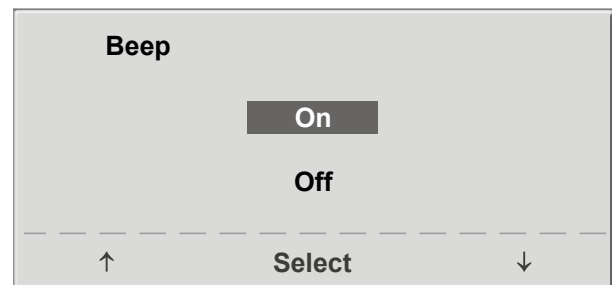

Figure 8–26: Beep during BP measurements

Software Version

Select this option to view the installed software version.

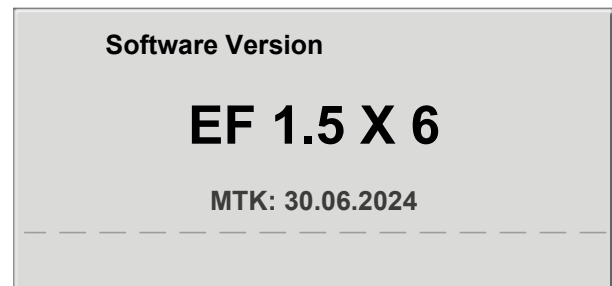



Figure 8–27: Display of the installed software version

Date/Time

To begin with, you select **Date** and confirm the selection. Then the highlighted value can be edited with the ↑ ↓ keys and saved with **Select**.

The time is adjusted in the same way. You exit the configuration with .

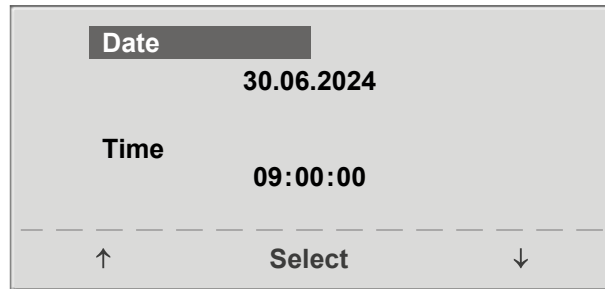

Figure 8–28: Setting the date

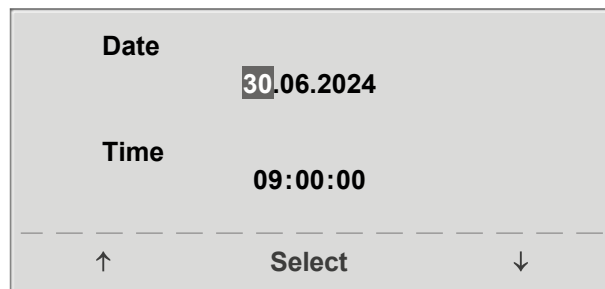

Figure 8–29: Setting the day

ECG Type

The selected ECG Type determines the communication method with the ECG recorder, PC-based ECG system, etc.

To prevent an accidental change of this setting, the menu is protected with a password. Using the arrow keys, enter 003 and confirm the entry with **Select**.

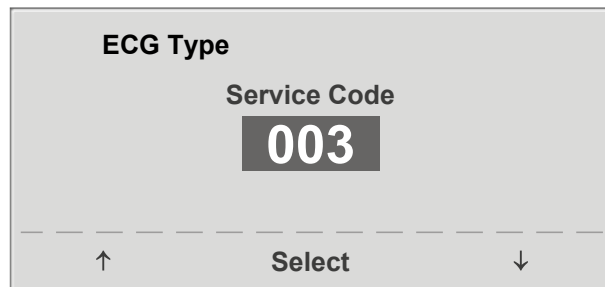

Figure 8–30: Entering the ECG Type password

All ergometers support the following communication modes:

- **Analog with pulse**
Remote start mode; before advancing to the next load level, the ergometer generates a control pulse and sends the corresponding data via the interface.
- **Analog/Digital**
An analog voltage controls the load – blood pressure measurements can be initiated with digital commands.
- **Digital (default)**
The communication with the ergometer is entirely controlled with digital commands.
- **Analog IN-OUT**
The entire communication (load control and BP measurements) is controlled with analog signals. No digital data will be sent.

Select the communication mode and confirm with **Select**.

NOTICE

- *The ECG Type needs to be selected only when the ergometer is connected to an ECG unit. This configuration setting is part of the installation procedure.*
- *The "Analog/Digital" and "Digital" communication is only possible when PC Mode is selected from the main menu or when this is the default mode.*

RPM

Here you determine the RPM limits. When these limits are exceeded, the LEDs for high or low speed (RPM) will illuminate.

Select the value to change (Min. or Max.) and confirm with **Select**.

Using the arrow keys, change the value and save the new value with **Select**.

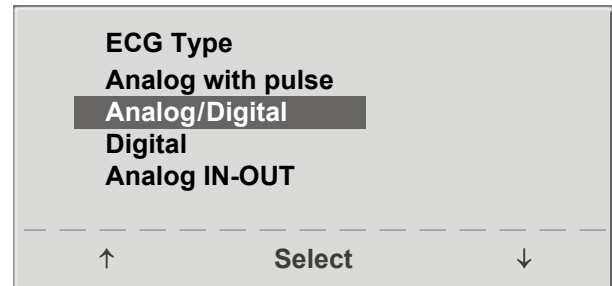

Figure 8–31: Selecting the ergometer communication mode

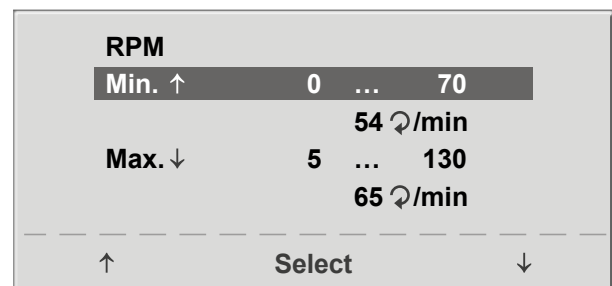

Figure 8–32: Setting the RPM limit values

NOTICE

The limits selected in this menu only apply to the load range between 6 and 150 watts. At higher loads the RPM limits automatically adapt to the respective load ranges:

Load (watts)	Green RPM range (1/min)
6 – 150	54 – 64 (adjustable)
151 – 250	58 – 65
251 – 350	68 – 75
351 – 450	78 – 85
451 – 550	88 – 95
551 – 650	98 – 105
651 – 750	108 – 115
751 – 850	118 – 125
851 – 950	> 125
951 – 999	> 130

Pulse Display

The pulse readout on the display can be turned off.

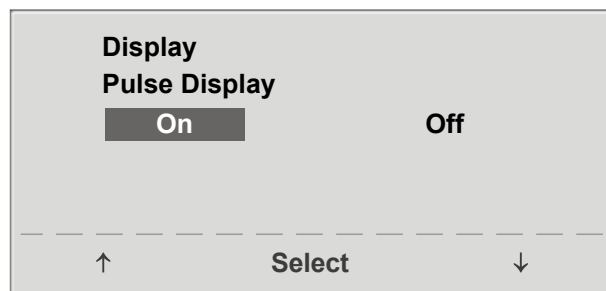

Figure 8–33: Setting the pulse readout

HR Belt Number

If the test subject wears a chest strap to measure the heart rate during the training, the corresponding chest strap number must be entered here. You will find the number on the back of the housing. It is the unique identifier for this particular strap.

With keys ↑ ↓, you toggle between the menu screens.



Figure 8–34: Setting the HR belt no., screen 1

When the HR belt option has been selected (see figure 8–34), you can set the first digit of the number of up to 8 digits by pressing key ↓. The desired numeral is selected with the arrow keys and the selected numeral is saved with the Select key. Repeat these steps for each numeral until the complete number has been entered.



Figure 8–35: Setting the HR belt no., screen 2

9 Control Terminal T

9.1 Turning the System On

You turn on the ergometer by pressing the power switch (toggle switch [I/O]).

NOTICE

- *Instruct the patient not to pedal while the ergometer is being turned on and during the self-test.*
- *Apply the blood pressure cuff to the patient AFTER the ergometer has been turned on and the self-test completed.*
- *The device can be configured to default to one of the operating modes. If this option is selected, the start screen of the selected operating mode (e.g., Ergometry) will be displayed instead of the main menu.*

The ergometer runs a self-test. Subsequently, the main menu displays.

The ergometer software is controlled from the touch panel.



Figure 9-1:

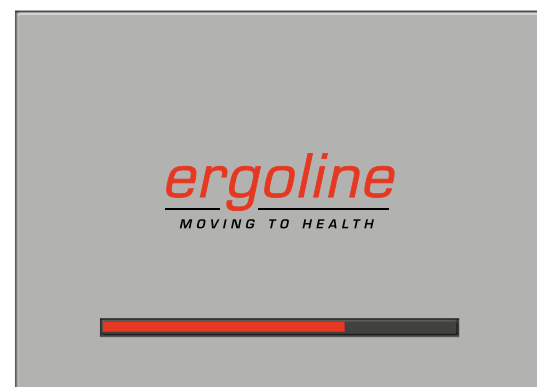

Figure 9-2: Self-test screen

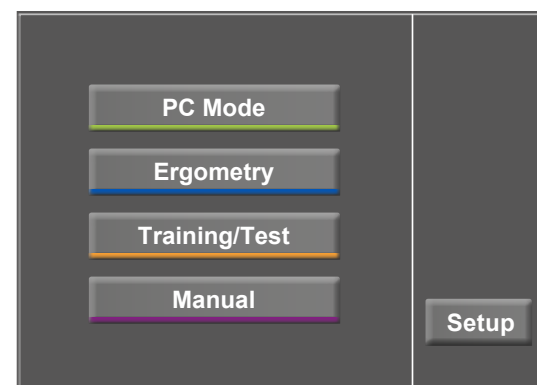

Figure 9-3: Main menu

9.2 Operating Modes with Control Terminal T

Ergometers with control terminal T support the following operating modes:

PC Mode

An external device (e.g., an ECG recorder, a PC-based ECG system) controls the ergometer – no intervention at all is required at the ergometer.

Ergometry

The ergometer automatically completes the selected exercise test – the available protocols (5 preconfigured, editable protocols and 5 user-configurable protocols) are saved in the ergometer (see section “Editing Settings” on page 51).

Training/Test

Ten user-configurable training/test protocols are available (see chapter 9.2.3 “Training/Test” on page 54).

Manual

The ergometer is controlled manually, i.e., the user performs all load changes via the display.

Setup

Used to configure the ergometer. The button disappears within 2 minutes after the ergometer was switched on. This interval can be modified in the Service menu.

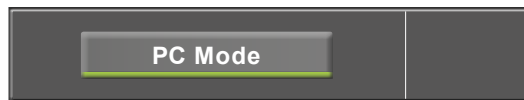

Figure 9-4: PC mode

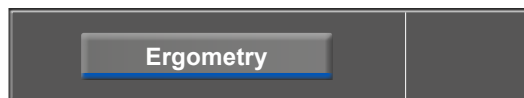

Figure 9-5: Ergometry mode

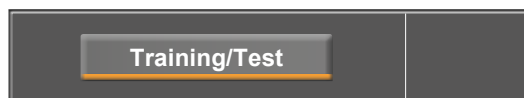

Figure 9-6: Training/Test mode

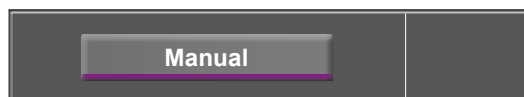

Figure 9-7: Manual mode



Figure 9-8: Setup mode

9.2.1 PC Mode

When the [PC Mode] key has been pressed, the screen appears as shown at right. The ergometer is waiting for commands from the external ECG unit.

As soon as the ergometer receives commands from the controlling ECG unit or PC, the exercise test will start and the corresponding values will be displayed.

The screen displays the status of the wireless connection (Bluetooth, WLAN), the heart rate (BPM), the blood pressure values (mmHg), the oxygen saturation in percent (%), the duration of the exercise test (min:ss), the pedal speed (RPM), and the current load (W).

The exercise test can only be terminated with the corresponding command from the controlling ECG unit.

A blood pressure measurement can be initiated with the [RR] key. Pressing the [RR] key a second time during a measurement will stop the measurement.

To display the perfusion index (PI), press the center of the field 4. The display automatically switches back to the main SpO₂ view.

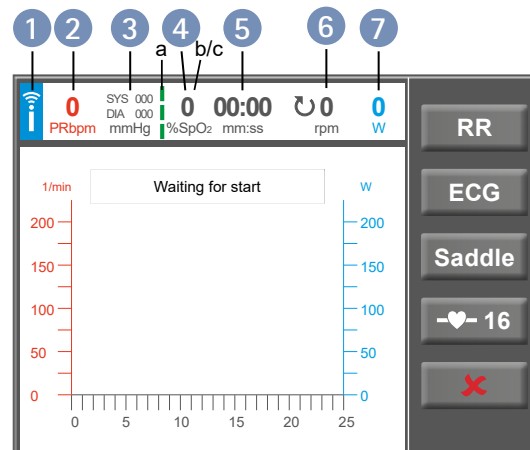

Figure 9-9: PC mode screen

- 1 icon indicating wireless connection (Bluetooth or WLAN)
- 2 heart rate HR of ECG / chest strap (bpm / ¹/min)
pulse rate PR of SpO₂ / NIBP (bpm / ¹/min)
- 3 most recent BP value (systolic/diastolic) or cuff pressure during inflation
- 4 SpO₂
 - 4a signal quality
 - 1 bar: 1 – 30%
 - 2 bars: 31 – 60%
 - 3 bars: 61 – 100%
 - 4b oxygen saturation SpO₂ (% SpO₂)
 - 4c perfusion index (PI) (%)
 - pulsation strength of blood circulation, indicator of signal quality if > 1%
- 5 duration of exercise test (min:ss)
- 6 pedal speed (RPM)
- 7 current load (watts)

ECG Mode

The display changes when the [ECG] key is pressed. The acquired electrical signals will be displayed. The amplitude (gain) can be adjusted with the arrow keys [▲] and [▼].

The pump for the suction electrode system can be switched on and off with the [I/O] key.

The vacuum intensity can be changed between low, medium and high by touching the [I/O] key.

To switch off the pump, the displayed key [low], [middle] or [high] must be pressed for about 3 seconds.

All inputs are confirmed with the [✓] key.

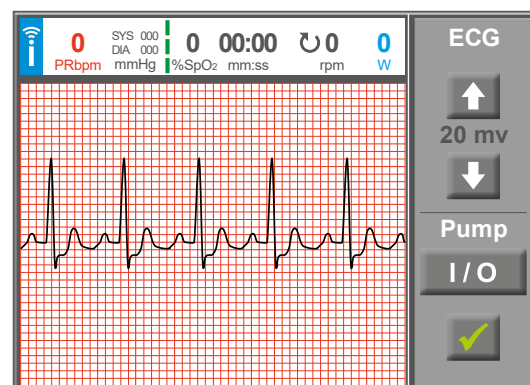

Figure 9-10: ECG screen

Heart Rate Measurement

If equipped with the appropriate option, the ergometer display shows the [-♥-] key. The number next to the icon is the number of the assigned heart rate belt. Pressing this key displays further information (see figure 9 – 12).

! WARNING

Patient Hazard

Heart rate measuring systems may be inaccurate. There is a risk of wrong or missing heart rate data leading to inadequate therapy and/or over-exertion.

After tapping the key with the number [16], another heart rate belt can be assigned.

By pressing a number key on the keypad, the belt with the corresponding ID will be assigned. For further information on assigning heart rate belts, see chapter 9.2.6 "Setup", section "HR Belt Number" on page 75.

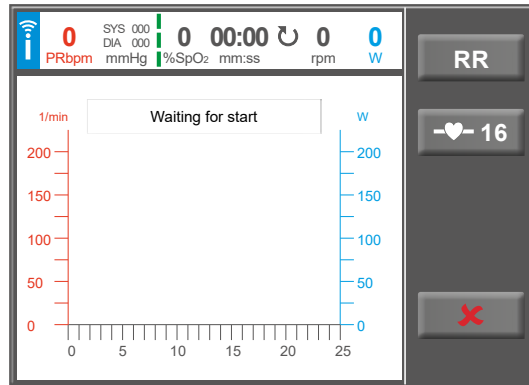

Figure 9 – 11: PC mode screen with assigned heart rate belt

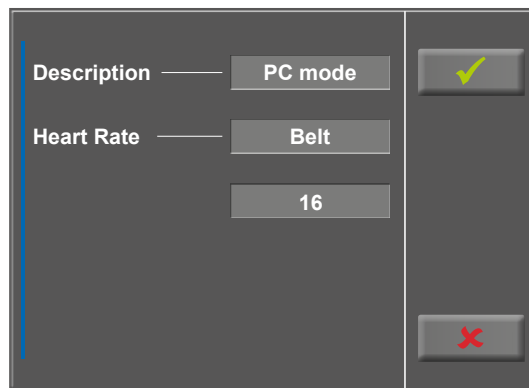

Figure 9 – 12: Information on the assigned HR belt

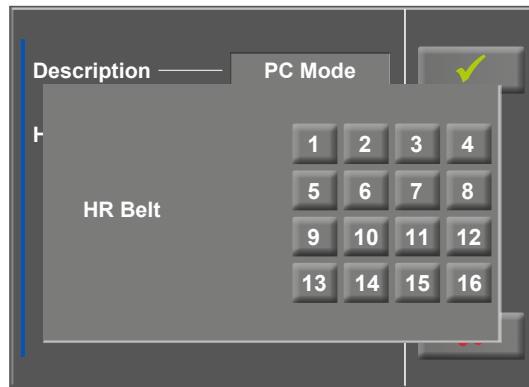

Figure 9 – 13: Selecting the heart rate belt

9.2.2 Ergometry

After pressing the [Ergometry] key in the main menu, you will see the different exercise test protocols (5 preconfigured, editable and 5 user-configurable protocols) to choose from.

All exercise test protocols (including the 5 preconfigured protocols) are editable.

NOTICE

Changes to one of the 5 preconfigured protocols cannot be saved. The changes remain valid only until the ergometer is switched off.

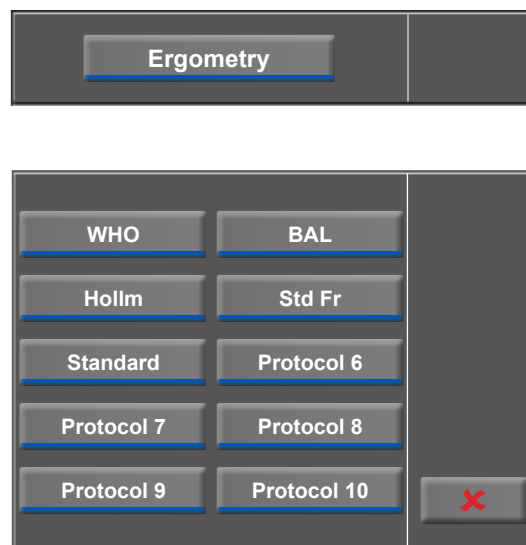

Figure 9 – 14: Ergometry menu

Editing Settings

When you touch a protocol, the available parameters will be displayed.

All protocols can be edited during operation (except for the PC mode).

User-configured, custom protocols must be saved via [Setup] in the main menu (see chapter 9.2.6 "Setup", section "Protocols" on page) 72.

Pressing key [↓2.] displays a detailed list of the exercise test parameters, such as:

Step Type: Basic Load: 30 W
 Stage Time: 2 min
 Stage Rate: 25 W
 Recovery Time: 2 min
 Recovery Load: 25 W

Ramp Type: Basic Load: 30 W
 Slope: 50 W/min
 Recovery Time: 2 min.
 Recovery Load: 25 W

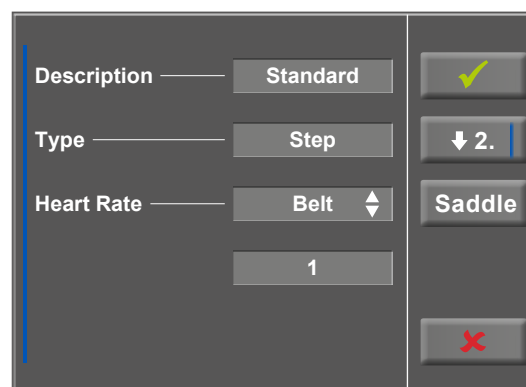

Figure 9 – 15: Ergometry – editing protocol parameters, screen 1

NOTICE

It is not possible to edit the parameters of the "Ramp" program type.

9 Control Terminal T

With the [Edit] key, you can modify each protocol parameter. The new inputs overwrite the existing values.



Figure 9–16: Ergometry – editing protocol parameters, screen 2

In the configuration menu, the following parameters can be edited:

- the basic load (from 6 to 100 W),
- the stage time (from 1 to 30 min),
- the stage rate (increment, from 1 to 400 W).

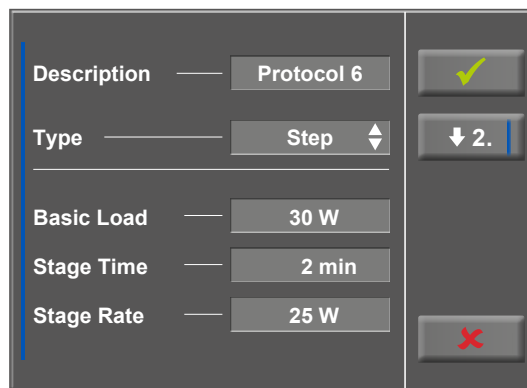

Figure 9–17: Ergometry – editing protocol parameters, screen 3

With the [↓2.] key, you proceed to the next menu level where you can edit these parameters:

- the recovery load (from 6 to 100 W) and
- the recovery time (from 1 to 30 min).

With the [↑1.] key, you return to the previous screen.

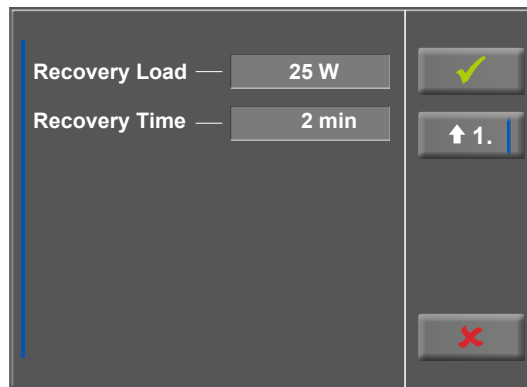

Figure 9–18: Exercise test protocol, basic load, screen 1

Touch a light gray field, e.g., at Basic Load: a submenu with input field and numeric keypad opens. You can enter values directly via the numeric keypad.

Confirm your inputs with the [✓] key. To cancel the input, press the [✕] key.

The other parameters can be edited in the same way, they will overwrite the current values.

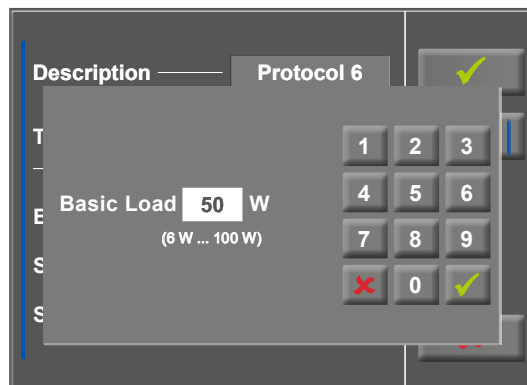

Figure 9–19: Exercise test protocol, basic load, screen 2

When you touch the [✓] key again after confirming, the display will change. Touching the [Start] key on the display will initiate the training session. The session is entirely controlled by the protocol. The display indicates the current values.

When you press the [const.] key, the current load will be maintained for the rest of the session.

You change the load with the [+5 W] and [-5 W] keys. The Watt level can be individually adjusted (see chapter 9.2.6 "Setup", section "Load Change" on page 70).

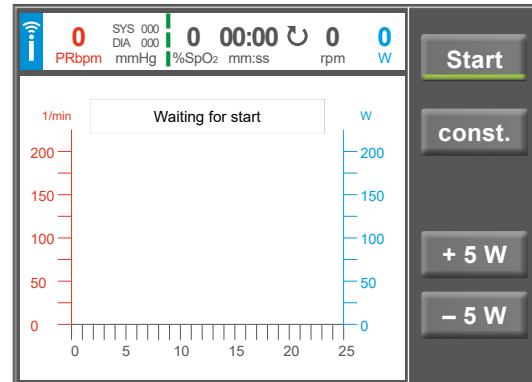

Figure 9–20: Starting an exercise test

Terminating the Program

Once the full protocol has been completed, it terminates automatically.

The protocol can be terminated manually at any time with [Stop]. First, you enter the recovery phase.

When you touch [Stop] again, the training will be terminated.

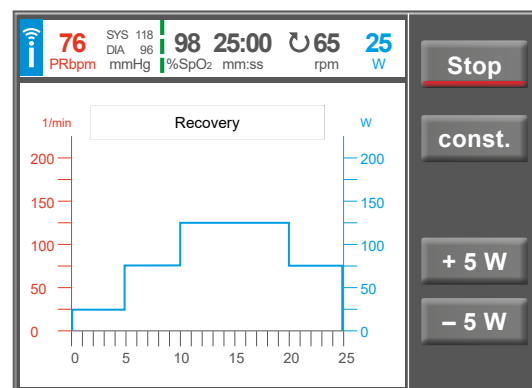

Figure 9–21: Terminating an exercise, screen 1

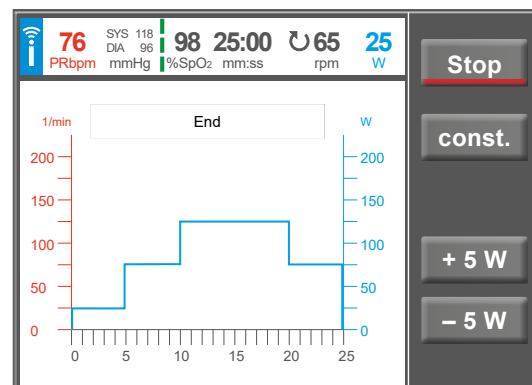

Figure 9–22: Terminating an exercise, screen 2

9.2.3 Training/Test

Training sessions and performance tests with the ergometer can only be carried out if the protocols are first created in the main menu under Setup (see chapter 9.2.6 "Setup" on page 69).

Once created, these training/test protocols can be called up with Training/Test in the main menu and further adapted to the individual patient.

All displayed protocols are editable before the protocol is started.

Definitions:

A training session (pulse, constant, interval, interval HR) is defined by the phases

- Warmup
- Training
- Recovery.

A test (ramp test, PWC) is defined by the phases

- Warmup
- Test
- Recovery.

The defined protocol steps depend on the selected protocol type (see table on page 55).

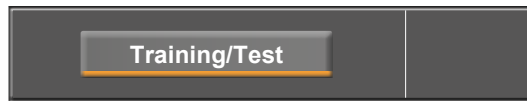

NOTICE

The test outcome and the resulting values are to be considered only as proposals. The results must be verified and evaluated by a qualified physician to obtain a diagnosis and set up a therapy plan.

Available protocol steps/Description of the protocol step/Used in the following protocol type

Protocol step	Definition	Protocol type
Warmup Load	Load in the warm-up phase	Pulse, Constant, Interval, Interval HR, PWC
Warmup Time	Duration of the warm-up phase	Pulse, Constant, Interval, Interval HR, PWC
Increase	Period of time during which the recovery load increases to the training load	Pulse, Constant, Interval, Interval HR
Basic Load	Load level at the beginning of the ramp test	Ramp test
Training time	Duration of the training phase	Pulse, Constant, Interval, Interval HR, PWC, Countdown
Heart Rate	Individual training heart rate	Pulse, Interval HR
HR Limit 1	Heart rate limit 1 to calculate the relative load in watts per kg body weight	PWC 1
HR Limit 2	Heart rate limit 2 to calculate the relative load in watts per kg body weight	PWC 2
HR Limit 3	Heart rate limit 3 to calculate the relative load in watts per kg body weight	PWC 3
Training load max.	Maximum possible load during the training phase	Pulse
Training load	Load during the training phase	Constant, Countdown
Load Stage 1	Load in interval 1	Interval, Interval HR
Stage Time 1	Duration of interval 1	Interval, Interval HR
Load Stage 2	Load in interval 2	Interval, Interval HR
Stage Time 2	Duration of interval 2	Interval, Interval HR
Load Change	Load change between the defined stages	PWC
Stage Time	Duration of the repeating stages	PWC
Slope	Slope of the ramp in watts/min	Ramp test
Decrease	Period of time during which the training load decreases to the recovery load	Pulse, Constant, Interval, Interval HR
Recovery Load	Load during the recovery phase	Pulse, Constant, Interval, Interval HR, PWC, Ramp test
Recovery Time	Duration of recovery stage	Pulse, Constant, Interval, Interval HR, PWC, Ramp test
Weight	Patient weight	PWC

9 Control Terminal T

After pressing the [Training/Test] key in the main menu, you will see the defined Training/Test protocols.

You can choose from 20 different protocols:

- Pulse
- Constant
- Interval
- Interval HR
- Countdown
- Ramp test
- PWC Test 1
- PWC Test 2
- PWC Test 3

Select the desired protocol by pressing the appropriate key.

With the [Edit] key, you enter the first input level of the protocol.

At *Heart Rate* you can select the available sources of the heart rate signal.

Options are:

- HR belt (requires selection of the HR belt ID)
- ECG (suction system On/Off – if available)
- Polar

NOTICE

Make sure that the selected belt ID is the ID of the belt actually used on the patient.

Further editing options depend on the selected protocol type; they are described in detail for each test and training protocol below.

With the [Edit] key, you always enter the first input level of the protocol.

If a protocol type has more than one input levels, you return to the previous level **↓2.** and advance to the next level **↑2.** with the appropriate number key.

If you need to input characters (numbers or letters), an (alpha-) numeric keypad or a keyboard will be displayed.

Inputs are confirmed with the [✓] key.

The following sections describe each protocol type in detail.

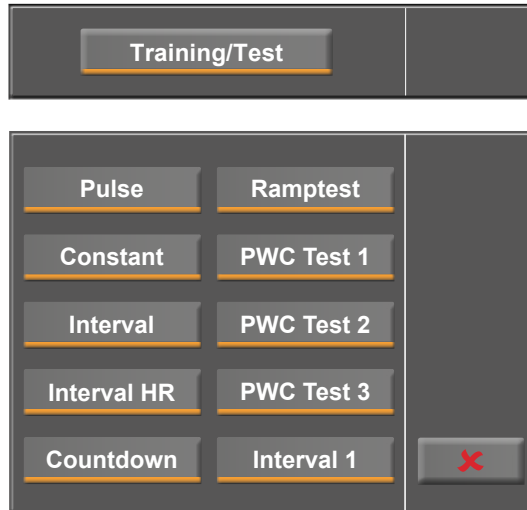

Figure 9-23: Selecting the training/test protocol



Figure 9-24: Training/test – editing protocol parameters

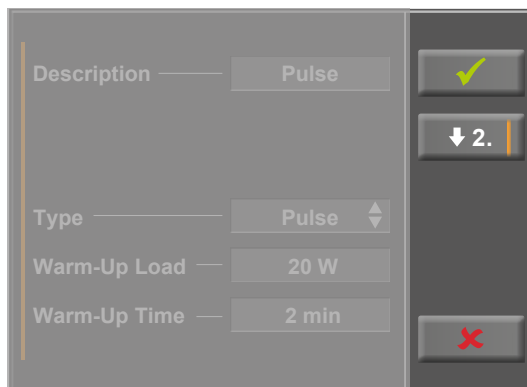

Figure 9-25: Changing the input level

Pulse

During a heart-rate controlled training session, the load increases gradually until the specified training heart rate is reached. If the patient's heart rate exceeds the training heart rate, the load will be reduced

The entered maximum training load should be determined individually for each patient.

The entered heart rate should be determined individually for each patient.

In Setup, further settings for regulation of the training parameters can be configured for the "Pulse" training (see also figure 9-79 on page 76).

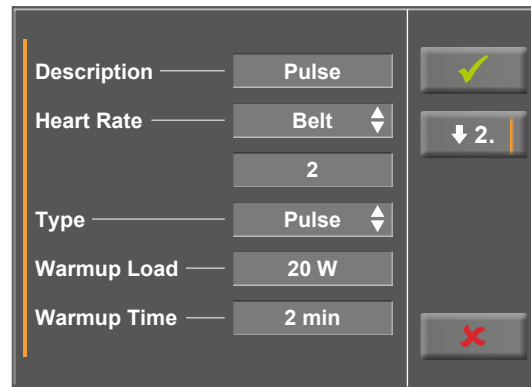

Figure 9-26: Protocol type "Pulse" - level 1

! WARNING

Patient Hazard

Heart rate measuring systems may be inaccurate. There is a risk of wrong or missing heart rate data leading to inadequate therapy and/or over-exertion.

! CAUTION

If the heart rate signal is lost during a pulse-controlled training or the displayed value is 0, the load will gradually be reduced to 0 watt.

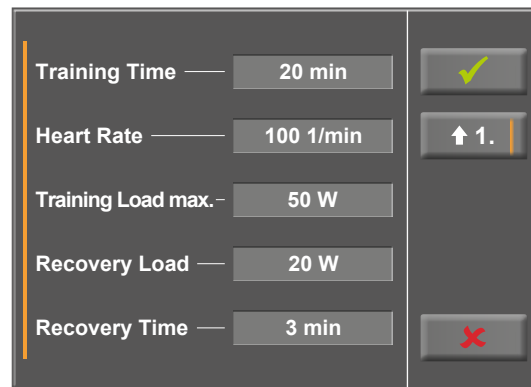

Figure 9-27: Protocol type "Pulse" - level 2

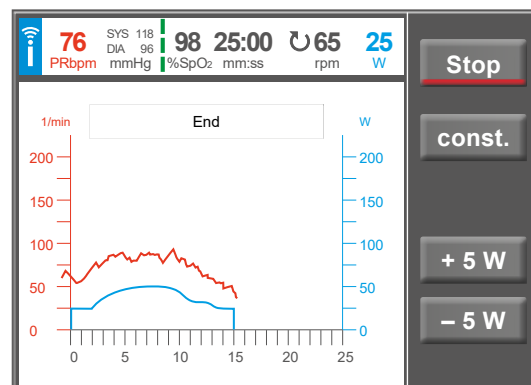

Figure 9-28: Example of a heart rate controlled training

Constant

In a constant load training, a training load is specified and maintained throughout the session.

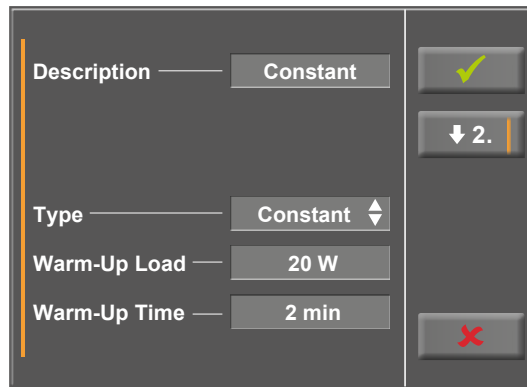

Figure 9–29: Protocol type "Constant" – level 1



Figure 9–30: Protocol type "Constant" – level 2

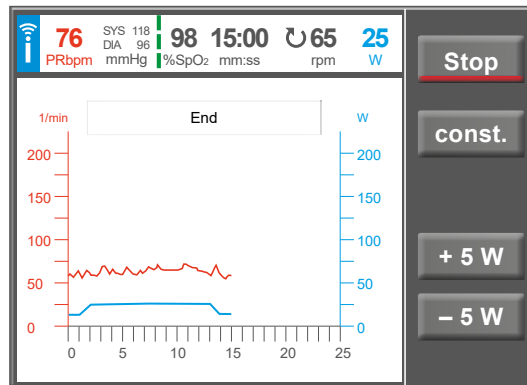

Figure 9–31: Example of a constant load training

Interval

An interval training alternates between the load levels of stages 1 and 2 at the end of each stage.

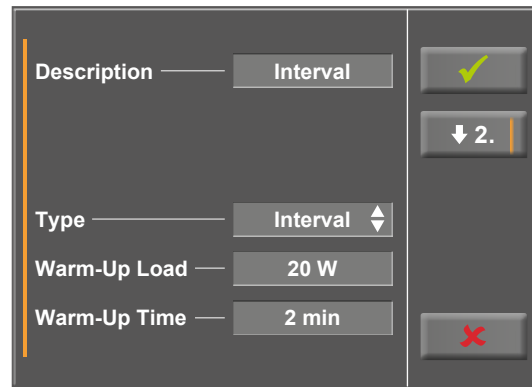

Figure 9–32: Protocol type "Interval" – level 1

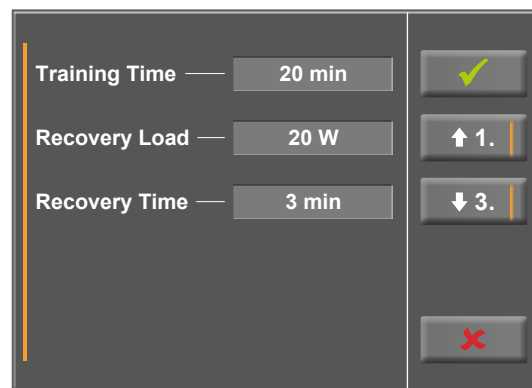

Figure 9–33: Protocol type "Interval" – level 2

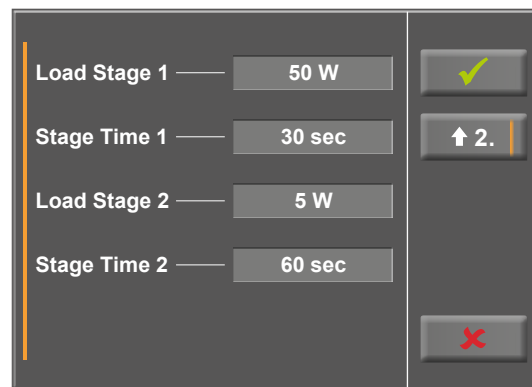

Figure 9–34: Protocol type "Interval" – level 3

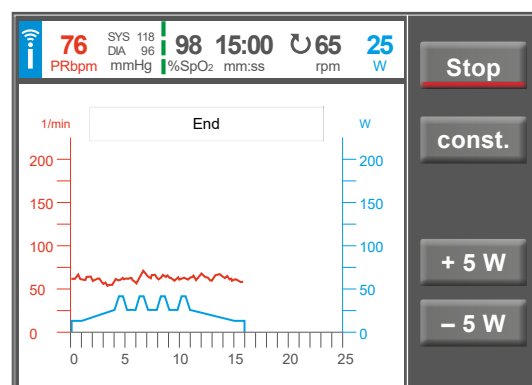

Figure 9–35: Example of an interval training

Interval HR

For HR-controlled interval training protocols it is possible to define an automatic adaptation of the load levels to take place during the training sessions.

The criteria for monitoring of the heart rate are a defined upper and a lower heart rate limit. The limit is the sum of the training heart rate (Trng. HR) and the "Threshold".

- Upper Limit = Trng. HR + Threshold
- Lower Limit = Trng. HR - Threshold

If the measured heart rate is permanently above the upper training heart rate limit at the falling edge of an interval for a certain period of time (parameter "Delay"), the load for the subsequent training interval will be reduced.

If the measured heart rate is permanently below the lower training heart rate limit at the falling edge of an interval for a certain period of time (parameter "Delay"), the load for the subsequent training interval will be increased. A load increase, however, is only possible when the load was reduced before, because the load specified for the training interval is always the maximum possible training load.

The entered heart rate should be determined individually for each patient.

(See also section "HR Monitoring" on page 78).

 **WARNING**

Patient Hazard

Heart rate measuring systems may be inaccurate. Incorrect and/or prohibited use and/or over-exercising may have serious or even fatal consequences. The training has to be stopped immediately if the test subject experiences symptoms like dizziness.

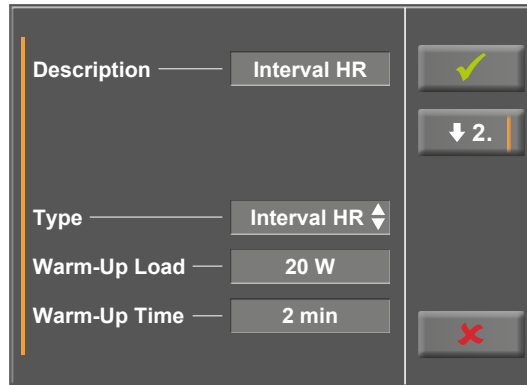

Figure 9 – 36: Protocol type "Interval HR" – level 1



Figure 9 – 37: Protocol type "Interval HR" – level 2



Figure 9 – 38: Protocol type "Interval HR" – level 3

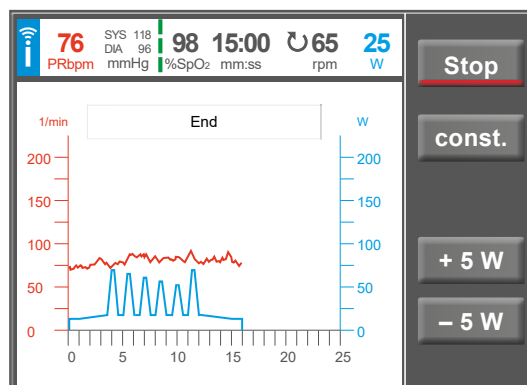

Figure 9 – 39: Example of an interval HR training

Countdown

The "Countdown" protocol is a constant load training with a decreasing timer. Training duration and load can be edited prior to the session. The training load can be adjusted manually also after the session was started.

The training stops automatically when the timer runs out.

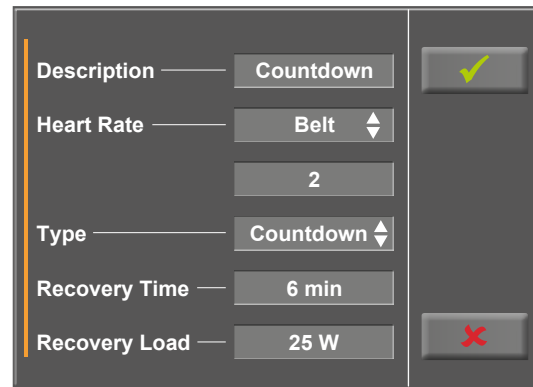

Figure 9–40: Protocol type "Countdown"

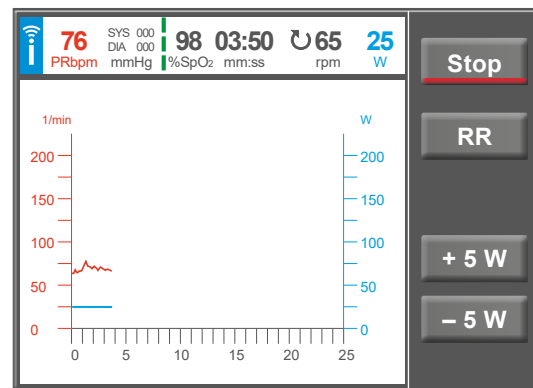

Figure 9–41: Example of a "Countdown" training

Ramp Test

In the ramp test, the load increases continuously (after definition of the increment) until the recovery phase is initiated manually.

NOTICE

The test outcome and the resulting values are to be considered only as proposals. The results must be verified and evaluated by a qualified physician to obtain a diagnosis and set up a therapy plan.



Figure 9 – 42: Protocol type "Ramp test" – level 1

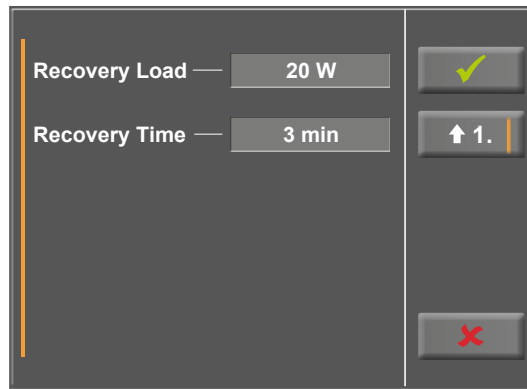

Figure 9 – 43: Protocol type "Ramp test" – level 2

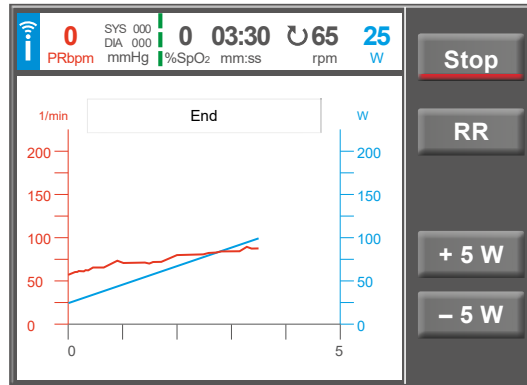

Figure 9 – 44: Example of a ramp test

PWC Test

The PWC test can only be performed with a continuous HR generator (HR belt, ECG, SpO₂).

Three PWC tests are available.

The specified parameters are presented in the table in chapter 13.6 on page 89.

In these tests, the load increases continuously step by step until a predefined heart rate is reached. The level in which the maximum heart rate is exceeded is maintained until the end of the load interval. Then, the recovery phase is started.

Subsequently, the relative performance is calculated in watts per kilogram body weight based on the defined heart rate limits in the protocol type.

To correctly calculate the relative performance, the patient's body weight [Weight] needs to be entered.

The relative performance can only be calculated when the PWC test is performed until the patient reaches the maximum defined heart rate limit.

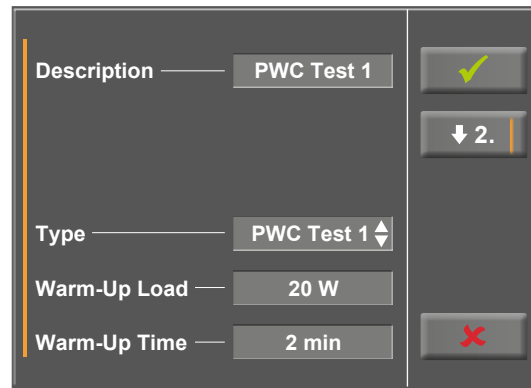

Figure 9-45: Protocol type "PWC Test" – level 1



Figure 9-46: Protocol type "PWC Test" – level 2



Figure 9-47: Protocol type "PWC Test" – level 3

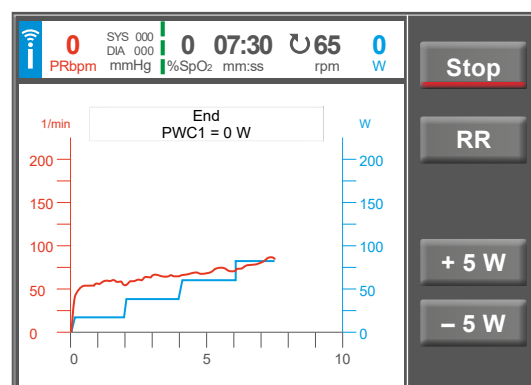

Figure 9-48: Example of a PWC test

9.2.4 Training with Chip Card

As an alternative to the training protocols saved in the ergometer, it is possible to load training protocols from a chip card.

The PC software "ergoline opticare basic" is used to write the training protocols to the chip card.

Upon completion of the training session, the ergometer saves the entire session (incl. load and heart rate waveforms) to the chip card – the data can be reviewed and analyzed at the PC later on.

You can choose between three different chip card modes:

1. Chipcard possible
2. Chipcard only
3. Only CPC + Memory

The preferred mode can be set in the Service menu.

"Chipcard possible" Mode

The *Manual* and *Countdown* operating modes are available with "Chipcard possible".

These operating modes are not available with "Chipcard only".

Session Start with Chip Card Training Protocols

Insert the training card with the stored protocol into the chip card reader (on the right side of the control terminal) – the golden chip on the training card faces down.

Select the "Training" mode and confirm with **Start**.



Figure 9 – 49: ergoline training chip card



Figure 9 – 50:

The ergometer switches to the chip card mode and reads the data stored on the card.

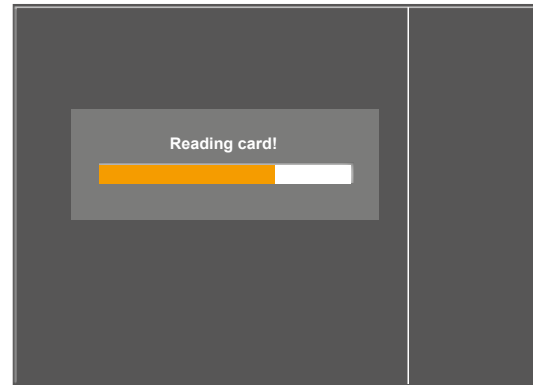

Figure 9–51: Reading the chip card data

Name and weight stored on the card are displayed first.

The actual weight can be entered via the numeric keypad.

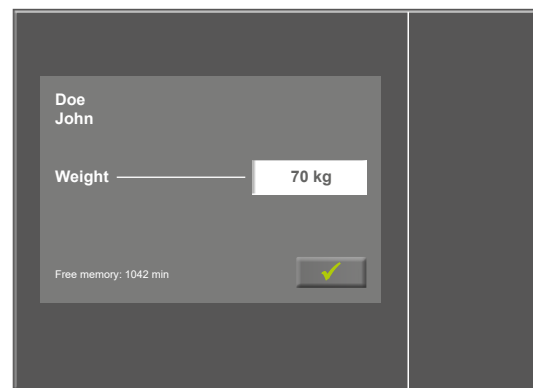

Figure 9–52: Entering the weight

After pressing the [✓] key, the training protocols stored on the chip card will be displayed.

Select the appropriate training protocol and confirm with **Start**.

The chip card training session proceeds in the same way as the training protocols stored in the ergometer.

NOTICE

It is NOT possible to edit the training protocols stored on the card but they can be reviewed.

Terminating the Training Session

On completion of the training session (automatic termination at the end of the programmed recovery phase or manual termination with the Stop key), the test subject can indicate how the exertion was perceived.

Ratings from "Very, very light" to "Very, very hard" can be selected with the arrow keys.

Inputs are confirmed with the [✓] key.



Figure 9–53: Entering the exertion rating

9 Control Terminal T

Subsequently the data of your training session are written to the chip card after which they are available for analysis with a special program (opticare basic).

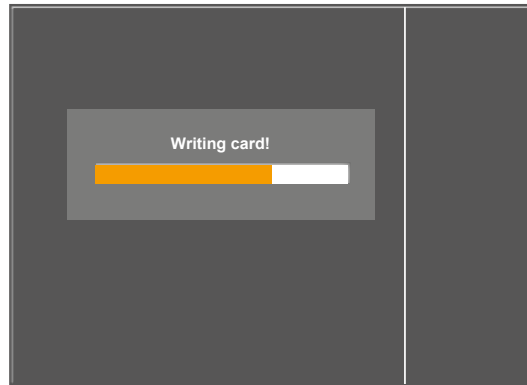

Figure 9–54: Writing to the chip card

When the data has been written to the chip card, the user is prompted to remove it.

Remove the chip card from the control terminal.

After removal of the card, the main menu of the ergometer is displayed again.

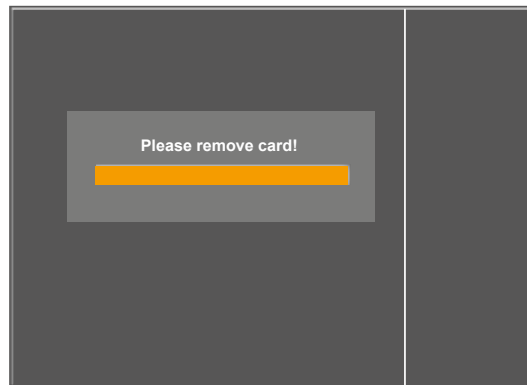

Figure 9–55: Removing the chip card

"Only Chipcard" Mode

When this mode is selected, training sessions can only be performed when a chip card is inserted.

The training parameters are usually defined by physicians/therapists and saved to the chip card.

The training results are directly written back to the chip card.

"Only Chipcard + Memory" Mode

This mode is almost identical with the "Only Chipcard" mode (see above).

Additionally, training results can be temporarily stored in the memory of the ergometer in this mode.

Practical workflow:

- 1) The physician/therapist creates a chip card using the opticare software. The data on the card are the patient demographics and a training protocol specifically configured for this particular patient.
- 2) The patient inserts the chip card in the ergometer and completes the training session. The training results are directly written to the chip card.
- 3) The patient informs the physician/therapist of the results. The patient hands the chip card over to the physician/therapist at the latest when the card is full.
- 4) The physician/therapist analyzes the training results and modifies the training protocol if necessary.
- 5) While the training results on the chip card are analyzed by the physician/therapist, the patient can continue with the training sessions. The training results are stored in the memory of the ergometer.
- 6) As soon as a training result is saved in the memory of the ergometer, the patient is logged in. This means that the ergometer will not accept the chip card of another patient.
- 7) After modifying the training protocol, if applicable, and deleting the training results, the physician/therapist hands the analyzed chip card back to the patient.
- 8) The patient inserts the chip card in the ergometer. First of all, the training results stored in the memory of the ergometer are saved to the chip card. Then the training protocol modified by the physician/therapist is imported.
- 9) The patient exercises with the new, modified training protocol. The training results are directly written to the chip card again.
- 10) This procedure from step 3 onwards can be repeated indefinitely.

9.2.5 Manual

In this operating mode the user has complete control over the ergometer and initiates blood pressure measurements.

Pressing the [Start] key initiates the exercise test, the [+ 5 W] and [- 5 W] keys are used to control the load. The actual load change can be set in the configuration menu between +/- 1 W and +/- 25 W (see chapter 9.2.6 "Setup", section "Load Change" on page) 70.

A blood pressure measurement is initiated with the [RR] key.

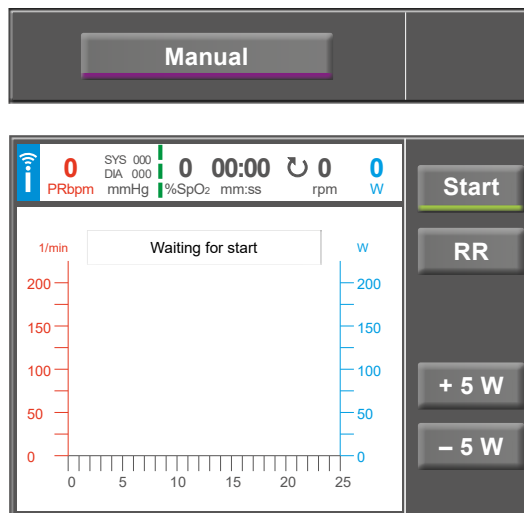

Figure 9 – 56: Starting a manual test

Terminating the Manual Mode

The exercise test can be terminated manually at any time with the [Stop] key.

The load will immediately drop to 0 watt.

There is no recovery phase in the manual mode.

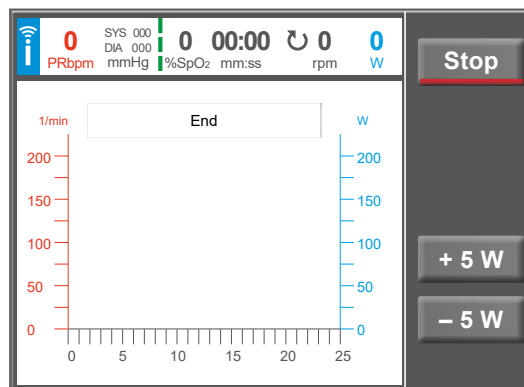

Figure 9 – 57: Terminating a manual test

9.2.6 Setup

The [Setup] key opens the configuration menu where various program functions can be defined.

To edit a setting, touch the corresponding menu item on the display.

Confirm inputs with the [✓] key and exit menus with the [✕] key.

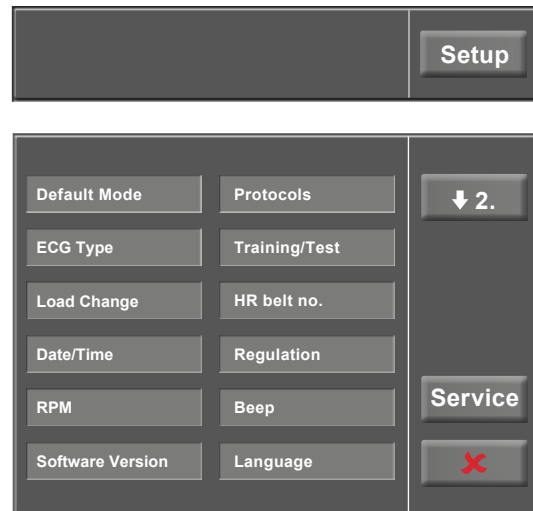

Figure 9–58: Setup menu, screen 1

Default Mode

Select the operating mode to be activated when the ergometer is turned on:

- PC Mode
- Ergometry
- Training/Test
- Manual

and confirm the selection with the [✓] key.

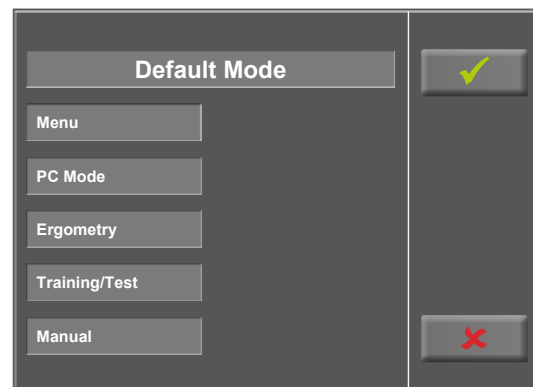

Figure 9–59: Setup – default mode

ECG Type

The selected ECG Type determines the communication method with the ECG recorder, PC-based ECG system, etc.

To prevent an accidental change, this setting is protected with a password.

A submenu opens when you touch ECG Type on the display. Enter the code number "3" via the numeric keypad and confirm with the [✓] key.

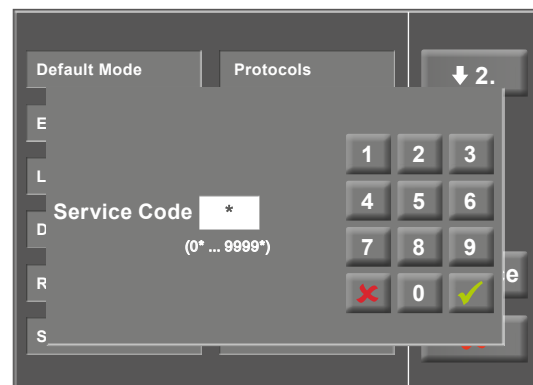

Figure 9–60: Setup menu

9 Control Terminal T

The following communication modes are supported:

- **Analog with pulse**
Remote start mode; before advancing to the next load level, the ergometer generates a control pulse and sends the corresponding data via the interface.
- **Analog/Digital**
An analog voltage controls the load – blood pressure measurements can be initiated with digital commands.
- **Digital** (default)
The communication with the ergometer is entirely controlled with digital commands.
- **Analog IN-OUT**
The entire communication (load control and BP measurements) is controlled with analog signals. No digital data will be sent.

Choose the appropriate communication mode and confirm with the [✓] key.

Load Change

With this function, you select the increments for load changes.

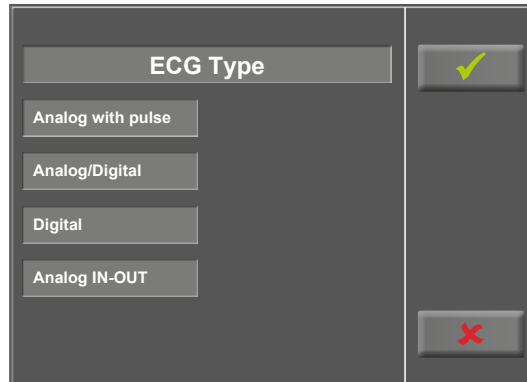

Figure 9 – 61: Setup – ECG type

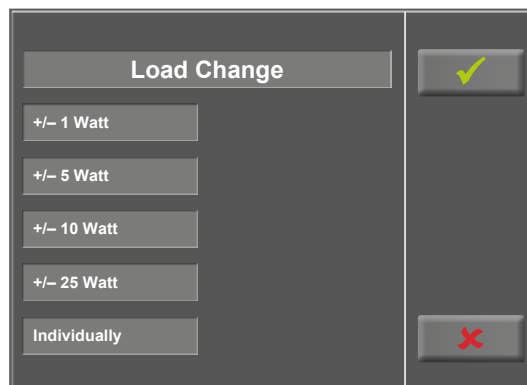

Figure 9 – 62: Setup – load change

Date/Time

Touch the respective fields to adjust date and time.

Enter day, month, year as well as hours, minutes and seconds via the numeric keypad.

Inputs are confirmed with the [✓] key.

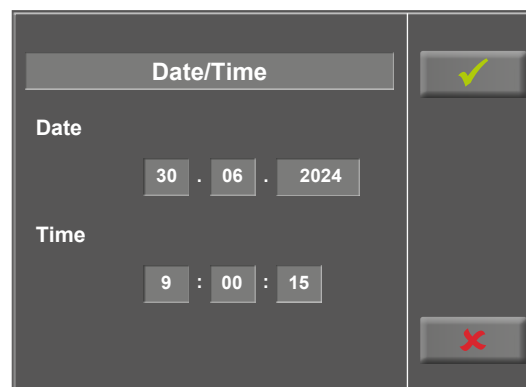

Figure 9–63: Setup – date and time, screen 1

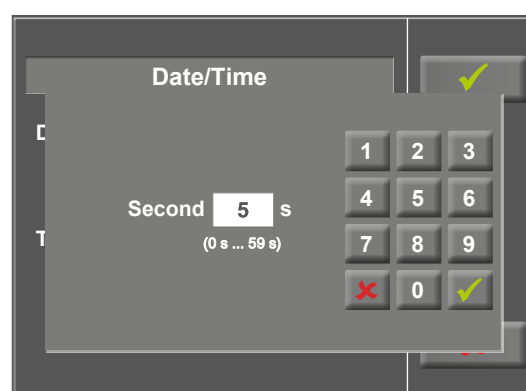

Figure 9–64: Setup – date and time, screen 2

RPM

In this menu, you determine the limits for the RPM indication.

The 3 LEDs on the control panel show the patient whether the pedal speed is high, low or correct.

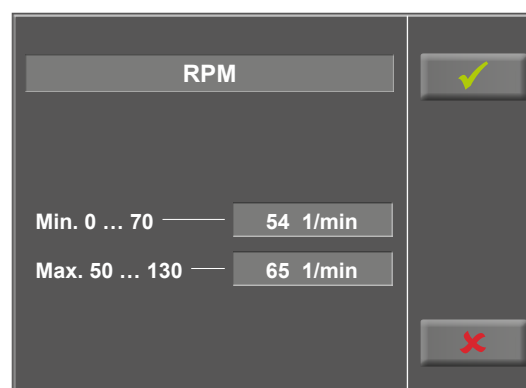

Figure 9–65: Setup – RPM, screen 1

9 Control Terminal T

Touch the light gray field to the right of Min. or Max. and enter the value via the numeric keypad.

Confirm the input with the [✓] key or cancel the input with the [✗] key.

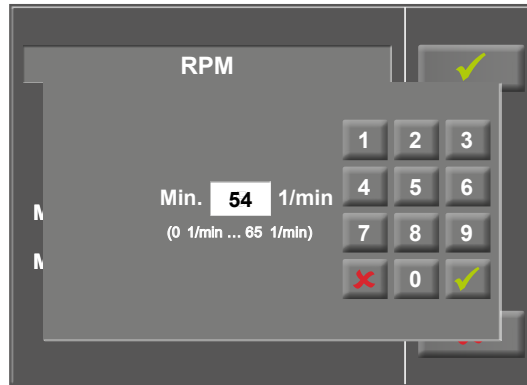

Figure 9–66: Setup – RPM, screen 2

Software Version

This menu shows the software version and the date of the next technical inspection of the measuring system (MTK).

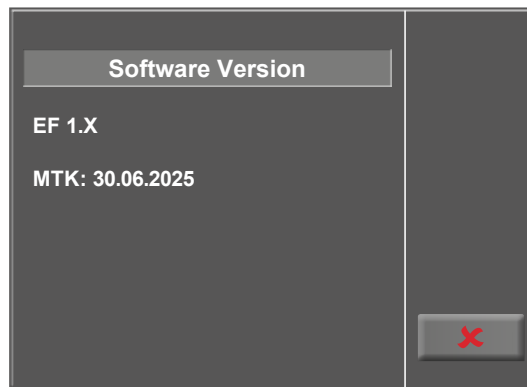

Figure 9–67: Setup – software version

Protocols

The first 5 exercise test protocols (WHO, BAL, Hollm, Std Fr and Standard) are preconfigured, but all protocols in the list are editable.



Figure 9–68: Setup – protocols, screen 1

To reach the level for editing of the individual protocol parameters, first touch the protocol that you want to modify (e.g., [5. Protocol 6]), and then touch the [Edit] key.



Figure 9-69: Setup – protocols, screen 2

To change the name of a protocol, touch the protocol name and enter the new name from the keypad. Confirm your inputs with the [✓] key.

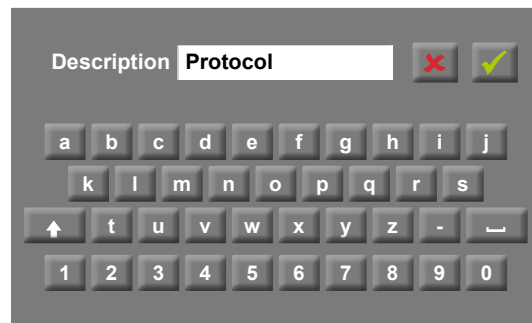

Figure 9-70: Setup – protocols, screen 3

At Type, you can choose [Step ↕], [Ramp ↕] or [Inactive ↕]. You scroll through the Type options with the [↕] key.

When choosing the Step type (load increase in steps), define the basic load (from 6 to 100 W), the stage time (from 1 to 30 min) and the stage rate (increment, from 1 to 400 W). When choosing the Ramp type (continuous load increase), define the basic load (from 6 to 100 W) and the load increase (from 1 to 50 W).

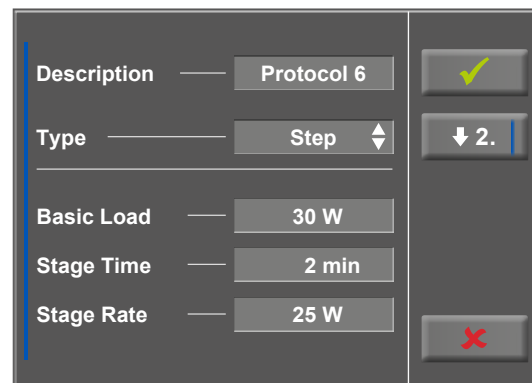

Figure 9-71: Setup – protocols, screen 4

To configure the protocol parameters (light gray fields), touch one of the parameters. Edit the parameter as appropriate and confirm the modification with the [✓] key.

Touch the Cancel key [✕] to exit the menu item.

With the [↓ 2.] and [↑ 1.] keys, you toggle between the different screens.

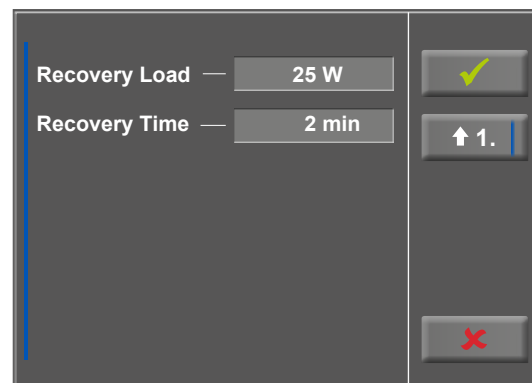

Figure 9-72: Setup – protocols, screen 5

Training/Test

To edit the protocol parameters, first touch the Training/Test protocol you want to edit.

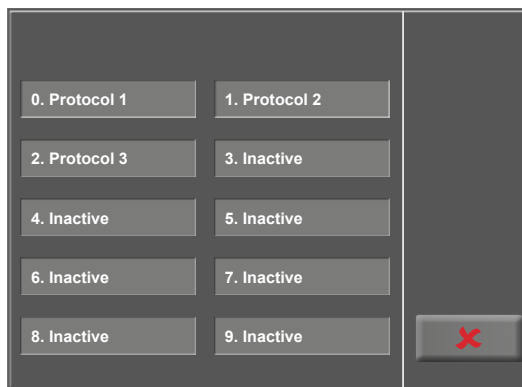

Figure 9–73: Selecting the training/test protocol

Then press the [Edit] key.

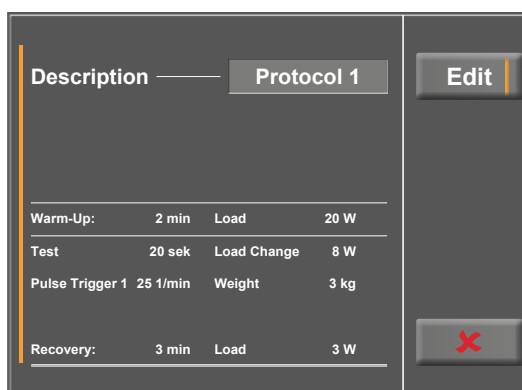

Figure 9–74: Editing the training/test protocol

The individual parameters (light gray fields) can now be edited by touching the display or by repeatedly tapping [↕]. If you need to input characters (numbers or letters), an (alpha-) numeric keypad or a keyboard will be displayed.

The options for Type are [Pulse ↕], [Constant ↕], [Interval ↕], [Interval HR ↕], [Countdown ↕], [Ramp test ↕], [PWC Test 1 ↕], [PWC Test 2 ↕], [PWC Test 3 ↕] and [Inactive ↕]. You scroll through the Type options by tapping the [↕] key. Configure the parameters as required by the selected type.

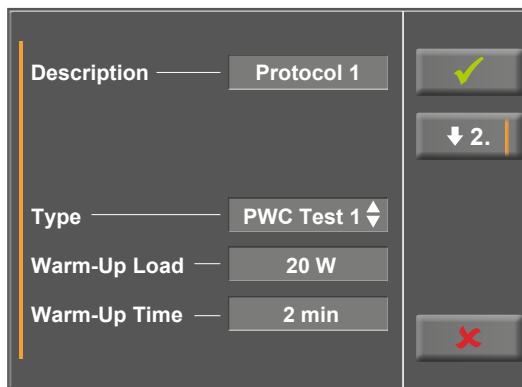

Figure 9–75: Editing parameters, screen 1

With the [▼] key (arrow down, [▼2.] or [▼3.]), you advance to the next menu level where more parameters can be configured. With the [▲] key (arrow up, [▲1.] or [▲2.]), you return to the previous screen of the menu.

Inputs are confirmed with the [✓] key.

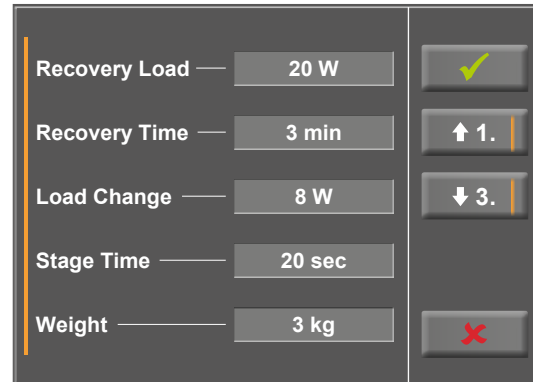

Figure 9–76: Editing parameters, screen 2

HR Belt Number

If the test subject wears a chest strap to measure the heart rate during the training, the corresponding chest strap number must be entered here. You will find the number on the back of the housing. It is the unique identifier for this particular belt.

With the [▼2.] and [▲1.] keys, you toggle between the menu screens.

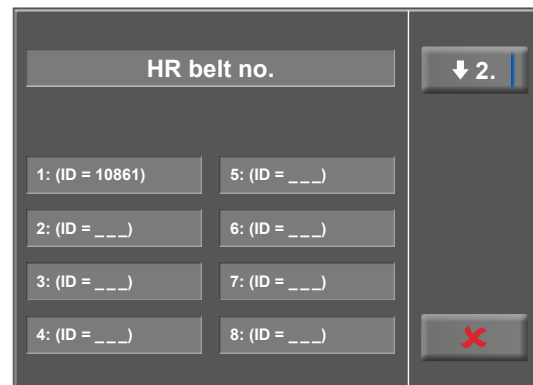

Figure 9–77: Setup – HR belt number, screen 1



Figure 9–78: Setup – HR belt number, screen 2

Regulation

These settings are required for pulse-controlled training sessions that are directly configured at the ergoselect (not via chip card etc.) (see figure 9 – 27, Type [Pulse ↕] on page 57):

At Regulation, you can specify the load details, such as

- load control (gradual, normal, steep)
- duration: load + (0 min to 15 min) and
- duration load – (0 min to 15 min)

You scroll through the load control options (flat, normal, steep) by tapping the light gray text field.

When you touch the light gray fields to the right of "Duration: load +" or "Duration: load –", the time can be entered via the numeric keypad.

Inputs are confirmed with the [✓] key.

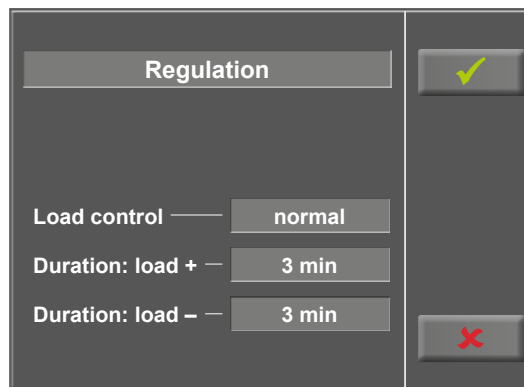

Figure 9 – 79: Setup – regulation method, screen 1

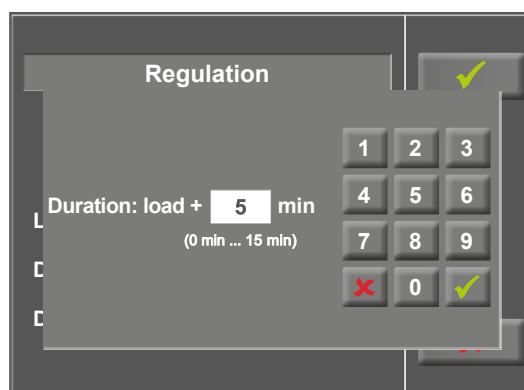

Figure 9 – 80: Setup – regulation method, screen 2

Beep

The audio signal emitted during blood pressure measurements can be turned on and off.



Figure 9 – 81: Setup – beep

Language

Here you choose the language for the user interface.



Figure 9–82: Setup – language

On screen 2 of the *Setup* menu, further settings can be configured (see figure 9–83).

To edit a setting, touch the corresponding menu item on the display.

Confirm inputs with the [✓] key and exit menus with the [✕] key.

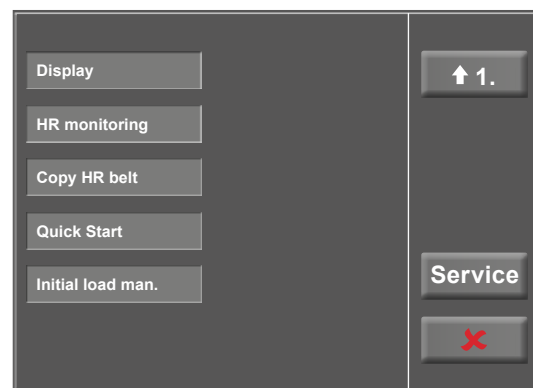

Figure 9–83: Setup menu, screen 2

Display

Switch the pulse readout on or off.

Select the blood pressure unit: mmHg (millimeter of mercury) or kPa (kilopascal).



Figure 9–84: Setup – display

HR Monitoring

These parameters are required for the "Interval HR" training mode.

If the heart rate exceeds the "Heart Rate" value (see figure 9 – 37, Type [Interval HR ↕] on page 60) by the "Threshold" value for the duration of the "Delay", the load for the next interval will be reduced:

- by a relative value [%] or
- by an absolute value [W]

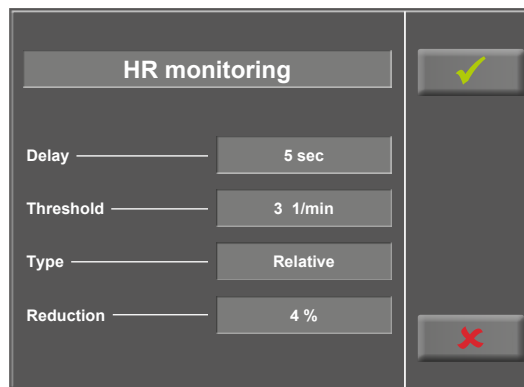

Figure 9 – 85: Defining the heart-rate monitoring parameters

Copy HR Belt

This function can be used to transfer the ID numbers of all 16 stored heart rate belts to another ergometer.

To do this, insert a chip card and then press the *Export to CPC* key. All ID numbers will be copied from the memory of the ergometer to the chip card. First, however, check that there are no training data on the chip card, as they will be overwritten and become useless.

Then remove the chip card and insert it in the next ergometer. To import the ID number, press the *Import from CPC* key. All the ID numbers on the chip card will now be transferred to the ergometer memory. The ID numbers can be imported at any number of devices.

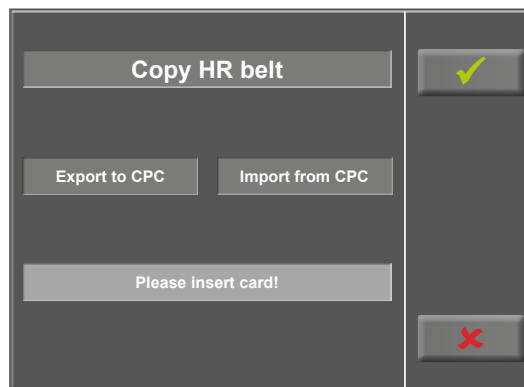

Figure 9 – 86: Copy HR belt

Quick Start

When the *Quick Start* function is activated, a manual training session will start automatically only after the pedal speed exceeds 30 rpm.

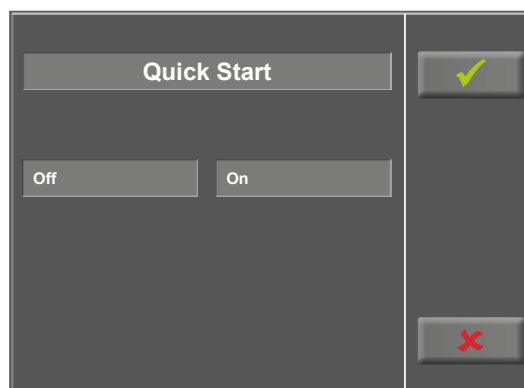

Figure 9 – 87: Activating the Quick Start mode

Initial Load for a Manual Training

In this menu, the initial load for a manual training session is defined.

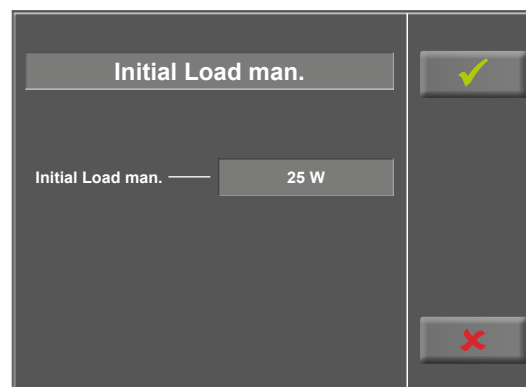

Figure 9–88: Initial load, manual training, screen 1

After touching the light gray field to the right of *Initial Load man.* (see figure 9–88), the value can be entered via the numeric keypad.

With the [✓] key, the input is confirmed, with the [✕] key, it is discarded.

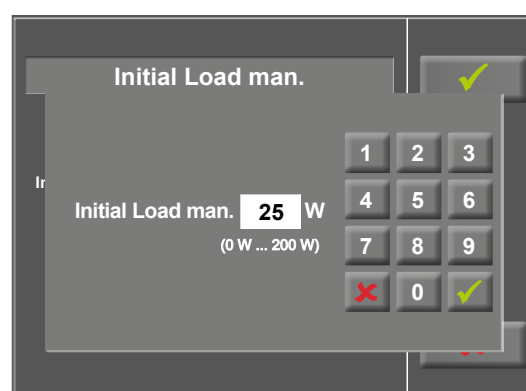

Figure 9–89: Initial load, manual training, screen 2

10 Accessory/Compatible Devices

10.1 Accessories Overview

Part no.	Designation	Application	Information
705802	Anti-tipping device for ergoselect 4/5, white	Stability	optional
705024	Standard saddle with standard receptacle (Ø 22 mm)	Saddle	included*
705084	Horizontal seat adjustment	Ergonomics	optional
705942	Pedal cranks, adjustable w/o tools	Ergonomics	optional
705901	Storage basket with holder (for ergoselect 4/5)	Comfort	optional
705308	Quick release adapter (w/o saddle)	Comfort	optional
471110	Pediatric seat with standard receptacle (Ø 22 standard mm)	Seat for pediatric exercise test	optional
705080	Seat adjustment for pediatric exercise test	Pediatric exercise test	optional
705944	Comfort pedal straps, with ratchet (set)	Pedal	optional
705786	Pedal, extra wide, with Comfort pedal straps (set)	Pedal	optional
471107	Racing saddle with standard receptacle (Ø 22 mm)	Saddle Training/Fitness	optional
705810	Blood pressure cuff, metal D-ring, standard	Measurement	included*
705813	Blood pressure cuff, metal D-ring, standard, 2-meter tube	Measurement	optional
705811	Blood pressure cuff, metal D-ring, large	Measurement	optional
705814	Blood pressure cuff, metal D-ring, large, 2-meter tube	Measurement	optional
705812	Blood pressure cuff, metal D-ring, pediatric	Measurement	optional
707336	SoftCap® SpO ₂ sensor, large, cable 1.2 m; type SC7500, bluepoint ref.: 6020132004	Measurement	included*
707337	SoftCap® SpO ₂ sensor, middle, cable 1.2 m; type SC7500, bluepoint ref.: 6020132010	Measurement	optional
707338	SpO ₂ extension cable 1.2 m; model: XT6500, bluepoint ref.: 1020132275	Measurement	optional
707339	SoftFlap® SpO ₂ sensor, cable 1.2 m; type SF7500, bluepoint ref.: 6020132002	Measurement	optional
705082	Suction electrode leadwire System 2000, Rehab kit 1.3 m, complete	Heart rate measurement	included*

* with corresponding option

705081	Electrode leadwires (1.30 m) with snap fastener, System 2000, set of 3	Heart rate measurement	included*
705362	ERGOLINE pulse chest strap (digital: 868 MHz – EU)	Heart rate measurement	included*
705372	Elastic band for ERGOLINE pulse chest strap	Heart rate measurement	included*
705295	Heart-rate chest strap "POLAR"	Heart rate measurement	included*
705093	Connecting cable ergoselect to PC (5 m)	Connection	optional
705094	Connecting cable ergoselect to PC (12 m)	Connection	optional
705464	USB cable for ergoselect II (5m)	Connection	optional
705780	Analog interface (COM module)	Connection	optional
707249	Power cord, functional ground connection, potential equalization	Connection	optional
705838	Potential equalization kit	Connection	optional

* with corresponding option

10.2 Compatible Devices

A large number of ECG and ergospirometry devices as well as PC software programs are compatible with ergoline ergometers via the ergoline interface protocol P10Vnnn.

Please contact service@ergoline.com for more information.

11 Cleaning, Disinfection and General Hygiene Measures

The document "Cleaning and Disinfection ergoline Medical Devices" (Part No. 201000641000) in its most recent version is also part of this manual. This document is exclusively made available for download from the ergoline website www.ergoline.com.

Disinfection

The cleaning of the SpO₂ sensors from "bluepoint medical GmbH & Co. KG" is described in the instructions for use "IFU-01-02-0001". This is enclosed with every sensor.

12 General Product Information

12.1 Checks Before Each Use

Before each use, visually inspect the device for signs of mechanical damage. If you detect damage or impaired functions which may result in a hazard to the patient or the operator, the device must be repaired before it can be used again.

The parts of the device visually inspected shall be free of cracks or signs of damage, abrasion or wear.

The visual inspection includes the following parts of the device:

- housing
- equipment cables and power cord
- membrane keyboard
- electrode insulation and connectors
- input / output ports, plug-in connections
- connecting cables

In addition to the visual inspection the device should be switched on and the proper functioning of the control panel should be verified. This will ensure

- the proper functioning of the device
- the proper functioning of the display.

12.2 Technical Safety Inspections and Inspections of the Measuring System

The technical safety inspections and the inspections of the measuring system must be completed every two years according to the rules of the art by a Service Engineer authorized by ergoline.

Similarly, the automatic sphygmomanometer in the control terminal must be checked and, if necessary, calibrated by an authorized specialist every two years to fulfill legal requirements.

The date of the next inspection is indicated on the inspection sticker attached next to the type plate on the ergometer.



*It is not permitted to use defective devices or damaged cables.
They shall be replaced immediately.*

12.3 Disposal

The product described in this operator manual must not be disposed of as unsorted municipal waste; it must be collected separately.



Please contact your authorized manufacturer ergoline GmbH for information concerning the disposal of your equipment. There is no proof of disposal. Proper disposal is documented by ergoline GmbH.
Consult Operator's Manual!

13 Technical Specifications

13.1 Ergometer

Model	modular ergometer system ergoselect models ergoselect 4, M/P/T, ergoselect 5, M/P/T
Operating mode	continuous operation
Power supply	100 – 240 V~/50 – 60 Hz max. 100 VA (max. 140 VA for ergometers with motor-assisted adjustment of the handlebar)
	<p>specifications of the US power cord: SPT 2x18AWG 125 V/7 A "hospital" or "hospital grade"</p> <p>specifications of the internal backup battery: IEC: CR 2032/3 V 230 mAh</p>
Braking principle	computer-controlled eddy current brake with torque measurement; speed independent to DIN VDE 0750-0238
Load range	6 ... 999 Watt, speed independent (see diagrams on page 90)
Speed range	30 ... 130 RPM
Load accuracy	to DIN VDE 0750-0238
Load increments	user configurable
Internal protocols	<p>Control Terminal P:</p> <ul style="list-style-type: none"> • 5 fixed and 5 user-configurable exercise test protocols • manual load control <p>Control Terminal T:</p> <ul style="list-style-type: none"> • 10 exercise test protocols (5 preconfigured, editable and 5 user-configurable protocols) • 10 additional, user-configurable training/test protocols • manual load control • 3 preconfigured performance tests • Countdown mode
Permitted patient weight	<p>version 1: manual adjustment of the saddle height (standard), up to 160 kg</p> <p>version 2: gas-spring assisted adjustment of the saddle height (option), up to 200 kg</p> <p>version 3: electrical adjustment of the saddle height with digital indication of the current height (option), up to 200 kg</p>
Permitted patient height	<ul style="list-style-type: none"> • approx. 120 – 210 cm • children (from 6 to 12 years of age) if their height and weight is within the limits defined.

Handlebar adjustment	for patient heights from 120 cm to 210 cm, continuous handlebar adjustment over 350°
Handlebar height adjustment	version 1: rigid steering column (standard) version 2: electrical adjustment of the steering column (option)
Crank length	170 mm (adjustable length cranks available as optional accessories)
Displays	version 1: control terminal M with 93 x 70 mm LCD, 128 x 64 pixels and 7-segment RPM display version 2: control terminal P with 93 x 70 mm LCD, 128 x 64 pixels and 7-segment RPM display version 3: control terminal T with TFT LCD touch screen, 165 x 104 mm, 800 x 480 pixels and 7-segment RPM display
Interfaces	PORT 1 (DSUB-9-pole): remote control from PC or ECG recorder remote start of an ECG recorder (option) USB: remote control from PC (driver required) optional: Bluetooth/WLAN/COM module
Dimensions, weight	length: 1030 mm width: 490 mm (width of handlebar approx. 530 mm) height: 1140 – 1400 mm weight: approx. 66 kg
Safety standards	DIN EN 60601-1, DIN EN 60601-1-2, DIN VDE 0750-238
Protection class/degree of protection	II  / B (ergometer) BF (blood pressure module / SpO ₂) BF (ECG)
Classification	class IIa to 93/42 EEC
RF emission	class B to DIN EN 55011 / 5.0 DIN EN 60601-1-2
Environment	operation: temperature: +10 to +40 °C rel. humidity: 30 to 75 %, no condensation atmospheric pressure: 800 to 1060 hPa transport and storage: temperature: -20 to +70 °C rel. humidity: 10 to 95 %, no condensation atmospheric pressure: 500 to 1060 hPa

13.2 Blood Pressure Module [Option B]

Measuring method	auscultatory method (Korotkov), oscillometric; for resting BP, the results from both measurements are compared for plausibility
Measuring range	systolic pressure: 40 to 280 mmHg diastolic pressure: 40 to 280 mmHg pulse rate: 35 to 230 bpm
Measurement error, systematic	systolic pressure: +/- 3 mmHg diastolic pressure: +/- 3 mmHg (temperature: +10 to +40 °C)
Standard deviation (clinical trial)	systolic/diastolic pressure: 7 mmHg (max.)
Inflation pressure	300 mmHg max.; during inflation the inflation pressure automatically adapts to patient's BP
Inflation rate	between approx. 6 seconds (to 140 mmHg) and approx. 18 seconds (to 300 mmHg)
Max. cuff pressure	300 mmHg
Cuff deflation method	pulse-dependent deflation rate approx. 3 mmHg/beat or approx. 3 mmHg/s
Calibration	calibration with external pressure meter
Artifact rejection	automatic artifact rejection

13.3 SpO₂ Module [Option S]

13.3.1 Functional measurement range

SpO ₂	0 – 100%
Pulse Rate	Standard Mode: 30 – 240 bpm
Perfusion Index	OEM III: 0.1 – 20 % (no motion)

13.3.2 Accuracy

SpO₂⁶	0 – 100 %	70 – 100 %:	Arms ≤ 2% (no motion, incl. low perfusion ³) ^{1, 4}
		60 – 80 %:	Arms ≤ 2.5% (no motion, incl. low perfusion ³) ^{1, 4}
		70 – 100 %:	Arms ≤ 3% (motion condition) ²
		< 60 %:	unspecified
Pulse Rate	Standard Mode: 30 – 240 bpm:	A _{rms} ≤ 2 bpm (no motion, incl. low perfusion ³) ⁵ A _{rms} ≤ 3 bpm (motion condition ²)	

- 1) Pulse oximeter measurements are statistically distributed. A_{rms} accuracy is a statistical calculation of the differences between device measurements and reference measurements. Approximately two-thirds of device measurements are expected to fall within ± A_{rms} of the reference measurements.
- 2) Tested with all Fluke Index II Oximeter tester motion patterns with pattern specific motion frequency of 0.5 Hz to 6 Hz at perfusion PI: 0.65% to 5% including non-repetitive motion and motion repeating every 0.5 Hz.
- 3) Tested with Fluke ProSim 8 Oximeter tester at infrared percentage modulation PI: 0.7% to 0.1%.
- 4) Applies to reusable SMARTsat[®] sensors, refer to sensor instructions for use for sensor specific accuracy claims. SpO₂ accuracy is validated by clinical accuracy studies on healthy adult male and female test subjects of age 21 to 32 with skin pigmentation ranging from light to dark over the specified functional oxygen saturation range.
- 5) Pulse rate accuracy was verified by simulated bench tests with Fluke ProSim 8 Oximeter tester to ensure that the entire range was verified.
- 6) Arterial functional oxygen saturation

13.3.3 Response Time

Parameter	Specification		
Display of first value	The time until the first value is displayed after application depends on the measurement conditions (perfusion, motion artifacts) and is in the following range: SpO ₂ : 3 to 7 s; Puls Rate: 5 to 8 s.		
Data update period	Typically, the displayed data update period is 1 s. The data update is delayed in case no new valid data is available, e.g. due to excessive signal distortion. The longest data update period is 28 s.		
Response time mode	Motion tolerance performance	Average response time	
Standard (default)	Motion resistant	SpO ₂ : 8 sec.	Puls rate (bpm): 10 sec.

13.4 ECG Module [Option A]

Algorithm for calculation of the heart rate using the ECG signal	The heart rate is calculated with the Pan Tompkins algorithm for QRS detection.
Type of protection	BF
Input resistance	> 2.5 MΩ
Frequency range	0.65 to 40 Hz
Measuring range	± 10 mV
Common mode rejection	> 100 dB

Noise level	$\leq 20 \mu\text{V}$
AD Converter	12-bit
Sampling rate	250 Hz

13.5 Exercise Test Protocols

Protocol	Basic Load [W]	Stage Time [min]	Load Stage [W]	Recovery Load [W]	Recovery Time [min]
1. WHO	25	2	25	25	99
2. BAL	50	3	50	25	99
3. Hollmann	30	3	40	25	99
4. STD France	30	3	30	25	99
5. Standard	20	1	25	25	99
6. – 15. (user-configurable)	25	2	25	25	99
Adjustment Range	20 – 100	1 – 30	1 – 400	20 – 100 (*)	1 – 99

(*) With Control Terminal P, the recovery load is fixed at 25 W.

13.6 Test Protocols (control terminal T only)

Protocol	Basic Load [W]	Duration [sec]	Load Increment [W]	Stage Time [sec]	Recovery Load [W]	Recovery Time [min]
Ramp test	0	120	25	10	25	99
PWC-130 (*)	25	0	25	120	25	99
PWC-150 (*)	50	0	25	120	25	99
PWC-170 (*)	50	0	50	120	25	99

(*) the protocol advances to the recovery phase as soon as the target heart rate (130/150/170) is reached

13.7 Family of characteristics of the braking torque control range

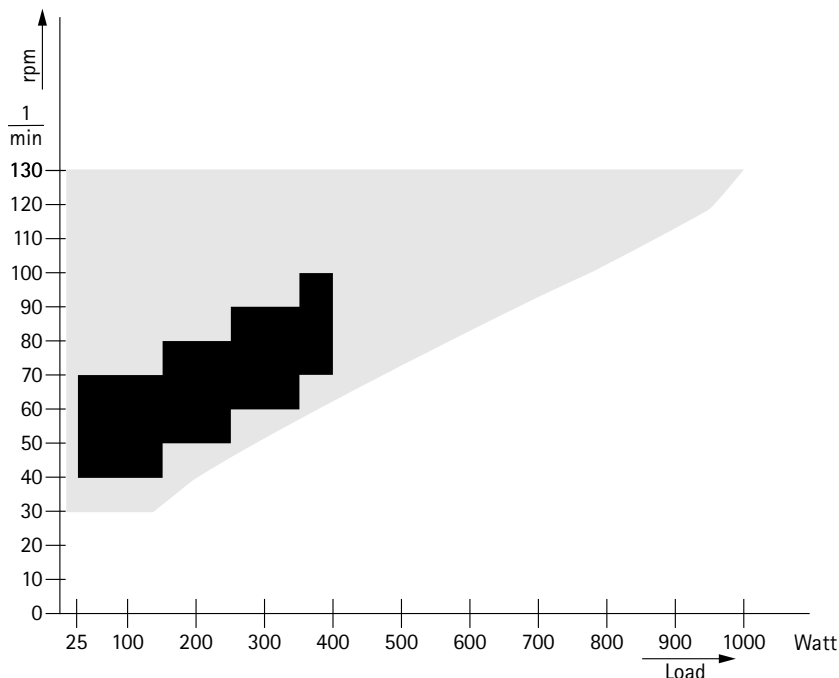

Figure 13 – 1: black: speed-independent range to DIN VDE 0750-0238
 black + gray: speed-independent range of the ergoselect ergometer

13.8 Family of characteristics of the load periods according to IEC 60601-1

Watt	Time (min)													
999	9	28	6	31	6	31	6	31	6	31	6	31	6	31
800	12	23	8	27	8	27	8	27	8	27	8	27	8	27
700	19	18	9	20	9	20	9	20	9	20	9	20	9	20
600	33	13	10	15	10	15	10	15	10	15	10	15	10	15
500	68	10	17	10	17	10	17	10	17	10	17	10	17	10
400	115	10	30	10	30	10	30	10	30	10	30	10	30	10
350	∞													
300	∞													

Figure 13 – 2: Under permanent load, the load periods and pauses (white) shall be observed.

14 Electromagnetic Compatibility EN 60601-1-2

Changes or modifications to this system not expressly approved by ergoline could cause EMC issues with this or other equipment.

This system is designed to comply with applicable regulations regarding EMC.

Its compliance with these requirements has been verified. It needs to be installed and put into service according to the EMC information stated as follows.



WARNING

RF Interference

Use of portable phones or other radio frequency (RF) emitting equipment near the system may cause unexpected or adverse operation.



CAUTION

Equipment Malfunction

The equipment or system should not be used adjacent to, or stacked with, other equipment. If adjacent or stacked use is necessary, the equipment or system should be tested to verify normal operation in the configuration in which it is being used.

Guidance and Manufacturer's Declaration – Electromagnetic Emissions

The ergoselect ergometer is intended for use in the electromagnetic environment specified below. It is the responsibility of the customer or user to ensure that the ergoselect ergometer is used in such an environment.

Emissions Test	Compliance	Electromagnetic Environment – Guidance
RF emissions to EN 55011	Group 1	The ergoselect ergometer uses RF energy only for its internal function. Therefore, its RF emissions are very low and are not likely to cause any interference in nearby electronic equipment.
RF emissions to EN 55011	Class B	The ergoselect ergometer is suitable for use in all establishments, including domestic and those directly connected to the public low-voltage power supply network that supplies buildings used for domestic purposes.
Harmonic emissions to EN 61000-3-2	Class A	
Voltage fluctuations/flicker emissions to EN 61000-3-3	Complies	

Guidance and Manufacturer's Declaration – Electromagnetic Immunity			
The ergoselect ergometer is intended for use in the electromagnetic environment specified below. It is the responsibility of the customer or user to ensure that the ergoselect ergometer is used in such an environment.			
Immunity Test	IEC 60601 Test Level	Compliance Level	Electromagnetic Environment – Guidance
Electrostatic discharge (ESD) to EN 61000-4-2	± 8 kV contact ± 15 kV air	± 8 kV ± 15 kV	Floors should be wood, concrete or ceramic tile. If floors are covered with synthetic material, the relative humidity should be at least 30 %.
Electrical fast transient/burst to EN 61000-4-4	± 2 kV for power supply lines ± 1 kV for input and output lines	± 2 kV passed	Mains power quality should be that of a typical commercial or hospital environment.
Surge to EN 61000-4-5	± 1 kV differential mode ± 2 kV common mode	± 1 kV N/A	Mains power quality should be that of a typical commercial or hospital environment.
Voltage dips, short interruptions and voltage variations on power supply input lines to EN 61000-4-11	< 5 % UT (>95 % dip in UT) for 0.5 cycles 40 % UT (60 % dip in UT) for 5 cycles 70 % UT (30 % dip in UT) for 25 cycles < 5 % UT (> 95 % dip in UT) for 5 seconds	< 5 % UT 40 % UT 70 % UT < 5 % UT	Mains power quality should be that of a typical commercial or hospital environment. If the user of the ergoselect ergometer requires continued operation during power mains interruptions, it is recommended that the ergoselect ergometer be powered from an uninterruptible power supply or a battery.
Power frequency (50/60 Hz) magnetic field to EN 61000-4-8	3 A/m	passed	Power frequency magnetic fields should be at levels characteristic of a typical location in a typical commercial or hospital environment. The ergoselect ergometer has no components susceptible to magnetic fields.
Note: UT is the a.c. mains voltage prior to application of the test level.			

Guidance and Manufacturer's Declaration – Electromagnetic Immunity			
The ergoselect ergometer is intended for use in the electromagnetic environment specified below. It is the responsibility of the customer or user to ensure that the ergoselect ergometer is used in such an environment.			
Immunity Test	IEC 60601 Test Level	Compliance Level	Electromagnetic Environment – Guidance
<p>Conducted RF to EN 61000-4-6</p> <p>Radiated RF to EN 61000-4-3</p>	<p>3 Vrms 150 kHz to 80 MHz</p> <p>3 V/m 80 MHz to 2.5 GHz</p>	<p>3 V</p> <p>3 V/m</p>	<p>Portable and mobile RF communications equipment should be used no closer to any part of the ergoselect ergometer, including cables, than the recommended separation distance calculated from the equation applicable to the frequency of the transmitter.</p> <p>Recommended separation distance: $d = 1.2 \sqrt{P}$ $d = 1.2 \sqrt{P}$ for 80 MHz to 800 MHz $d = 2.3 \sqrt{P}$ for 800 MHz to 2.5 GHz</p> <p>where P is the maximum output power rating of the transmitter in watts (W) according to the transmitter manufacturer and d is the recommended separation distance in meters (m).</p> <p>Field strengths from fixed RF transmitters, as determined by an electromagnetic site survey^{a)}, should be less than the compliance level in each frequency range^{b)}.</p> <p>Interference may occur in the vicinity of equipment marked with the following symbol:</p> 
<p>Note 1: At 80 MHz and 800 MHz, the higher frequency range applies.</p> <p>Note 2: These guidelines may not apply in all situations. Electromagnetic propagation is affected by absorption and reflection from structures, objects, and people.</p>			
<p>a) Field strengths from fixed transmitters, such as base stations for radio (cellular/cordless) telephones and land mobile radio, AM and FM radio broadcast and TV broadcast cannot be predicted theoretically with accuracy. To assess the electromagnetic environment due to fixed RF transmitters, an electromagnetic site survey should be considered. If the measured field strength in the location in which the ergoselect ergometer is used exceeds the applicable RF compliance level above, the ergoselect ergometer should be observed to verify normal operation. If abnormal performance is observed, additional measures may be necessary, such as re-orienting or relocating the ergoselect ergometer.</p> <p>b) Over the frequency range from 150 kHz to 80 MHz, field strengths should be less than 3 V/m.</p>			

Recommended separation distances between portable and mobile RF communications equipment and the ergoselect ergometer			
The ergoselect ergometer is intended for use in an electromagnetic environment, as specified below, in which radiated RF disturbances are controlled. The customer or the user of the ergoselect ergometer can help prevent electromagnetic interference by maintaining a minimum distance between portable and mobile RF communications equipment (transmitters) and the ergoselect ergometer as recommended below, according to the maximum output power of the communications equipment.			
Rated maximum output power of transmitter [W]	Separation Distance according to Frequency of Transmitter [m]		
	150 kHz to 80 MHz $d = 1.2 \sqrt{P}$	80 MHz to 800 MHz $d = 1.2 \sqrt{P}$	800 MHz to 2.5 GHz $d = 2.3 \sqrt{P}$
0.01	0.12	0.12	0.23
0.1	0.37	0.37	0.74
1	1.17	1.17	2.33
10	3.7	3.7	7.37
100	11.7	11.7	23.3
For transmitters rated at a maximum output power not listed above, the recommended separation distance d in meters (m) can be estimated using the equation applicable to the frequency of the transmitter, where P is the maximum output power rating of the transmitter in watts (W) according to the transmitter manufacturer.			
<p>Note 1: At 80 MHz and 800 MHz, the higher frequency range applies.</p> <p>Note 2: These guidelines may not apply in all situations. Electromagnetic propagation is affected by absorption and reflection from structures, objects, and people.</p>			



ergoline GmbH
Lindenstraße 5
72475 Bitz
Germany

Tel.: +49-(0) 7431 98 94 - 0
Fax: +49-(0) 7431 98 94 - 128
e-mail: info@ergoline.com
http: www.ergoline.com