



VERSION: 250406

DATE: 2025-04-06



Norav Users Guide PC-ECG 1200**For Models: 1200S/M/HR/W, Blue-ECG, NR-1207-E and NR-1207-3, software version: 5.986**

Document Number: NV-54/PCECG1200

Revision: 250406

No part of this publication may be reproduced in any material form (including photocopying or storing it in any medium by electronic means whether or not transiently or incidentally to some other use of this publication) without the prior written permission of the copyright owner, or under the terms of a license issued by the copyright owner.

The information contained in this document is subject to change without notice. Norav is neither responsible for nor liable to anyone in connection with this document.

© 2025 Norav Medical. All rights reserved.

Manufacturer and Contact Information**Manufactured by:**

Norav Medical Inc.

601 N. Congress Ave, Suite

105

Delray Beach FL 33445

USA

Phone: +1 561-274-4242

E-mail: info@norav.com**Standards Compliance**

The software complies with Standards for Analysis of Ventricular Late Potentials Using High Resolution or Signal Averaged Electrocardiography, published in 1991 by the Task Force Committee of the European Society of Cardiology, the American Heart Association, and the American College of Cardiology.

This product fulfills the requirements of the Regulation (EU) 2017/745 (MDR) of the European Parliament and of the Council on Medical Devices as well as the requirements of the Regulation UK MDR 2002 (Statutory Instruments 2002 No. 618 Consumer Protection), as amended.

**Federal Law restricts this device to sale by or on the order of a licensed physician or healthcare provider****Caution**

Disclaimer

This system is intended as a decision support system for persons who have received appropriate medical training and should not be used as a sole basis for making clinical decisions pertaining to patient diagnosis, care, or management. Any application of medical information from the system, other than the original design or intended use thereof, is not advised and considered a misuse of the software product.

Norav Limited Warranty

Norav products are warranted to be free from manufacturing and material defects for a period of one (1) year from the date of shipment from Norav or the dealer to the original purchaser.

Excluded from this warranty are expendable supply items including, but not limited to, electrodes, lead wires, patient cables, and batteries. This warranty does not apply to any product that Norav determines that it has been modified or damaged by the customer.

Except for the express warranties stated above, Norav disclaims all warranties including implied warranties of merchantability and fitness. The stated express warranties are in lieu of all obligations or liabilities on the part of Norav for damages, including but not limited to, special, indirect, or consequential, arising out of or in connection with the use or performance of Norav products.

Any action for breach of warranty shall be commenced within one (1) year of said breach or be forever barred. Any repairs made to the product that are not covered by the warranty shall be billed to the customer.

For service or technical support contact your local supplier or Norav Medical.

Document History

Version	Date	Updates	Changed by
060408	06/04/2008		David
060708	06/07/08	Norav Logo; Document history; RS232 controlled treadmill types;	David
100708	10/07/2008	Stress –Dynamic ST function added	David
181110	18/11/2010	Updates	David
020211	02/02/2011	Updates - safety	David
080511	08/05/2011	Updates – EMC data	David
040613	04/06/2013	Updates of v55	Alex
170613	17/06/2013	CORTEX CPET interface description	Alex
180913	18/09/2013	HRV Interface changes	Alex
080714	08/07/2014	Update – Tango M2 instruction changed	Alex
211014	21/10/2014	Warnings update (regarding IEC60950 compatible PC)	David
171114	17/11/2014	Update supported treadmills list (ST-65 added)	Alex
210515	21/05/2015	Updated intended use	David
140116	14/01/2016	Stress v56 new GUI description	Alex
220316	22/03/2016	Stress the XML Auto Save option description	Alex
111216	11/12/2016	Rest: NR-1207-E device support added	Alex
020317	02/03/2017	NR-1207-E notes changed; ECG Electrodes note added	Alex
260417	26/04/2017	New logo picture	Alex
190617	19/06/2017	500/1000 sample rate in Stress	Alex
311017	31/10/2017	EMC Table, Temperature, Warnings, Maintenance	Boris
060119	06/01/2019	Trnsf.txt format description updated	Alex
100219	10/02/2019	Stress ECG and Resting ECG chapters updated	Alex
070319	07/03/2019	Text corrections	Alex
170319	17/03/2019	Stress: Konami ergometer support added	Alex
120519	12/05/2019	Rest: two QTc formulas	Alex
210719	21/07/2019	Rest: enable Measurements ECG application	Alex
260819	26/08/2019	Text corrections	Alex
061019	06/10/2019	NR-1207-3 model support; the Lead Check function added	Alex
251119	25/11/2019	Norav GmbH office new address	Alex
100220	10/02/2020	ECG leadwires cleaning and disinfecting instructions added	Alex
200420	20/04/2020	Pacemaker detection feature added in Rest and Stress	Alex
200720	20/07/2020	Rest & Stress new features	Alex
210120	20/01/2021	New features	Alex
210531	31/05/2021	Labels added	Alex
211130	31/07/2021	Rest: 15-lead ECG, Derived 12-lead ECG from 5-Electrodes cable	Alex
220228	28/02/2022	Device Cleaning-Disinfecting instruction updated	Alex
220419	19/04/2022	“Transport Monitor” screen in Rest, SunTech “Aura” BP monitor support	Alex
240630	30/06/2024	Resting ECG and Stress changes- user logon password optional function	Alex
240928	28/09/2024	Technical specifications table updated	Alex
241031	31/10/2024	Copyright, Contact Information, and Contraindications for Use and Adverse effects section updates. Minor text fixes.	Anton
241107	07/11/2024	DICOM Communication section updated: clarified the effects of ECG or a blank value in the Modality text field on receiving orders. Added images illustrating various scenarios in this section.	Anton
250406	06/04/2025	Copyright section updated; Address section updated; Standards Compliance section updated; UKCA mark added; Cover Page updated.	Anton

Contents

INTRODUCTION	11
Manual Organization.....	11
Document Conventions.....	11
<i>Notes and Cautions</i>	11
<i>Abbreviations and Acronyms</i>	11
<i>Equipment Symbols</i>	12
Indications for Use of the PC-ECG 1200.....	13
Contraindications for Use and Adverse Effects.....	14
OVERVIEW	15
Package Contents.....	15
Programs	16
PC-ECG Models.....	16
Device to Software Option Compatibility	16
Safety Warnings and Precautions	17
Classification Of The Equipment	21
<i>EMC Specifications according to IEC 60601-1-2</i>	22
MAINTENANCE	24
Device Cleaning and Disinfecting.....	25
<i>Manual Cleaning procedure</i>	25
<i>Low level Disinfection procedure</i>	25
ECG Cables and Leadwires Cleaning and Disinfecting.....	25
Sterilization	26
Calibration.....	26
SOFTWARE INSTALLATION	27
System Requirements and Prerequisites	27
<i>PC Minimum Configuration</i>	27
<i>Printers</i>	28
Installing or Updating PC-ECG 1200 Software.....	29
<i>To Install PC-ECG 1200</i>	29
<i>To Uninstall PC-ECG 1200</i>	30
<i>To Free Disk Space and Ensure Smooth Operation</i>	30
Backing up and Restoring Setups and Protocols	31
<i>To Save the Software Setup Configuration</i>	31
<i>To Load the Software Setup Configuration</i>	31
<i>To Save Stress Protocols</i>	31
<i>To Load Stress Protocols</i>	32
<i>To Set Preferences</i>	32
HARDWARE INSTALLATION	33
Installing Model 1200S and Model 1200M.....	33
Installing Model 1200HR	36
Installing Model 1200W.....	37
Installing Model Blue-ECG.....	40
Installing Models NR-1207-E and NR-1207-3.....	42
Connecting an Exercise Device.....	46
<i>To Connect an RS232 Controlled Treadmill/Ergometer</i>	46
<i>To Connect an USB Controlled Treadmill/Ergometer</i>	46
<i>To Connect an Analog Controlled Treadmill/Ergometer</i>	46
<i>Cabling</i>	46

ACCESSORIES INSTALLATION	47
Installation of the Tango M2 Automatic BP Unit.....	47
<i>Verify Correct Cables</i>	47
<i>Connect the Computer Connection Cable (USB or RS232)</i>	48
<i>Connect the ECG Trigger Cable</i>	48
<i>Tango M2 Monitor Setup</i>	48
5. <i>Norav Stress ECG System Setup</i>	48
PATIENT PREPARATION	50
ECG Electrodes.....	50
RESTING ECG	51
Quick Start.....	52
<i>To Perform a New Test</i>	52
<i>Operation with Function Keys and Hotkeys</i>	59
Toolbars and Panels	60
<i>Toolbar Overview</i>	60
<i>ECG Screen View and Filters panel</i>	61
<i>Patient Information panel</i>	62
Resting ECG System Setup.....	63
STRESS ECG	69
<i>To Customize the Display</i>	69
<i>To Lock Screen Window Borders</i>	69
Quick Start.....	70
<i>To Perform a New Test</i>	70
<i>To Print an ECG</i>	71
<i>To Print a Report</i>	71
Operation with Function Keys.....	71
Toolbar Overview.....	72
<i>Main Toolbar</i>	72
<i>Stress Test Commands</i>	73
<i>ECG Screen View and Filters panel</i>	75
<i>Average Viewer Settings</i>	75
<i>Post Processing Options Toolbar</i>	76
Stress ECG System Setup.....	77
Perform the Stress ECG examination	84
<i>PlayBack display</i>	85
<i>Recovery Phase</i>	86
<i>To Display the Review Screen Automatically</i>	86
<i>To Display the Review Screen Manually</i>	86
Viewing Results.....	86
<i>To Save Study Results</i>	86
Understanding Target Heart Rate in Stress Test.....	87
<i>Resting Heart Rate</i>	87
<i>Maximum Predicted Heart Rate</i>	87
<i>Target Heart Rate</i>	87
Metabolic Stress Estimation (METS)	87
Transfer File “Trnsf.txt”	88
<i>To Transfer a File</i>	88
Export the exercise protocol real time values	89
<i>To enable the exercise protocol export file feature</i>	89
Slave operation mode.....	92
<i>To enable the Slave operation mode</i>	92
Additional Features.....	93
<i>To Define Max. HR</i>	93

<i>To Define Worst ST</i>	93
<i>“Dynamic ST” function</i>	93
<i>“Clean Trace” function</i>	93
<i>Configured Summary Report</i>	94
RS232 Controlled Treadmill Types.....	95
RS232 Controlled Bicycle Ergometers	96
LATE POTENTIAL SIGNAL AVERAGING	97
Quick Start.....	98
<i>To Print</i>	98
Operation with Function Keys.....	99
Leads 99	
LP Signal Averaging Setup	100
Toolbar and Menus	102
Interpreting Results	104
<i>Numerical Results</i>	104
MONITORING ECG	105
Quick Start.....	106
<i>To Print</i>	106
<i>Print Study (print a selected time range and leads)</i>	106
Monitoring ECG Setup.....	107
Toolbar and Menus	109
HEART RATE VARIABILITY (HRV)	111
Quick Start.....	112
<i>To Print an HRV Report</i>	112
<i>To Print an ECG</i>	112
HRV Setup	112
Starting a Study	113
<i>To Add or Subtract an Interval</i>	114
<i>To Edit Interval Names</i>	114
<i>To split the whole test into equally timed intervals</i>	114
<i>To Import or Save GDT/BDT Format</i>	114
Results Display.....	115
HRV Interval Measurement.....	115
MEASUREMENTS/ INTERPRETATION (MEANS)	116
Quick Start.....	117
<i>To Start Measurements</i>	117
<i>To Print Reports</i>	117
Performing Changes in Calculations.....	117
<i>To Move the QRS Marker</i>	117
<i>To Add or Remove a Wave Marker</i>	117
<i>To Move the Wave Marker</i>	117
Features	118
<i>To View the Measurements on a QRS</i>	118
<i>To View the Measurements on a Channel</i>	118
<i>To View the Measurements on All Channels for QT</i>	118
Tabular Screen.....	118
Averages Display.....	119
QRS Display	120
Toolbar of Averages/QRS Displays.....	120
Caliper Display	121
Toolbar and Menus	122
NEMS APPLICATION	124

INTERFACING WITH INFORMATION SYSTEMS.....	125
Demographic Data	125
HL7 Format File.....	127
GDT/BDT Type Communication	129
DICOM Communication	130
Saving the Stress Test as a RAW Data (“native binary”) Format File.....	133
Saving the Monitoring ECG Test as a Raw Data (“Native Binary”) Format File.....	134
TECHNICAL SPECIFICATIONS.....	133
REPORT SAMPLES	134
TROUBLESHOOTING	139

List of Figures

FIGURE 1: SAVING THE SOFTWARE SETUP CONFIGURATION.....	31	
FIGURE 2: PC-ECG 1200S / PC-ECG 1200M	33	
FIGURE 3: PATIENT CABLE	34	
FIGURE 4: USB CABLE	34	
FIGURE 5: PC-ECG 1200HR (WITH BUILT-IN USB CABLE)	36	
FIGURE 6: PC-ECG 1200W	37	
FIGURE 7: USB CABLE	37	
FIGURE 8: 1200W BATTERY INSTALLATION.....	38	
FIGURE 9: 1200WR RECEIVER	39	
FIGURE 10: PC-ECG 1200 BLUE-ECG	40	
FIGURE 11: BLUETOOTH ICON ON SYSTEM TRAY	41	
FIGURE 12: PC-ECG NR-1207-E/NR-1207-3.....	42	
FIGURE 13: NR-1207-E / NR-1207-3 PATIENT CABLE CONNECTION.....	43	
FIGURE 14: NR-1207-3 MEMORY CARD INSERTION.....	43	
FIGURE 15: NR-1207-E / NR-1207-3 BATTERY INSTALLATION	44	
FIGURE 16: BLUETOOTH ICON ON SYSTEM TRAY	45	
FIGURE 17: COMPUTER SIDE	FIGURE 18: TANGO M2 SIDE.....	47
FIGURE 19: STRESS ECG SIDE	FIGURE 20: TANGO M2 SIDE.....	47
FIGURE 21: TANGO M2 MONITOR BACK SIDE.....		47
FIGURE 22: RESTING ECG MAIN SCREEN		51
FIGURE 23: STANDARD 12-LEAD RESTING ECG ELECTRODE PLACEMENT.....		52
FIGURE 24: POSTERIOR LEAD PLACEMENT WITH 10-ELECTRODE CABLE.....		53
FIGURE 25: RIGHT SIDE LEAD PLACEMENT WITH 10-ELECTRODE CABLE		53
FIGURE 26: PEDIATRIC LEAD PLACEMENT WITH 10-ELECTRODE CABLE		54
FIGURE 27: STANDARD 15-LEAD LEAD PLACEMENT WITH 14-ELECTRODE CABLE		54
FIGURE 28: ADULT 16-LEAD LEAD PLACEMENT WITH 14-ELECTRODE CABLE.....		55
FIGURE 29: POSTERIOR 15-LEAD LEAD PLACEMENT WITH 14-ELECTRODE CABLE		55
FIGURE 30: PEDIATRIC 15-LEAD LEAD PLACEMENT WITH 14-ELECTRODE CABLE		56
FIGURE 31: FRANK XYZ LEAD PLACEMENT WITH 14-ELECTRODE CABLE		56
FIGURE 32: BIPOLAR XYZ LEAD PLACEMENT WITH 14-ELECTRODE CABLE.....		57
FIGURE 33: NEHB LEAD PLACEMENT WITH 14-ELECTRODE CABLE		57
FIGURE 34: DERIVED 12-LEAD ECG LEAD PLACEMENT WITH 5-ELECTRODE CABLE		58
FIGURE 35: RESTING ECG VIEWS AND FILTERS PANEL		61
FIGURE 36: RESTING ECG PATIENT INFORMATION PANEL		62
FIGURE 37: STRESS ECG SCREEN		69
FIGURE 38: STRESS ECG LEAD PLACEMENT WITH 10-ELECTRODE CABLE (AAMI LABELS)		70
FIGURE 39: MAIN STRESS TOOLBAR		72
FIGURE 40: STRESS TEST COMMANDS TOOLBAR		73
FIGURE 41: STRESS ECG VIEWS AND FILTERS PANEL		75
FIGURE 42: STRESS ECG AVERAGE VIEWER SCREEN SETUP MENU		75
FIGURE 43: STRESS ECG POST PROCESSING SCREEN TOOLBAR.....		76
FIGURE 44: PATIENT DATA ENTRY.....		84
FIGURE 45: CHANGE THE EXERCISE PROTOCOL		84
FIGURE 46: PLAYBACK WINDOW.....		85
FIGURE 47: CAREFUSION LAB5 CPET SETTINGS		90
FIGURE 48: LATE POTENTIAL SIGNAL AVERAGING SCREEN.....		97
FIGURE 49: LP SIGNAL AVERAGING LEADS PLACEMENT		99
FIGURE 50: LP SIGNAL AVERAGING REVIEW SCREEN.....		104
FIGURE 51: MONITORING ECG SCREEN		105

FIGURE 52: HEART RATE VARIABILITY SCREEN	111
FIGURE 53: MEASUREMENTS—TABULAR SCREEN.....	116
FIGURE 54: MEASUREMENTS—AVERAGES DISPLAY.....	119
FIGURE 55: MEASUREMENTS—QRS DISPLAY	120
FIGURE 56: TOOLBAR OF AVERAGES/QRS.....	120
FIGURE 57: MEASUREMENTS—CALIPER.....	121
FIGURE 58: TOOLBAR OF CALIPER	121
FIGURE 59: REST REPORT	134
FIGURE 60: STRESS APPLICATIONS - COMPREHENSIVE REPORT	135
FIGURE 61: MONITORING ECG REPORT	136
FIGURE 62: HEART RATE VARIABILITY REPORT.....	137
FIGURE 63: LATE POTENTIAL REPORT.....	138

List of Tables

TABLE 1: ELECTROMAGNETIC EMISSIONS	22
TABLE 2: ELECTROMAGNETIC IMMUNITY	22
TABLE 3: GUIDANCE AND MANUFACTURER’S DECLARATION—ELECTROMAGNETIC IMMUNITY.....	23
TABLE 4: RECOMMENDED SEPARATION DISTANCES	23
TABLE 5: MINIMUM COMPUTER CONFIGURATION.....	27
TABLE 6: PRINTERS INSTALLATION REQUIREMENTS	28
TABLE 7: PROGRAM ICONS.....	29
TABLE 8: OPERATION WITH FUNCTION KEYS	59
TABLE 9: RESTING ECG TOOL BAR COMMANDS	60
TABLE 10: RESTING ECG SETUP OPTIONS	68
TABLE 11: STRESS FUNCTION KEYS.....	71
TABLE 12: STRESS MAIN TOOLBAR AND MENUS	72
TABLE 13: STRESS TEST COMMANDS	74
TABLE 14: POST PROCESSING TOOLBAR AND MENUS	76
TABLE 15: STRESS ECG SETUP OPTIONS	83
TABLE 16: PLAYBACK WINDOW TOOLBAR	85
TABLE 17: TRANSFER FILE FORMAT	88
TABLE 18: CONTROLLED TREADMILLS	95
TABLE 19: CONTROLLED ERGOMETERS	96
TABLE 20: LP SIGNAL AVERAGING FUNCTION KEYS	99
TABLE 21: LP SIGNAL AVERAGING SETUP	101
TABLE 22: LP SIGNAL AVERAGING TOOLBAR AND MENUS	103
TABLE 23: LP SIGNAL AVERAGING NUMERICAL RESULTS.....	104
TABLE 24: MONITORING ECG SETUP OPTIONS	108
TABLE 25: MONITORING ECG TOOLBAR AND MENUS	110
TABLE 26: HRV SCREEN.....	112
TABLE 27: HRV SETUP.....	113
TABLE 28: HRV RESULTS	115
TABLE 29: MEASUREMENTS TOOLBAR AND MENUS	123
TABLE 30: STRESS RAW DATA FILE FORMAT	131
TABLE 31: MONITORING ECG RAW DATA FILE FORMAT	132
TABLE 32: TECHNICAL SPECIFICATIONS	133

INTRODUCTION

Manual Organization

This manual explains in detail how to install and use the PC-ECG 1200.

At the beginning of each application chapter, there is a **Quick Start** section, which is a brief explanation of how to carry out a study, including the keyboard short-cuts for the main functions. If you are familiar with ECG procedures, you can use this **Quick Start** section to get up and running quickly.

The software must be installed before the hardware. See **Software Installation** and **Hardware Installation**.

Document Conventions

Notes and Cautions

Pay particular attention at specific points in a procedure when one of the following messages appears:

	<p>Warnings call attention to possible hazards involving potential damage or injury to persons.</p>
<p>WARNING</p>	





















	<p>Cautions refer to practices necessary to protect against potential damage or loss to equipment. Pay careful attention to instructions.</p>
<p>Caution</p>	

	<p>Notes provide pertinent information to help obtain optimum performance from the software or signify an important step or procedure that requires special attention.</p>
<p>Note</p>	

Abbreviations and Acronyms

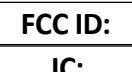
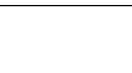
Abbreviation	Meaning
BP	Blood pressure
ECG	Electrocardiogram
HRV	Heart Rate Variability
ID	Identification
LP	Late Potential
LQTS	Long QT Syndrome
METS	Metabolic Stress Estimation
SN	Serial Number
USB	Universal Serial Bus

Equipment Symbols

Symbol	Description
	TYPE BF APPLIED PART
	TYPE CF APPLIED PART
	DEFIBRILLATION-PROOF TYPE BF APPLIED PART
	DEFIBRILLATION-PROOF TYPE CF APPLIED PART
	Class II equipment
	Non-ionizing radiation
	Refer to instruction manual / booklet NOTE On ME EQUIPMENT "Follow instructions for use"
	Complies with the Medical Device Directive of the European Union.
	Caution
	The recorder is not suitable for measurements conducted on children weighing less than 10 kg (formation of loops in the patient cable!).
	IP protection class
	Device Serial Number
	Device Reference Number
	Date of manufacture
	Disposal of the device in accordance with the EU Directive 2002/96/EC (WEEE).
	Use this battery/accumulator rating
	Use this battery/accumulator rating
	Indicates the proper orientation of battery to be installed
	By prescription only. U.S. Federal Law restricts this device to sale on order of a physician only.
	Contains RCM certified RF module
	Contains MIC certified RF module
FCC ID:	Contains FCC certified RF module
IC:	Contains ISED certified RF module

Indications for Use of the PC-ECG 1200

ECG Intended Use

ECG is intended to disclose either normal condition or patterns of arrhythmia, myocardial ischemia, rate abnormalities, or features of prognostic value in adults and pediatric populations in the following cases:

- ◇ Patients with suspected cardiac abnormalities
- ◇ Populations of patients at an age or period in which a routine baseline evaluation of ECG characteristics is desired.

QT Analysis is useful in the assessment of long QT syndrome (LQTS). In some instances, LQTS can be corrected by pharmacological therapy. QT analysis is also used to measure QT dispersion, the difference between maximal and minimal QT values. QT dispersion is a measure of the inhomogeneity of ventricular repolarization. The PC-ECG 1200 contains the Heart Rate Variability software. The clinical significance of Heart Rate Variability measures should be determined by a physician. The PC-ECG 1200 contains the Late Potential software.

The clinical significance of Late Potential measures should be determined by a physician.

Stress Testing Intended Use

Angina pectoris (chest pain) is a clinical syndrome resulting from myocardial ischemia, indicative of reduced blood supply to the cardiac muscle. The electrocardiogram may establish the diagnosis of ischemic heart disease if characteristic changes are present. Stress testing is the most widely used method to decide whether this chest pain is related to myocardial ischemia, and thus to coronary artery disease. In stress testing, the contractile capability of the heart muscle is monitored via ECG during patient exercise. Patients exercise by bicycle, treadmill, or other means, while the ECG is monitored continuously. Exercise loads are determined by predefined protocols. The ECG signals are recorded for the resting, exercise, and recovery phase portions of the exercise protocol. The changes in ECG waveforms are compared to the resting ECG records. Most of the commercial stress test systems control the bicycle or treadmill automatically according to the requirements of the chosen protocol, although this is not essential. ST segment monitoring is intended as an aid in the evaluation of myocardial ischemia in patients with known or suspected coronary artery disease. The ST segment algorithm has been tested for accuracy of the ST segment data, and a database is used as a tool for performance testing.

The significance of the ST segment changes **must** be determined by a physician.

Contraindications for Use and Adverse Effects

The device has no contraindications or adverse effects.

OVERVIEW

Package Contents

The PC-ECG 1200 package contains the following elements:

- Acquisition box – one of the following device models:
 - ◇ PC-ECG 1200S / 1200M
 - ◇ PC-ECG 1200HR
 - ◇ PC-ECG 1200W
 - ◇ Blue-ECG
 - ◇ NR-1207-E / NR-1207-3
- SD memory card (for NR-1207-3 model only)
- Patient cable
- Data USB cable or wireless RF adaptor (for 1200W) or Bluetooth USB transmitter (for Blue-ECG, NR-1207-E and NR-1207-3)
- Software installation media with the PC-ECG 1200 package, including:
 - ◇ Resting ECG
 - ◇ Measurements and Interpretation
 - ◇ Stress ECG
 - ◇ Monitoring ECG
 - ◇ HRV
 - ◇ LP
- Software key (if optional software is included)

Programs

Each program has a specific purpose. The following is a brief description of when to use each one:

Resting ECG	Records and measures short ECG tests on patients in resting position (up to 10 seconds)
Stress ECG	Records and measures ECG tests on patients under stress conditions using a pre-defined test protocol.
Monitoring ECG	Works with an ECG device to record, monitor and save a prolonged ECG test in rest condition
HRV	Tests according to time how patient pulse and heart rate varies with load, medication, etc.
LP	Predicts tendency to ventricular tachycardia

PC-ECG Models

1200S	USB connected ECG acquisition to perform examinations during stress or rest condition.
1200M	USB connected ECG acquisition to perform examinations during rest condition.
1200HR	USB connected ECG data acquisition to perform examinations during stress or rest condition. Stationed on table/cart . In addition to stress and rest testing may be used for advanced
1200W	Wireless RF connected ECG acquisition to perform examinations during stress or rest condition.
Blue-ECG	Wireless Bluetooth connected ECG acquisition to perform examinations during rest condition.
NR-1207-E	Wireless Bluetooth connected ECG acquisition to perform examinations during rest or stress condition. The acquisition module includes the color LCD screen to verify the applied ECG electrodes connection status and to configure the device settings.
NR-1207-3	Wireless Bluetooth connected ECG acquisition with recording function on internal memory card. Dedicated for perform examinations during rest or stress condition. The acquisition module includes the color LCD screen to verify the applied ECG electrodes connection status and to configure the device settings.

Device to Software Option Compatibility

Device/ Acquisition Module	I1, Measures and Expert system	I3 MEANS Interpretation +I1	D1/D3 NEMS ECG Management	S1 Stress	S2 Advanced Stress	M1 Monitoring	L1 Late Potentials	H1 Heart Rate Variability
1200M	+	+	+	-	-	-	-	-
Blue-ECG	+	+	+	-	-	-	-	-
1200HR	+	+	+	+	+	+	+	+
1200S	+	+	+	+	+	-	-	-
1200W	+	+	+	+	+	+	-	-
NR-1207-E	+	+	+	+	+	-	-	-
NR-1207-3	+	+	+	+	+	-	-	-

Safety Warnings and Precautions



WARNING

- **ELECTROSURGERY** – There is a risk of burns and injury to the patient. If an electro surgery device is used, disconnect the ECG cable from the device.
- **CABLES** – Cables present a possible strangulation hazard. To avoid possible strangulation, route all cables away from patient's throat.
- **CONDUCTIVITY** – Electric shock or device malfunction may occur if electrodes contact conductive materials. Keep the conductive parts of lead electrodes and associated parts away from other conductive parts, including earth. Also make sure that no contact to other conductive parts is possible if the electrodes loosen during recording.
- **GENERAL DANGER TO THE PATIENT** – Instructions listed in this manual in no way supersede established medical practices concerning patient care. Perform the established medical practices under all circumstances.
- **EXPLOSION HAZARD**—Do not use in the presence of a flammable anesthetic mixture with air or oxygen or nitrous oxide.
- **DEFIBRILLATION** - Device is defibrillation protected when the original Norav Medical patient cable is used. However, as a safety precaution when possible, remove the electrodes before defibrillation.
- **GENERAL DANGER TO THE PATIENT** - The device is not designed for direct cardiac application.
- **INFECTION RISK** – Reuse of disposable parts that come into contact with patients pose a risk of infecting patients. Do not reuse disposable parts that have had direct contact with the patient, such as ECG electrodes.
- **INTERPRETATION HAZARD** - Computerized interpretation is only significant when used in conjunction with clinical findings. A qualified physician must over read all computer generated tracings.
- **MAGNETIC AND ELECTRICAL INTERFERENCE** - Magnetic and electrical fields are capable of interfering with the proper performance of the device. For this reason make sure that all external devices operated in the vicinity of the device comply with the relevant EMC requirements. X-ray equipment or MRI devices are possible sources of interference as they may emit higher levels of electromagnetic radiation.
- **OPERATOR** - Medical technical equipment such as this system must only be used by qualified and trained personnel.

PATIENT SAFETY

- A patient undergoing a test must be at a distance of at least (relates to the wired models only):
 - ❑ 1.5 meters from the computer, printer and other peripherals, and
 - ❑ 2.5 meters from the ceiling.
- If such conditions cannot be fulfilled, the entire system needs to be connected to the A/C power supply through an Isolation transformer meeting the IEC/EN 60601-1 standard.

OPERATION WITH OTHER DEVICES**WARNING**

- Other devices which are part of the system must meet the requirements of the Standard for Information Technology Equipment (IEC/EN 60950-1) and the Standard for Electrical Medical Devices (IEC/EN 60601-1)
- The personal computer should be approved to the appropriate safety standard for non-medical electrical equipment (IEC/EN 60950-1, or its national variants). Also, the use of additional protective earth ground or an isolation transformer is required for the electric power circuit to which the PC-ECG 1200 System is connected in order to satisfy the IEC/EN 60601-1 safety standard.
- Computers and printers used with Medical Devices should be evaluated for IEC/EN 60950-1, IEC/EN 60601-1 or equivalent safety standard to maintain the safety of Medical Devices.
- Accessory equipment connected to the analogue and digital interfaces must be certified according to the respective IEC/EN standards (e.g. IEC/EN 60950-1 for data processing equipment and IEC/EN 60601-1 for medical equipment). Furthermore, all configurations shall comply with the valid version of the standard IEC/EN 60601-1.
Therefore anybody, who connects additional equipment to the signal input or output connector to configure a medical system, must make sure that it complies with the standard.
- The PC-ECG 1200 controls exercise machines.
Any treadmill used with the PC-ECG 1200 must contain a manual control in order to allow the user to stop the operation of the treadmill in case of emergency.
- When using PC-ECG 1200 in combination with any other equipment, refer to a qualified service technician for correct handling.

**Caution**

- **DAMAGE TO THE DEVICE THROUGH BATTERY LEAKAGE** – Batteries may leak if left in an unused device for prolonged periods. If you intend to store the device for longer than one week, remove the battery from it.
- **CABLE DAMAGE** – Bending or wrapping the cable can damage it. When attaching and affixing the ECG cable, make sure not to bend it excessively. Avoid coiling the ECG cable around the device, as this can damage the cable.
- **DAMAGE TO THE DEVICE** – You may only open the battery compartment of the recorder. Do not use force when handling the recorder.
- **SAFETY ONLY WITH APPROVED ACCESSORIES** – Safe and reliable operation of the device is only possible when using the supplied and approved accessories.
- **DIFFICULTIES FINDING CAUSES FOR MALFUNCTIONS** – To find and repair a malfunction, both device and ECG cable are needed. Remember to include the ECG cable when returning the device for service or repair. (Avoid wrapping the ECG cable around the device, as this can damage the cable.) Always use the same ECG cable with a device. If an institution has several devices and ECG cables, try to ensure that each device is matched with a specific ECG cable. In this way, cable or recorder failures can be isolated and eliminated faster. In the event of apparent changes in the performance of the device, discontinue use immediately. Do not resume use until the device is approved by the manufacturer or by a representative of the manufacturer.
- **DAMAGE TO DEVICE AND ACCESSORIES** – Unauthorized personnel do not have the proper training to repair the device. Repairs carried out by unauthorized personnel could result in damage to the device or accessories. Send the device for inspection to an authorized facility if you find or even suspect a malfunction. Please add a detailed description of the observed malfunction.
- **DAMAGE TO THE DEVICE** – Take care to prevent chemicals\liquids from entering the connectors or internal part of the device.



Caution

- **Pacemaker** - It is recommended that a minimum separation of 15 cm (6 inches) be maintained between the wireless models Blue-ECG/NR-1207-E/NR-1207-3/1200W and a pacemaker to avoid potential interference with pacemaker. Some studies have shown that wireless devices might interfere with implanted cardiac pacemakers if used within eight inches of the pacemaker. Pacemaker users may want to avoid placing or using a wireless device this close to their pacemaker. Patients with a pacemaker:
 - Should always keep the wireless Blue-ECG/NR-1207-E/NR-1207-3 unit at least 30 cm from their pacemaker when the ECG unit is turned on.
 - Should not carry the Blue-ECG/NR-1207-E/NR-1207-3 in their breast pocket.

If you have any reason to suspect that interference is taking place, turn off the ECG immediately.



Caution

- If audio is playing on the PC, the ECG shows interference. Do not run an audio CD on the PC while running an ECG test via the USB connection.
- Operate the unit only at clinics and hospitals. Do not use at home.



Caution

- **Power supply** - The PC-ECG 1200 uses mains power supply (unless connected via the USB port). The wireless PC-ECG 1200W transmitter uses battery power supply. PC-ECG 1200WR receiver uses Power supply via USB port. The wireless Blue-ECG, NR-1207-E and NR-1207-3 uses battery power supply.

Use only the recommended battery type as instructed in the technical specifications to operate the 1200W, Blue-ECG, NR-1207-E and NR-1207-3 (AA size alkaline or NiMH rechargeable batteries).

Do not use batteries with expired dates.

Remove batteries from the unit (1200W/Blue-ECG/NR-1207-E/NR-1207-3) when it is not in use.

- For 1200W - Use only while device is worn on patient with its strap.
- Use only with battery compartment closed.

**Note**

The device (1200W/Blue-ECG/NR-1207-E/ NR-1207-3) complies with Part 15 of the FCC Rules.

Operation is subject to the following two conditions:

- (1) This device may not cause harmful interference and
- (2) This device must accept any interference received, including interference that may cause undesired operation.

**Note**

The manufacturer is not responsible for any Radio or TV interference caused by unauthorized modifications to this equipment. Such modifications could void the user's authority to operate the equipment.

**Note**

Install hardware only after software installation.

Classification Of The Equipment

- According to the type of protection against electric shock:
CLASS II
or
INTERNALLY POWERED EQUIPMENT (*1200W, Blue-ECG, NR-1207-E and NR-1207-3*)
- According to the degree of protection against electric shock:
TYPE CF APPLIED PART
or
TYPE BF APPLIED PART (*NR-1207-E and NR-1207-3*)
- According to the degree of protection against ingress of water: ORDINARY EQUIPMENT
or
IPX2 (*NR-1207-E and NR-1207-3*)
- According to the degree of safety of application in the presence of a flammable anaesthetic mixture with air or with oxygen or nitrous oxide:
EQUIPMENT NOT SUITABLE FOR USE IN THE PRESENCE OF A FLAMMABLE ANAESTHETIC MIXTURE WITH AIR OR WITH OXYGEN OR NITROUS OXIDE.
- According to the mode of operation:
CONTINUOUS OPERATION

EMC Specifications according to IEC 60601-1-2

Emissions Test	Compliance	Electromagnetic Environment—Guidance
<i>This device is intended for use in the electromagnetic environment specified below. The customer and/or user of this device should ensure that it is used in such an environment.</i>		
RF Emissions CISPR 11	Group 2	This device must emit electromagnetic energy in order to perform its intended function. Nearby electronic equipment may be affected.
RF Emissions CISPR 11	Class B	This device is suitable for use in all establishments, including domestic and those directly connected to the public low-voltage power supply network that supplies buildings used for domestic purposes.
Harmonic Emissions IEC 61000-3-2	N/A < 75W	
Voltage Fluctuations/Flicker Emissions IEC 61000-3-3	Complies	

Table 1: Electromagnetic Emissions

Immunity Test	IEC 60601 Test Level	Compliance Level	Electromagnetic Environment—Guidance
<i>This device is intended for use in the electromagnetic environment specified below. The customer and/or user of this device should ensure that it is used in such an environment.</i>			
Electrostatic Discharge (ESD) IEC 61000-4-2	±6 kV contact ±8 kV air	±6 kV contact ±8 kV air	Floors should be wood, concrete, or ceramic tile. If floors are covered with synthetic material, relative humidity should be at least 30%.
Electrical Fast Transient/Burst IEC 61000-4-4	±2 kV for power supply lines ±1 kV for input/output lines	±2 kV for power supply lines ±1 kV for input/output lines	Mains power quality should be that of a typical commercial or hospital environment.
Surge IEC 61000-4-5	±1 kV differential mode ±2 kV common mode	±1 kV differential mode ±2 kV common mode	Mains power quality should be that of a typical commercial or hospital environment.
Voltage dips, short interruptions, and voltage variations on power supply input lines IEC 61000-4-11	±5% U _T (>95% dip in U _T) for 0.5 cycle ±40% U _T (60% dip in U _T) for 5 cycles ±70% U _T (30% dip in U _T) for 25 cycles <5% U _T (>95% dip in U _T) for 5 sec.	±5% U _T (>95% dip in U _T) for 0.5 cycle ±40% U _T (60% dip in U _T) for 5 cycles ±70% U _T (30% dip in U _T) for 25 cycles <5% U _T (>95% dip in U _T) for 5 sec.	Mains power quality should be that of a typical commercial or hospital environment.
Power Frequency (50/60 Hz) Magnetic Field IEC 61000-4-8	3 A/m	3 A/m	Power frequency magnetic fields should be at levels characteristic of a typical location in a typical commercial or hospital environment.
NOTE: U _T is the AC mains voltage before application of the test level.			

Table 2: Electromagnetic Immunity

Immunity Test	IEC 60601 Test Level	Compliance Level	Electromagnetic Environment—Guidance
<i>This device is intended for use in the electromagnetic environment specified below. The customer and/or user of this device should ensure that it is used in such an environment.</i>			
Portable and mobile RF communications equipment should be used no closer to any part of the device, including cables, than the recommended separation distance calculated from the equation applicable to the frequency of the transmitter.			
Conducted RF IEC 61000-4-6 Radiated RF IEC 61000-4-3	3 Vrms 150 kHz to 80 MHz 3 V/m 80 MHz to 2.5 GHz	3 Vrms 3 V/m	Recommended Separation Distance $d = 1.17 \sqrt{P}$ $d = 1.17 \sqrt{P}$ 80 MHz to 800 MHz $d = 2.33 \sqrt{P}$ 800 MHz to 2.5 GHz where P is the maximum output power rating of the transmitter in watts (W) according to the transmitter manufacturer and d is the recommended separation distance in meters (m). Field strengths from fixed RF transmitters, as determined by an electromagnetic site survey ^a , should be less than the compliance level in each frequency range ^b . Interference may occur in the vicinity of equipment marked with the following symbol: 

- a. Field strengths from fixed transmitters, such as base stations for radio (cellular/cordless) telephones and land mobile radios, amateur radio, AM and FM radio broadcast and TV broadcast cannot be predicted theoretically with accuracy. To assess the electromagnetic environment due to fixed RF transmitters, an electromagnetic site survey should be considered. If the measured field strength in the location in which the device is used exceeds the applicable RF compliance level above, the device should be observed to verify normal operation. If abnormal performance is observed, additional measures may be necessary, such as reorienting or relocating the device
- b. Over the frequency range 150 kHz to 80 MHz, field strengths should be less than [3] V/m.

NOTES:

- At 80 MHz and 800 MHz, the higher frequency range applies.
- These guidelines may not apply in all situations. Electromagnetic propagation is affected by absorption and reflection from structures, objects, and people.

Table 3: Guidance and Manufacturer’s Declaration—Electromagnetic Immunity

The following table details the recommended separation distances between portable and mobile RF communications equipment and NR recorder.

<i>This device is intended for use in an electromagnetic environment in which radiated RF disturbances are controlled. Users of this device can help prevent electromagnetic interference by maintaining a minimum distance between portable and mobile RF communication equipment (transmitters) and the device as recommended below, according to maximum output power of the communications equipment.</i>			
Rated Maximum Output Power of Transmitter	Separation Distance According to Frequency of Transmitter(m)		
	150 kHz to 80 MHz $d = 1.17 \sqrt{P}$	80 MHz to 800 MHz $d = 1.17 \sqrt{P}$	800 MHz to 2.5 GHz $d = 2.33 \sqrt{P}$
W			
0.01	0.12	0.12	0.23
0.1	0.37	0.37	0.74
1	1.2	1.2	2.3
10	3.7	3.7	7.4
100	12	12	23

For transmitters rated at a maximum output power not listed above, the recommended separation distance d in meters (m) can be estimated using the equation applicable to the frequency of the transmitter, where P is the maximum output power rating of the transmitter in watts (W) according to the transmitter manufacturer.

NOTES:

- At 80 MHz and 800 MHz, the higher frequency range applies.
- These guidelines may not apply in all situations. Electromagnetic propagation is affected by absorption and reflection from structures, objects, and people.

Table 4: Recommended Separation Distances

MAINTENANCE



Cautions

- The device is not waterproof. Never immerse any part of the equipment including device, cables or leadwires in any liquid. Maintain in a dry place.
- ELECTRICAL HAZARD — Improper handling during inspection or cleaning could result in electrical shock. To avoid potential shock, observe the following guidelines at all times:
 - Before inspecting or cleaning the system, turn it off, unplug it from AC power, and remove the battery.
 - Do not pour or spray any liquid directly on cables or leadwires or permit fluid to seep into connections or openings.
 - Never use conductive solutions, solutions that contain chlorides, wax, or wax compounds to clean device, cables or leadwires.
 - Never autoclave or steam clean cables or leadwires.
 - Never use solutions or products that contain the following:
 - Any type of Ammonium Chloride such as, but not limited to:
 - Dimethyl Benzyl Ammonium Chloride
 - Quaternary Ammonium Chloride solutions
 - Abrasive cleaners or solvents of any kind
 - Acetone
 - Ketone
 - Betadine
 - Sodium salts
- Cleaning products to be avoided, including but not limited to:
 - Sani-Cloth® Wipes
 - Ascepti® Wipes
 - HB Quat
 - Clorox® Wipes (they do not contain bleach).
 - Over-the-counter detergents (e.g. Fantastic®, Tilex®, etc.).
 - Products that contain active ingredients similar to above listed
- Improper cleaning products and processes impact/results:
 - Product discoloration
 - Metal part corrosion
 - Brittle wires
 - Brittle and breaking connectors
 - Reduced cables and leadwires life
 - Unit malfunction
 - Void warranty

Perform a visual inspection daily, preferably before the equipment's first use each day.

During the inspection, verify that the device meets the following minimum conditions:

- The device case is free of cracks and other damage.
- All plugs, cords, cables, and connectors are free of kinks, frays, and other damage.
- All cords and connectors are securely seated.
- All keys and controls operate properly.

If you notice any items that need repair, contact an authorized service representative to make the repairs. Discontinue using the device until the appropriate repairs can be made.



Note

If liquid penetrates the device, i.e., during cleaning or operation, this may interfere with correct functioning. Switch the device OFF and remove the battery. Leave the device in a warm, dry room with the battery door open for 48 hours. If the functioning is still affected, contact the contact customer support.

Device Cleaning and Disinfecting

Clean the exterior surface of the device monthly, or more frequently if needed.

USE the following materials to clean the device:

- Neutral/mild pH enzymatic detergent
- Clean, soft cloth
- Water

DO NOT USE any of the following materials to clean the device, because their use may damage equipment surfaces.

- Organic solvents
- Ammonia-based solvents
- Abrasive cleaning agents
- Virex
- Sani-Master

Manual Cleaning procedure

Use the following procedure to clean the surfaces of the device.

- 1) Wear disposable gloves.
- 2) Use a soft non-abrasive damp cloth with tap water, wipe the device for at least 30 sec., repeat as necessary or until there is no residues of soil and dirt on the device.
- 3) Prepare a neutral/mild pH enzymatic detergent, according to manufacturer's instructions (in the lowest recommended concentrations).
- 4) Immerse the soft non-abrasive damp cloth with the prepared detergent, then wipe the device for at least 30 sec., Repeat as necessary or until there is no residues of soil and dirt on the device.
- 5) Place the device to dry for at least 10 minutes.

Low level Disinfection procedure

Following cleaning procedure, perform the disinfection procedures as following.

- 1) Use an Isopropanol 70% wipes to disinfect the device for at least 3 minutes. Repeat as necessary.
- 2) Place the device to dry for at least 10 minutes.

ECG Cables and Leadwires Cleaning and Disinfecting

- Remove cables and leadwires from the Norav device before cleaning.
- Use care in cleaning leadwires to prevent pulling the long wires from the connector ends. Metal connections can be pulled away from the connectors.
- For general cleaning of cables and leadwires, wipe using a lightly moistened cloth with a mild soap and water solution. Then wipe and air dry.
- For disinfecting the cables and leadwires, wipe exterior with a soft lint-free cloth, using the following solution as recommended in the APIC Guidelines for Selection and Use of Disinfectants (1996):
 - Sodium hypochlorite (5.2% household bleach) minimum 1:500 dilution (minimum 100 ppm free chlorine) and maximum 1:10 dilution.
 - Any sodium hypochlorite wipe product that meets the above guidelines of can be used.



Note

Wring excess disinfectant from wipe before using

**Note**

Any contact of disinfectant solutions with metal parts may cause corrosion.

- Do NOT immerse either end of a cable or leadwire connector. Immersing or “soaking” the connector ends may corrode metal contact ends and affect signal quality.
- Wipe off cleaning solutions with a clean, lightly moistened cloth.
- Dry thoroughly with a dry lint-free cloth and let air dry for at least 30 minutes.

**Note**

Drying times may vary based on the environmental conditions.

- Take care not to let fluid “pool” around connection pins. If this should happen, blot dry with a soft, lint-free cloth.
- DO NOT use excessive drying techniques, such as oven, forced heat or sun drying.

Sterilization

**Note**

EtO sterilization is NOT RECOMMENDED, but may be required for cables and leadwires. Frequent sterilization will reduce the useful life of cables and leadwires.

Sterilize with ethylene oxide gas (EtO) at a maximum temperature of 50° C/ 122° F. After EtO sterilization, follow the recommendations from the sterilizer manufacturer for required aeration.

Calibration

The device does not need any calibration.

SOFTWARE INSTALLATION

System Requirements and Prerequisites



Note:

Install the software before installing the hardware. If the device is connected to the PC, disconnect the device before installing the software.



Note

Stress application with real-time printout is resource intensive. To optimize performance, we recommend that you disable “Start Up” programs to free system resources. For instructions, see Windows help.



Note

The PC should not be set up to work under saving power conditions. Do not enable PC sleep mode (standby), hibernate, or turning off the hard disk while running an ECG test.

PC Minimum Configuration

Application		CPU performance	RAM amount (GB)	Disk free space (GB)	Free USB Ports (*a)
Resting ECG		Intel i3 or similar	2.0	2	2 (*b)
Monitoring ECG		Intel i3 or similar	2.0	20	2 (*b)
LP		Intel i3 or similar	2.0	2	2 (*b)
HRV		Intel i3 or same	2.0	2	2 (*b)
Stress ECG	ECG Device only	Intel i5 or similar	4.0	20	2 (*b)
	Treadmill/Ergometer				+1(*c)
	Blood pressure monitor				+1(*c)
	MP 200 Thermal printer				+1(*d)

Table 5: Minimum Computer Configuration

*a – a port for a standard local printer or for a LAN printer not included in the required free port calculations

*b – old model 1200M/S device might require a 1200USB adapter

*c – use a USB-to-COM standard adapter or a direct RS232 port instead of the USB port

*d – use a USB-to-LPT adapter or direct to the LPT port instead of USB port



Note

The computer has to meet the requirements of the Standard for Information Technology Equipment (IEC/EN 60950-1)

Printers

Application	Technology	RAM Memory (MB)	Driver
Resting ECG	LASER/INK	2	Vendor / MS
Monitoring ECG	LASER/INK	2	Vendor / MS
LP	LASER/INK	2	Vendor / MS
HRV	LASER/INK	2	Vendor / MS
Stress ECG	Fast LASER	8	Vendor / MS

Table 6: Printers Installation Requirements

Thermal Printer

The thermal printer driver is installed separately from the PC-ECG 1200 program.

A thermal printer can be supplied by Norav (MP200, 8 inch). This printer requires a dongle with the P1 license permission.

The MP200 driver is available on the PC-ECG 1200 installation media.

Installing or Updating PC-ECG 1200 Software

The software package works under Microsoft Windows operating systems:
Windows 8/10/11.

To Install PC-ECG 1200

- Insert the installation media in the CD drive or to the USB slot. If installation will not start automatically run the  Setup program from the installation disk root.
- Follow the instructions on-screen.
- As part of the installation procedure, you have to choose the software access security level. Available options are **Basic** or **Elevated** security.
 - Installed with *Basic* security level- no user password will be required on ECG application start.
 - If *Elevated* security was selected during the software installation- the operator will be forced to enter username and password on ECG application start. Required username is **ecguser**, and password is **login**. Additionally, there is a different password for configuration setup panel. The configuration setup protection password is **norav** .

After you have completed installation, a group icon called PC-ECG 1200 is added to the desktop. Double-click the group icon to display the following program icons.





Icon	Explanation
	Heart Rate Variability
	Late Potential Signal Averaging
	Monitoring ECG
	Resting ECG
	Stress ECG

Table 7: Program Icons

Resting ECG is the basic software package. It does not require a software key.
The following are optional and require software keys:

- ◇ Measurement and interpretation functions for Resting ECG
- ◇ Heart Rate Variability
- ◇ Late Potential
- ◇ Monitoring ECG
- ◇ Stress ECG

You can activate optional packages that have no key by selecting **Simulator** in Setup.

If you have purchased the **S2 Advanced Stress** option and would like to use remote viewing, install the **Remote View** program from the **Remote View** directory on the CD. This program enables a remote viewer for an ECG study. The image is displayed in JPEG format.

To Uninstall PC-ECG 1200

New Version Replacing Old Version

There is no need to remove the previous installation. The existing setup will remain for the new version.

If the new software version does not operate properly, uninstall the old installation and then repeat the installation of the new version again.

Old Version Replacing New Version

Uninstall the existing version as follows:

My Computer → Control Panel → Add/Remove Programs → PC-ECG 1200 → Add/Remove → OK.

To Free Disk Space and Ensure Smooth Operation

Windows provides utilities to delete superfluous files, and to defragment the disk. Refer to Windows help for instructions on using Disk Cleanup and Defragment.

Backing up and Restoring Setups and Protocols

When you reinstall or upgrade PC-ECG 1200, the program overwrites your existing configurations and protocols.

To save the configuration data for stress application, follow these procedures.

To Save the Software Setup Configuration

- Start the Stress ECG application.
- Click **View\Save Setup**.

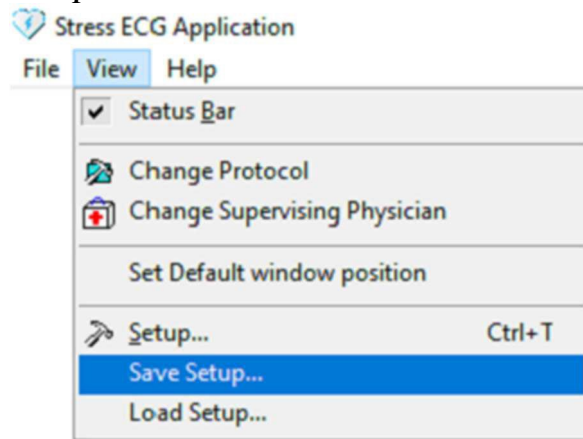

Figure 1: Saving the Software Setup Configuration

- Name the file. Provide a location in which to save the file and Click **OK**.

To Load the Software Setup Configuration

- Start the Stress ECG application.
- Click **View\Load Setup**.
- Click **Browse** and find the location in which the file is saved.
- Select the file (with the name you gave it and the suffix 'INI') and click **OK**.

To Save Stress Protocols

- Create a new directory in your computer Documents, with a name like **PcBackup**.
- Copy file **StWorked.mdb** from the PC-ECG settings folder (normally in the C:\ProgramData\Norav Medical\Settings\).
- Paste it into a backup directory (e.g., Documents\PcBackup).

To Load Stress Protocols

- Copy the file **StWorked.mdb** from the directory where you saved it (e.g., Documents\PcBackup).
- Paste it into the PC-ECG settings folder (normally it is in the C:\ProgramData\Norav Medical\Settings\).
- A window is displayed, asking you if you would like to replace the existing file. Click **Yes**.

To Set Preferences

- After installing the PC-ECG 1200 package, and prior to operation, click **Setup** to tailor your preferences.
- Begin with **Environment**, which configures the hardware.
- Continue with the other tabs in any order.

HARDWARE INSTALLATION

Installing Model 1200S and Model 1200M

The PC-ECG 1200S or PC-ECG 1200M kit contains the following items:

- ◇ Acquisition box
- ◇ Patient cable
- ◇ USB cable
- ◇ PC-ECG 1200 software installation package on CD or USB flash drive.
- ◇ Software license key (if optional software is included)



Figure 2: PC-ECG 1200S / PC-ECG 1200M

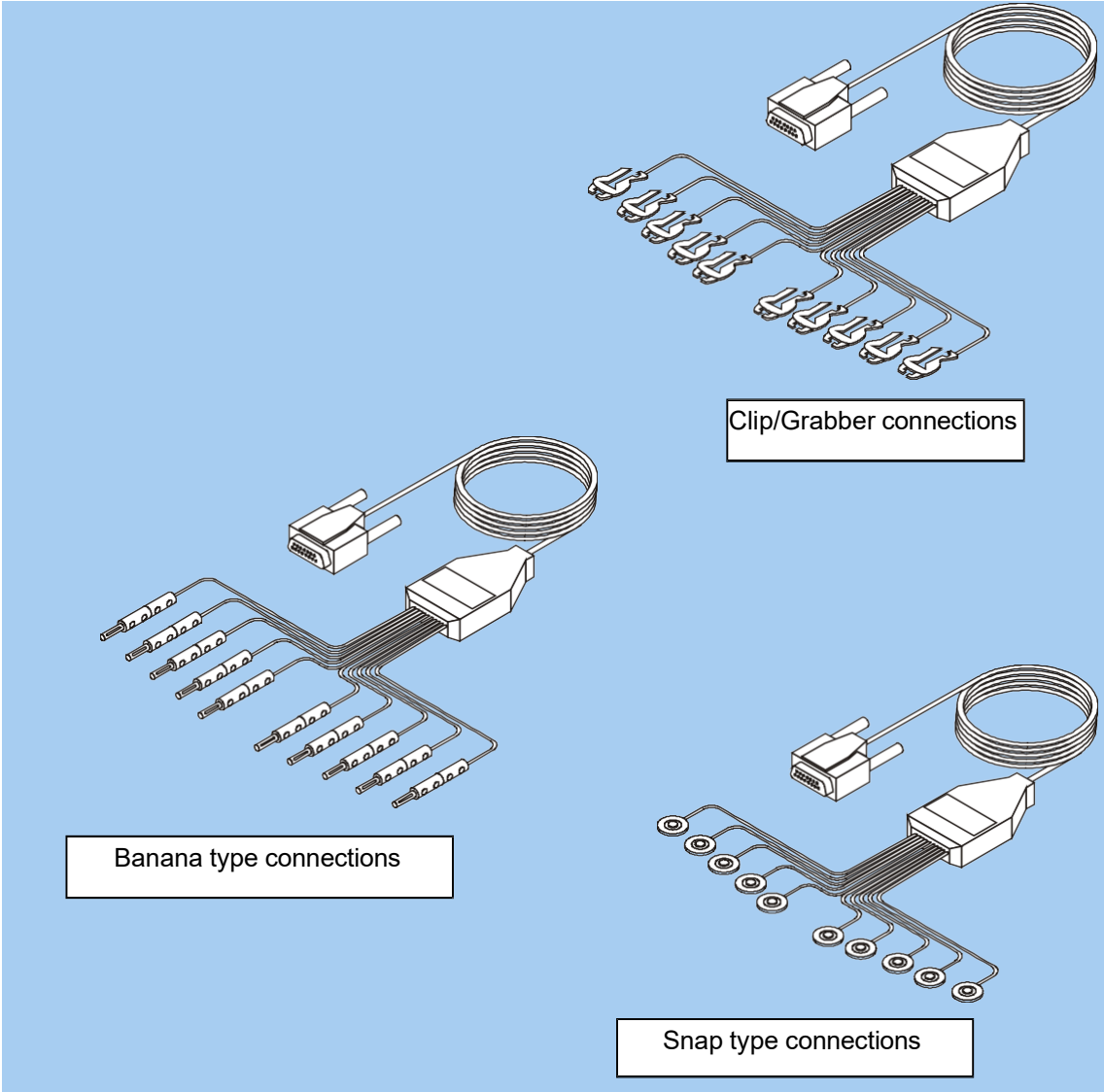

Figure 3: Patient Cable

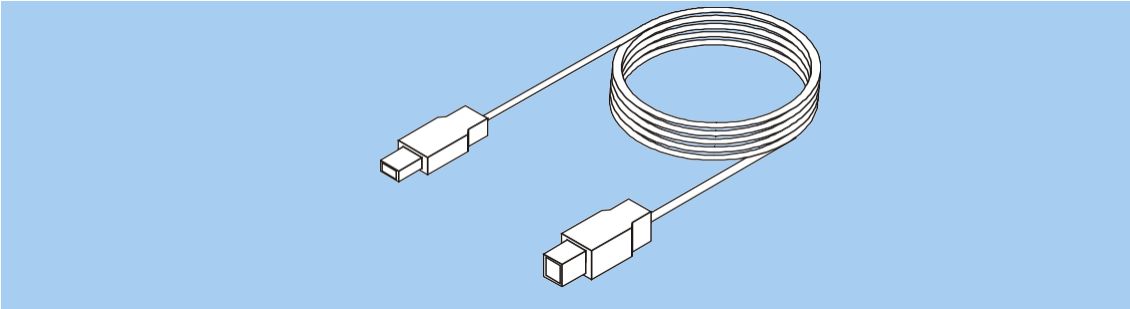

Figure 4: USB Cable

To Connect Via USB

- Connect the A-type connector of the USB cable to the PC.
- Connect the B-type connector of the USB cable to the input of the 1200M/1200S unit.
- A wizard for installing new hardware driver might appear. Wait until the driver is installed and the green light is illuminated on the 1200M/1200S unit.
- Verify that the ON light is illuminated on your 1200M/1200S device.
- Connect the patient cable to the 15-pin plug of the 1200M/1200S device side.
- If the optional software key is included, connect it to computer.
- If a printer is connected, plug the printer cable into the key.
- Connect the electrode leads to the patient, starting with right leg.

To Verify the Connections

- Run the Resting ECG application.
- Press **F1** for a new test.
- Insert patient details in the dialog and then click **OK**.
- Verify that traces are acquired and displayed on the screen.

Installing Model 1200HR

The PC-ECG 1200HR kit contains the following items:

- ◇ Acquisition box
- ◇ Patient leads
- ◇ Built-in USB cable
- ◇ PC-ECG 1200 software installation package on CD or USB flash drive.
- ◇ Software license key (if optional software is included).

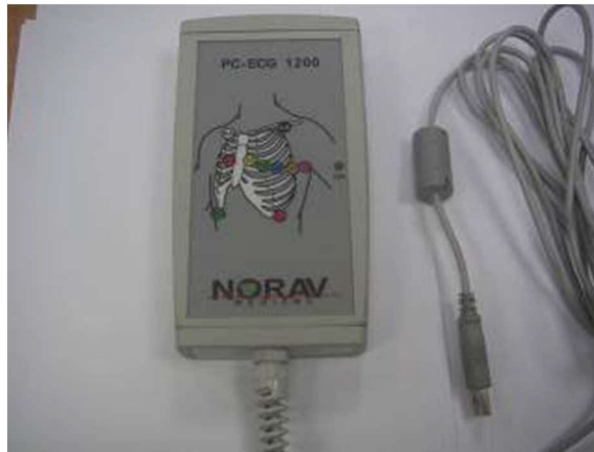

Figure 5: PC-ECG 1200HR (with built-in USB cable)

To Connect Via USB

- Connect the USB A-type connector of the USB cable to the PC.
- If the optional software key is included, connect it to computer.
- Wait until the driver is installed and the green light is illuminated on the 1200HR.
- Connect the patient cable to the 15-pin plug of the PC-ECG 1200HR.

To Connect to the Patient and the Computer

- Verify that the indication LED is on on the PC-ECG 1200HR front.
- Connect the electrode leads to the patient, starting with right leg.

To Verify the Connections

- Run the Resting ECG application.
- Press **F1** keyboard key for a new test.
- Insert patient details in the dialog and then click **OK**.
- Verify that traces are acquired and displayed on the screen.

Installing Model 1200W

The PC-ECG 1200W kit contains the following items:

- ◇ Acquisition box
- ◇ Patient leads
- ◇ USB cable
- ◇ Antenna
- ◇ 1200WR receiver
- ◇ PC-ECG 1200 software installation package on CD or USB flash drive.
- ◇ Software license key (if optional software is included).



Figure 6: PC-ECG 1200W

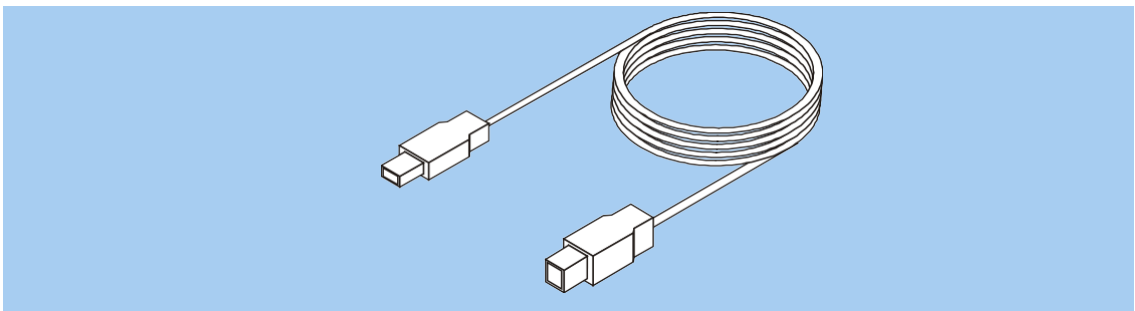
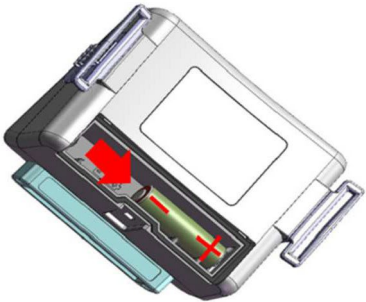

Figure 7: USB Cable

1200W Battery Installation



Step 1

Insert the first battery and slide it to the right

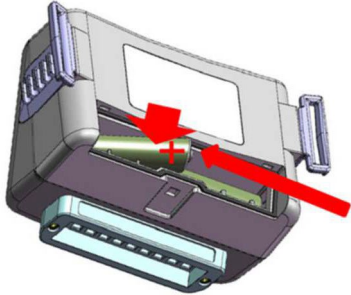

Step 2

Insert the second battery and push it to the left and down with the same movement



Step 3

Place the battery cover



Step 4

Push the battery cover down until get click

Figure 8: 1200W battery installation

To Connect Via USB

- Connect Antenna to the connector on 1200WR Receiver.
- Connect the A-type connector of the USB cable to the PC.
- Connect the B-type connector of USB cable to the USB port of the 1200WR Receiver.
- Wait until the driver is installed and the green light is illuminated on the 1200WR Receiver.
- Plug the 10 patient leads to the PC-ECG 1200W according to the labels on the lead sockets.
- Insert 2 x AA alkaline or NiMH rechargeable batteries into the battery compartment of the PC-ECG 1200W unit.
- Switch on the PC-ECG 1200W and verify that the ON light is illuminated.
- If the optional software key is included, connect it to the computer.
- Connect the external hardware via the appropriate cable(s) to one or more BNC connectors on the 1200W Receiver (valid for **S2 Advanced Stress** option): TTL Trigger out for blood pressure monitor synchronization, couple analog outputs using the ECG lead, heart rate or for drive of the analog controlled treadmill/ergometer.

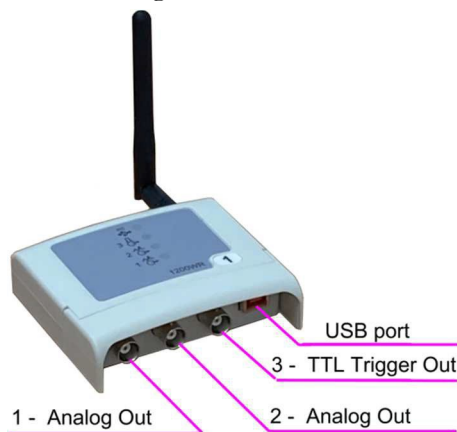

Figure 9: 1200WR Receiver

To Verify the Connections

- Fasten the PC-ECG 1200W device to the patient body with a belt.
- Connect the electrode leads to the patient, starting with right leg.
- Run the Resting ECG application.
- Press **F1** keyboard key for a new test.
- Insert patient details in the dialog and then click **OK**.
- Verify that traces are acquired and displayed on the screen.

Installing Model Blue-ECG

The PC-ECG 1200 Blue-ECG kit contains the following items:

- ◇ Acquisition box
- ◇ Patient cable
- ◇ Two AA size alkaline batteries (optional)
- ◇ Bluetooth USB adaptor
- ◇ USB extension cable
- ◇ PC-ECG 1200 software installation package on CD or USB flash drive.
- ◇ Software license key (if optional software is included).

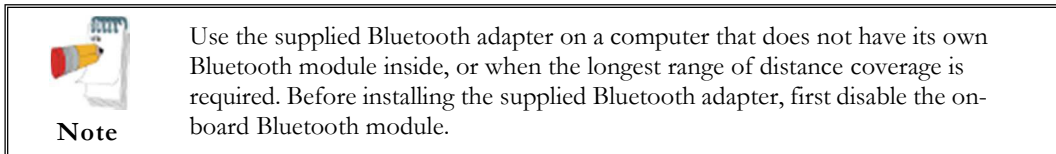

Figure 10: PC-ECG 1200 Blue-ECG

To install the Blue-ECG device

Install Bluetooth adapter

If PC doesn't have built-in Bluetooth device connect the Bluetooth adapter to computer's USB port and check that it installed correctly.



Connect the Bluetooth adapter to the USB port. The new hardware is identified. After the driver is installed, a Bluetooth icon appears on the system tray.



Figure 11: Bluetooth Icon on system tray

Power up Blue-ECG device

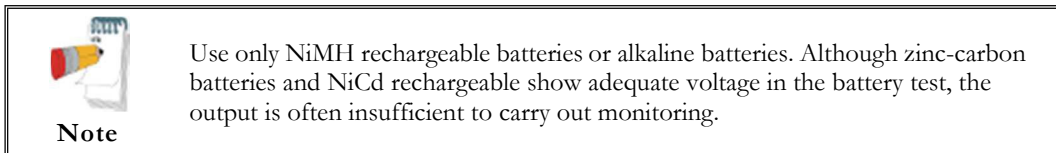

- Plug the patient cable to the round connector on the top of the Blue-ECG device
- Insert the batteries according to the polarity of its terminals (“+”, “-”).
- Push the button on the front of the Blue-ECG device to switch it ON.

Add the Blue-ECG to Bluetooth devices list

- Double click on the Bluetooth icon on the system tray. Click **Add Bluetooth or other device** then select **Bluetooth**.
- Select the “ECGBT8-XXX” device name.
- Enter **12345** as the passkey and click **Connect**.
- After device is paired click **Done**.



Install software license key (optional)

Connect the HASP dongle to the USB port. The new hardware is identified. After the driver is installed, a red indication light appears on the HASP dongle.

Register the Blue-ECG device in the Resting ECG software application

- Run the Resting ECG software application from the PC-ECG 1200 desktop folder.
- Click the **Setup** main menu button.
- Open the **Environment** folder then select **Bluetooth** device option.
- Click **OK** button to apply changes then close the Resting ECG application.

Verify connections

- Run the Resting ECG application again and verify the  icon appears on the right side.
- Initiate new test by clicking the  button or by pressing the **F1** keyboard key.
- Verify that traces are acquired and displayed on the screen and then click .

Installing Models NR-1207-E and NR-1207-3

The PC-ECG NR-1207-E kit contains the following items:

- ◇ Acquisition box
- ◇ Patient cable
- ◇ AA size alkaline battery (optional)
- ◇ SD memory card (for NR-1207-3 model only).
- ◇ Bluetooth USB adaptor
- ◇ USB extension cable
- ◇ PC-ECG 1200 software installation package on CD or USB flash drive.
- ◇ Software license key (if optional software is included).



Figure 12: PC-ECG NR-1207-E/NR-1207-3

Patient Cable Connection



Connecting:

Insert the ECG cable connector into the slot on top of the NR-1207-E or NR-1207-3 unit.

Make sure to insert the cable connector until both of two latches of the cable connector are locked on the unit.

Disconnecting:

Remove the ECG cable connector by squeezing the two side latches on the head of the cable connector and pulling away from the connector slot.

Figure 13: NR-1207-E / NR-1207-3 Patient Cable Connection

Memory Card Insertion

(For NR-1207-3 model only)



Open the battery compartment cover by moving left and up the cover latch.



Validate that there is no battery in the battery compartment. The battery must be removed prior to inserting or removing the memory card.

Push the memory card into the slot until it locks in place. To remove the memory card, push the card 1-2 mm into the slot to release the locking catch.

Figure 14: NR-1207-3 Memory Card Insertion

Battery Installation



Open the battery compartment cover by moving left and up the cover latch.



Insert a fresh AA battery. First insert from the negative terminal.
Ensure that the battery's removal ribbon goes behind the battery.



Close battery compartment cover and press on it until latches into the base part.
Make sure that the ribbon is completely hidden under the cover.

Figure 15: NR-1207-E / NR-1207-3 battery installation

To install the NR-1207-E or NR-1207-3 device

Install Bluetooth adapter

If PC doesn't have built-in Bluetooth device connect the Bluetooth adapter to computer's USB port and check that it installed correctly.

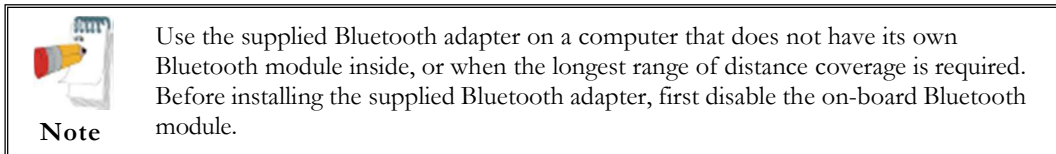

Connect the Bluetooth adapter to the USB port. The new hardware is identified. After the driver is installed, a Bluetooth icon appears on the system tray.



Figure 16: Bluetooth Icon on system tray

Power up the NR-1207-E / NR-1207-3 device

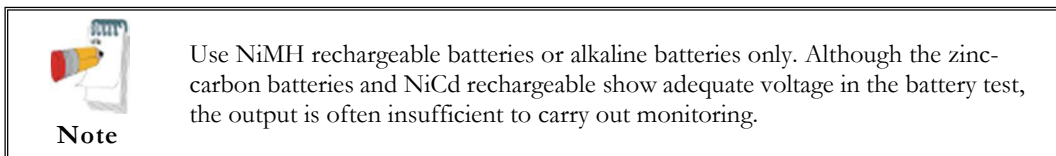

- Plug the patient cable to the connector on the NR-1207-E / NR-1207-3 top.
- Insert the battery according to the polarity of its terminals (“+”, “-”).
- Push the button on the NR-1207-E / NR-1207-3 front to switch it ON.

Add the NR-1207-E / NR-1207-3 to Bluetooth devices list

- Double click on the Bluetooth icon on the system tray. Click **Add Bluetooth or other device** then select **Bluetooth**.
- Select the device name, which can be “NR-1207-E-xxxx”, “NR-1207-3” or for some modifications it could be “NR Recorder”.
- Enter **12345** as the passkey and click **Connect**.
- After device is paired click **Done**.



Install the software license key (optional)

Connect the HASP dongle to the USB port. The new hardware is identified. After the driver is installed, a red indication light appears on the HASP dongle.

Register the NR-1207-E / NR-1207-3 device in the Resting ECG software application

- Run the Resting ECG software application from the PC-ECG 1200 desktop folder.
- Click the **Setup** main menu button.
- Open the **Environment** folder then select **Bluetooth** device option.
- Click **OK** button to apply changes then close the Resting ECG application.

Verify connections

- Run the Resting ECG application again and verify the  icon appears on the right side.
- Initiate new test by clicking the  button or by pressing the **F1** keyboard key.
- Verify that traces are acquired and displayed on the screen and then click .

Connecting an Exercise Device

You can connect a PC-controlled treadmill and/or ergometer to the computer via the USB, RS232 or Analog control interface.

To Connect an RS232 Controlled Treadmill/Ergometer

- Connect the Treadmill/Ergometer by the RS232 cable to free COM port on the computer.
- Configure the Stress ECG software (in setup **Environment** tab):
 - Select the connected COM port number.
 - Select the exercise device communication protocol in the **Type** list.

To Connect an USB Controlled Treadmill/Ergometer

- Connect the Treadmill/Ergometer by the USB cable to free USB port on the computer. The computer will automatically generate a virtual COM port for this connection.
- Configure the Stress ECG software (in setup **Environment** tab):
 - Select the connected COM port number.
 - Select the exercise device communication protocol in the **Type** list.

To Connect an Analog Controlled Treadmill/Ergometer

For 1200W model with the 1200WR receiver having 3x BNC output connectors

- Connect the analog controlled Treadmill/Ergometer cables to the **Analog Out 1** and **Analog Out 2** output connectors on the 1200WR box.
- Configure the Stress ECG software (in setup **Environment/Advance** tab):
 - for Treadmill
 - in **Analog Out 1** select the **Analog Control** and then choose the **Speed** option. Adjust the control voltage range in **Settings**.
 - in **Analog Out 2** select the **Analog Control** and then choose the **Grade** option. Adjust the control voltage range in **Settings**.
 - for Ergometer
 - in **Analog Out 1** select the **Analog Control** and then choose the **Watts** option. Adjust the control voltage range in **Settings**.

For control by the D/A convertor PCI board

- Connect the Treadmill/Ergometer by the dedicated cable to the D/A board output.
- Configure the Stress ECG software (in setup **Environment/Advance** tab):
 - in **Cards** panel select the **Analog Control** option. Adjust the control voltage range in **Settings**.

Cabling

The connection cables may be purchased from Norav Medical distributors.

ACCESSORIES INSTALLATION

Installation of the Tango M2 Automatic BP Unit

Verify Correct Cables

Computer Connection

Used to communicate with the stress system. This connection enables the stress system to prompt Tango M2 when it needs a BP measurement, and allows the Tango M2 BP reading to be transferred to the stress system's display and reports.

Available connection options USB or RS232.

USB Cable part# C-USB-AB3

RS232 Cable part# RS232-C-FF

Computer side
9 pin female



Figure 17: Computer side

Tango M2 side
9 pin female



Figure 18: Tango M2 side

ECG Trigger Connection

Provides the ECG signal from the stress system to the Tango M2

ECG Trigger Cable part# C-BNC



Figure 19: Stress ECG side



Figure 20: Tango M2 side

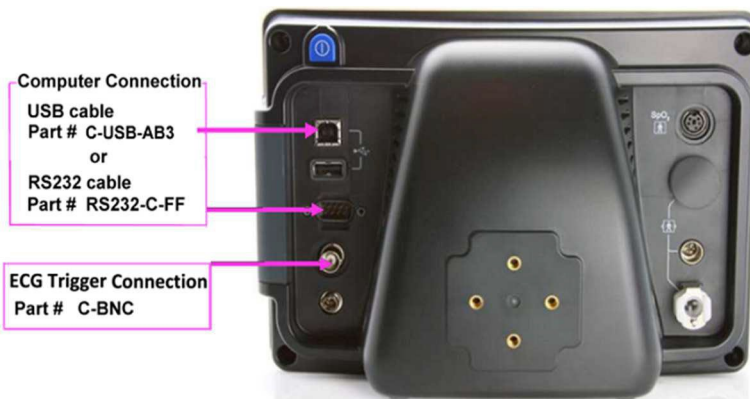

Figure 21: Tango M2 monitor back side

Connect the Computer Connection Cable (USB or RS232)

To use the **RS232** connection:

connect the **RS232-C-FF** cable between the **RS-232** connector on the rear panel of the Tango M2 monitor to **COM** port on the back of the stress system PC.

To use the **USB** connection:

connect the **C-USB-AB3** cable between the **USB B-type** connector on the rear panel of the Tango M2 monitor and an **USB** port on the back of the stress system PC.

Connect the ECG Trigger Cable

From: the BNC External ECG connection on the rear panel of the Tango M2.

To: the BNC connection on the 1200 USB-A adapter part of the Norav Stress ECG.

Tango M2 Monitor Setup

- When the operating screen is displayed, press the **SELECT** button once. This will bring up the **MAIN MENU** screen.
- Using the UP or DOWN arrows, highlight **MONITOR SET UP** and press the **SELECT** button.
- Using the UP or DOWN arrows, highlight **STRESS SYSTEM** and press the **SELECT** button.
- Using the UP or DOWN arrows, highlight **NORAV** and press the **SELECT** button.
- Using the UP or DOWN arrows, select **EXIT** to return to the **MAIN MENU** screen.
- Using the UP or DOWN arrows, select **EXIT** to return to the operating screen.

5. Norav Stress ECG System Setup

- In the Stress ECG software, go to **Setup -> Environment**
- Open the **Automatic BP COM Port** scroll box and choose the computer communication port to which you connected the Tango M2 device.
- Check **Measure BP by automatic device** option.
- Click **Advance** header, select **R-wave Trigger/Rising** option on **USB** frame.
- Click **OK** to close the Setup dialog.
- To check functionality, start a new stress test and when you click the **Measure BP** option under the **Test** main menu, the Tango M2 will take a measurement.

FAQs for Tango M2

Q. The Tango M2 displays a status message. What does it mean and what do I do?

A. See the Quick Set-Up guide (that is attached to your Tango M2) or the Troubleshooting section in your User's Guide for details on the Status Message and solution.

Q. The Tango M2 monitor returns results of 0/0 after blood pressure measurements. What do I need to do to get a BP reading?

A. There are certain noisy conditions where the Tango M2 cannot accurately measure BP. When the Tango M2 encounters these situations, it returns a reading of 0/0. Placement of the microphone attached to the cuff is critical for reliable operation of the Tango M2. Follow the instructions in the **Cuff Tutorial** (located on the SunTech Medical website under Products-> Tango M2) for correct microphone placement. Follow steps 1 and 2 in Conducting the Stress Test in the User's Guide to provide the best conditions to obtain a measurement.

Q. Can I use a heart rate or blood pressure simulator to test whether the Tango M2 is working correctly with my stress system?

A. You cannot use a heart rate or blood pressure simulator to test whether the Tango M2 is working with your stress system. The Tango M2 monitor requires that the ECG signal and the Korotkoff sounds, collected by the microphone in the cuff, originate from the same source, meaning the patient.

Q. I cannot clearly see the Tango M2 display. How do I fix this?

A. If you cannot clearly read Tango M2, you can adjust the contrast of the display by following these steps:

1. When the operating screen is displayed, press the **SELECT** button. This will bring up the main menu screen.
2. Using the UP or DOWN arrows, highlight **MONITOR SET UP** and press the **SELECT** button.
3. Using the UP or DOWN arrows, highlight **BRIGHTNESS** and press the **SELECT** button.
4. Using the UP or DOWN arrows, select **EXIT** to return to the main menu screen.
5. Using the UP or DOWN arrows, select **EXIT** to return to the operating screen.

Q. My Tango M2 displays a message, “Please VERIFY CALIBRATION” or “Equipment Maintenance and Calibration Required.” What do I do?

A. Verification of Pressure Calibration

Equipment Required:

Calibrated electronic manometer or equivalent.

500mL volume or the Orbit-K Adult Plus cuff wrapped around something that will not break or crush (no glass).

Hand Inflation Bulb with bleed valve.

Tubing, Tee pieces, and miscellaneous connectors or you can order the T-Tube Kit (SunTech Part # 98-0030-00).

Procedure:

1. When the operating screen is displayed, press the **SELECT** button 2 times. This will bring up the **MAIN MENU** screen.
2. Using the UP or DOWN arrows, highlight **MONITOR SET UP** and press the **SELECT** button.
3. Using the UP or DOWN arrows, highlight **VERIFY CALIBRATION** and press the **SELECT** button. The monitor will close its bleed valves and will display on its screen the pressure applied to the patient hose connector.
4. Verify the Tango M2 calibration by manually inflating and checking the manometer against the pressure reading on the Tango M2 display.
5. Once the calibration has been completed, use the UP or DOWN arrows to select **EXIT** twice and return to the operating screen.

PATIENT PREPARATION

The ECG traces quality depends very much on the stability and conductivity of the electrodes during the test, especially during high stages of Cardiac Stress test when the patient movements can cause artefacts. Here are some basic rules to ensure good electrical contact:

- ◇ Shave hair from the area where electrodes are to be applied.
- ◇ Abrade these areas with fine sandpaper or an abrasive pad.
- ◇ Thoroughly clean the electrodes area with alcohol.
- ◇ Let dry prior to applying the electrodes.

ECG Electrodes

**Note**

Many ECG adhesive electrodes are suitable for use. As ECG electrodes from different manufacturers have different electrical properties, the choice of ECG electrodes can considerably affect the measurement results and quality. Ensure that only high-quality electrodes are used. Wet gel electrodes are recommended.

Always refer to the ANSI/AAMI EC12:2000 Standard for safety, performance, and labeling requirements for the disposable electrodes, and guidelines for reliable patient connections.

RESTING ECG

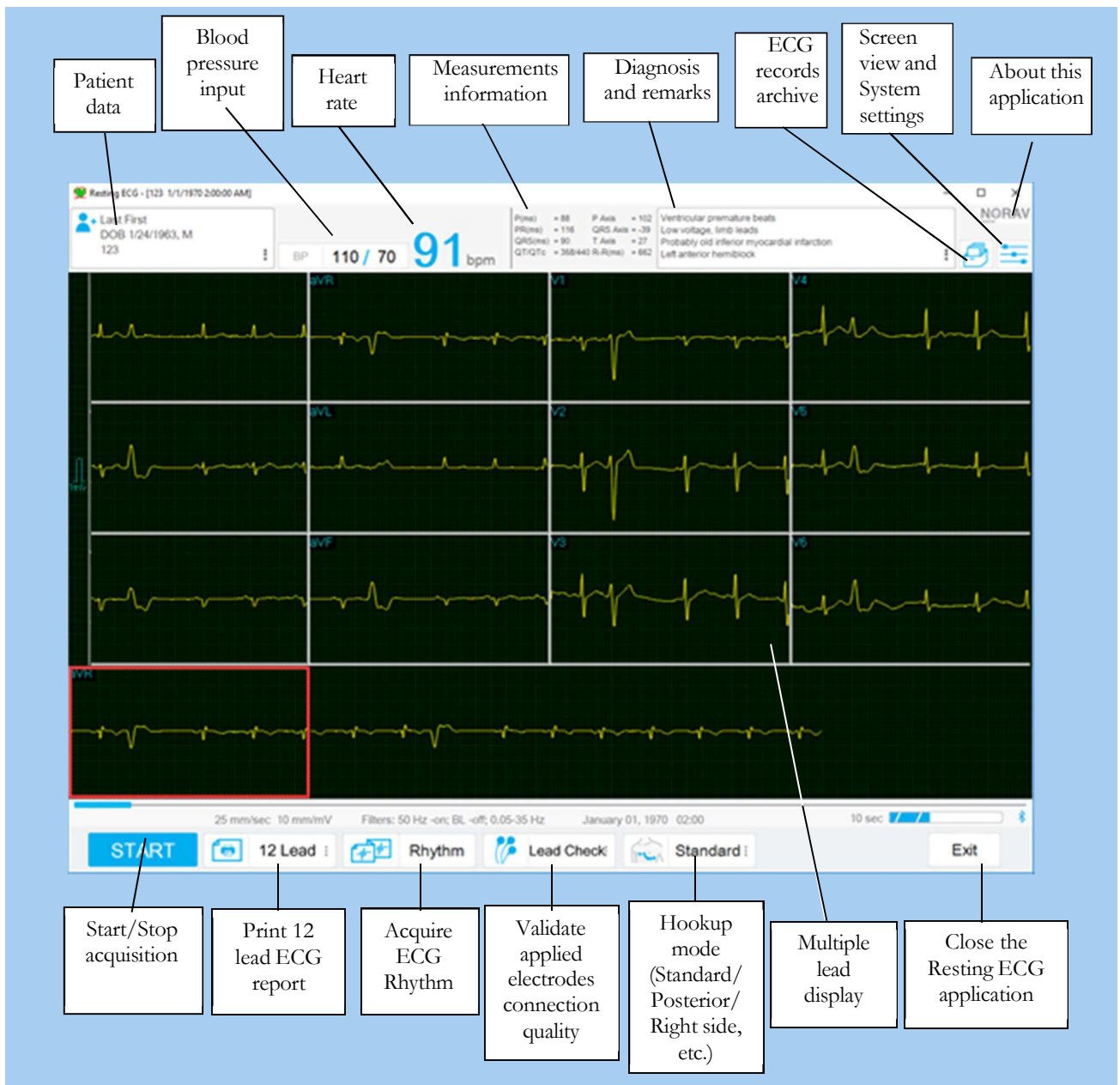

Figure 22: Resting ECG Main Screen

Quick Start

To Perform a New Test

1. Hook up the Patient

- a. Prepare the skin
- b. Connect electrodes

This application uses the standard 10-electrode cables with all Norav ECG modules, or optional 14-electrode cable with the 1200HR module for 15/16-lead ECG acquisition, or optional 5-electrode cable with NR-1207-E / NR-1207-3 modules for Derived 12-lead ECG acquisition.

Hook up with 10-electrode cable

The cable electrodes can have the AAMI labels or IEC labels.

The usual method is to place the leads in the standard positions, as shown below.

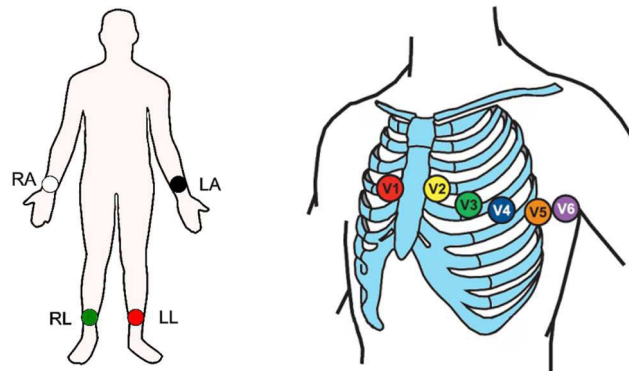

Electrode		Lead	Electrode Placement
AAMI	IEC		
RA	R	RA	right forearm or wrist
LA	L	LA	left forearm or wrist
LL	F	LL	left lower leg, proximal to ankle
RL	N	RL	right lower leg, proximal to ankle
V1	C1	V1	4-th intercostal space, right sternal edge
V2	C2	V2	4-th intercostal space, left sternal edge
V3	C3	V3	midway between V2 and V4
V4	C4	V4	5-th intercostal space, mid-clavicular line
V5	C5	V5	anterior axillary line in straight line with V4
V6	C6	V6	mid-axillary line in straight line with V4 and V5

Figure 23: Standard 12-lead Resting ECG electrode placement

With above lead placement method, the standard 12 derivations are recorded and displayed on PC screen and on print reports:

- 3 Bipolar derivations: I, II, III
- 3 Augmented derivations: aVR, aVL, aVF
- 6 Unipolar derivations: V1...V6

Additionally, you can place the leads on the patient in other hook up scheme, such as Posterior (V7...V9), Right Side (V3R-V6R) or Pediatric (V7, V3R, V4R).

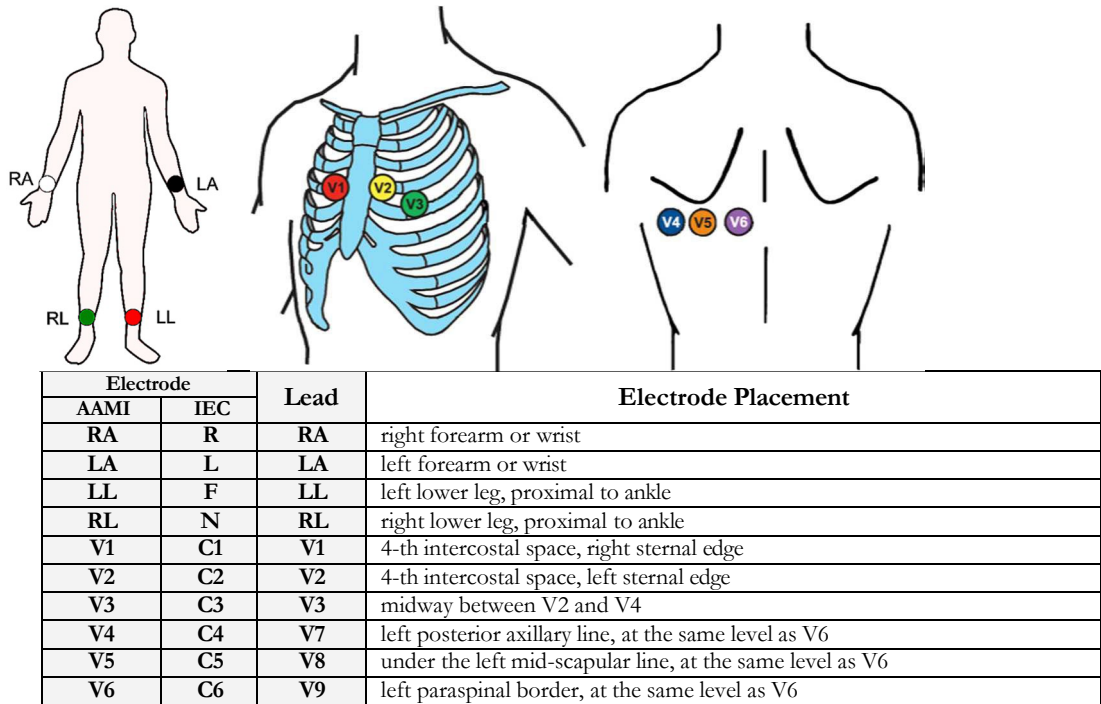

Figure 24: Posterior lead placement with 10-electrode cable

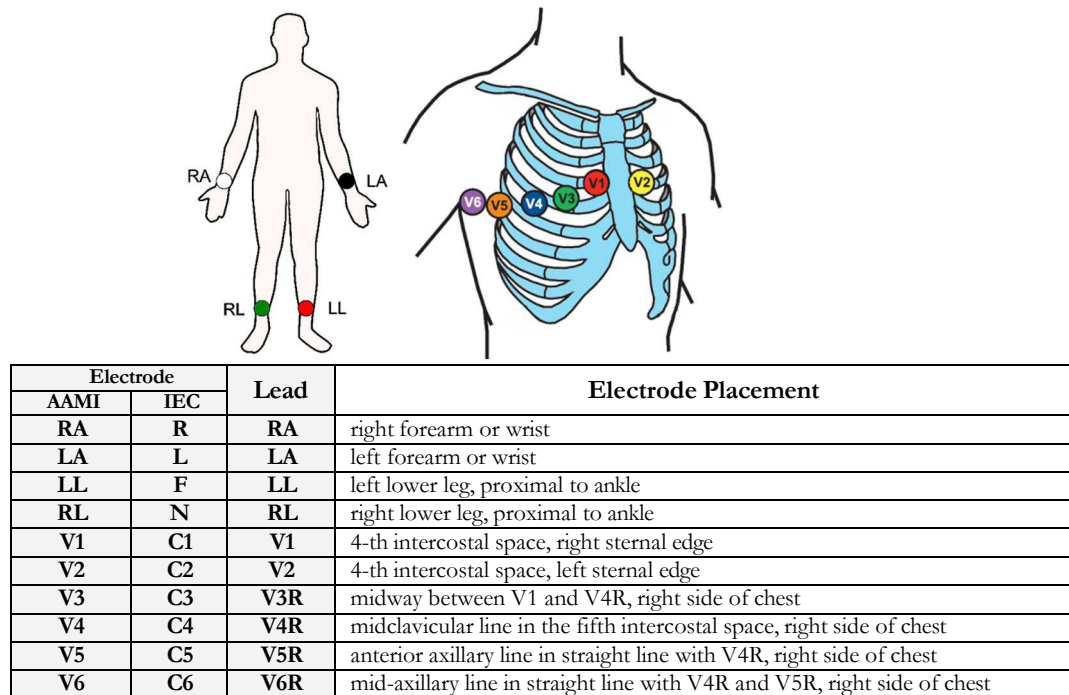

Figure 25: Right Side lead placement with 10-electrode cable

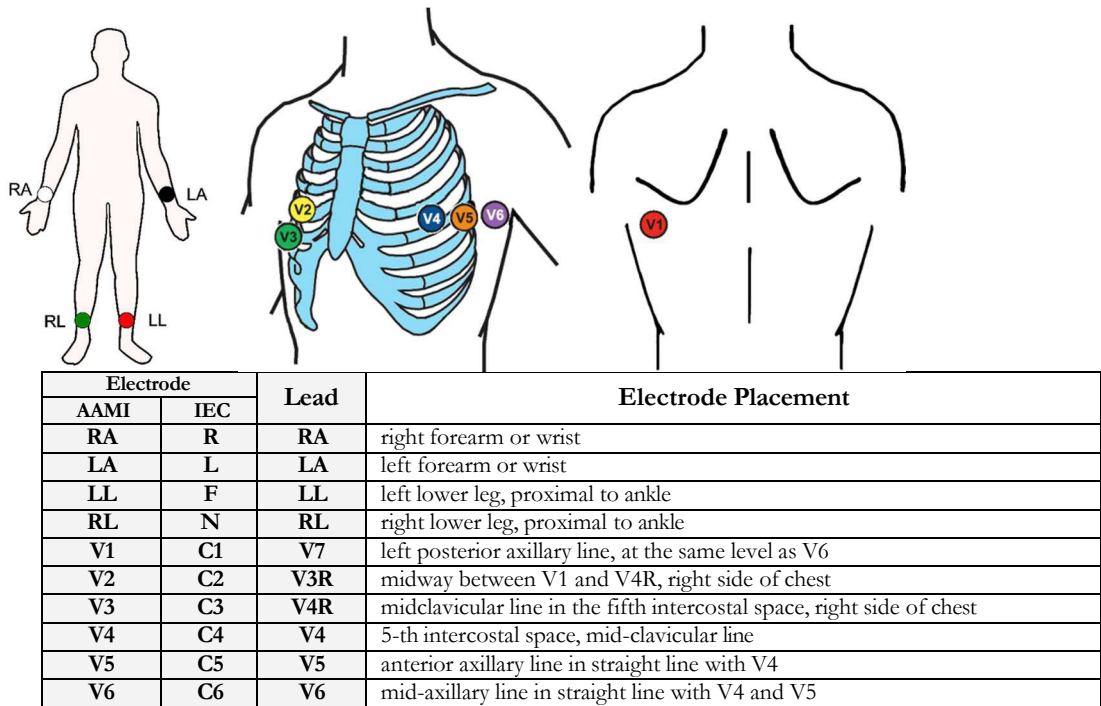

Figure 26: Pediatric lead placement with 10-electrode cable

Hook up with 14-electrode cable

The 14-electrode cable contains 10 standard electrodes marked by the AAMI or IEC standard labels, plus four additional electrodes marked as H, M, I and E. The supported lead placement schemes are mentioned in below tables.

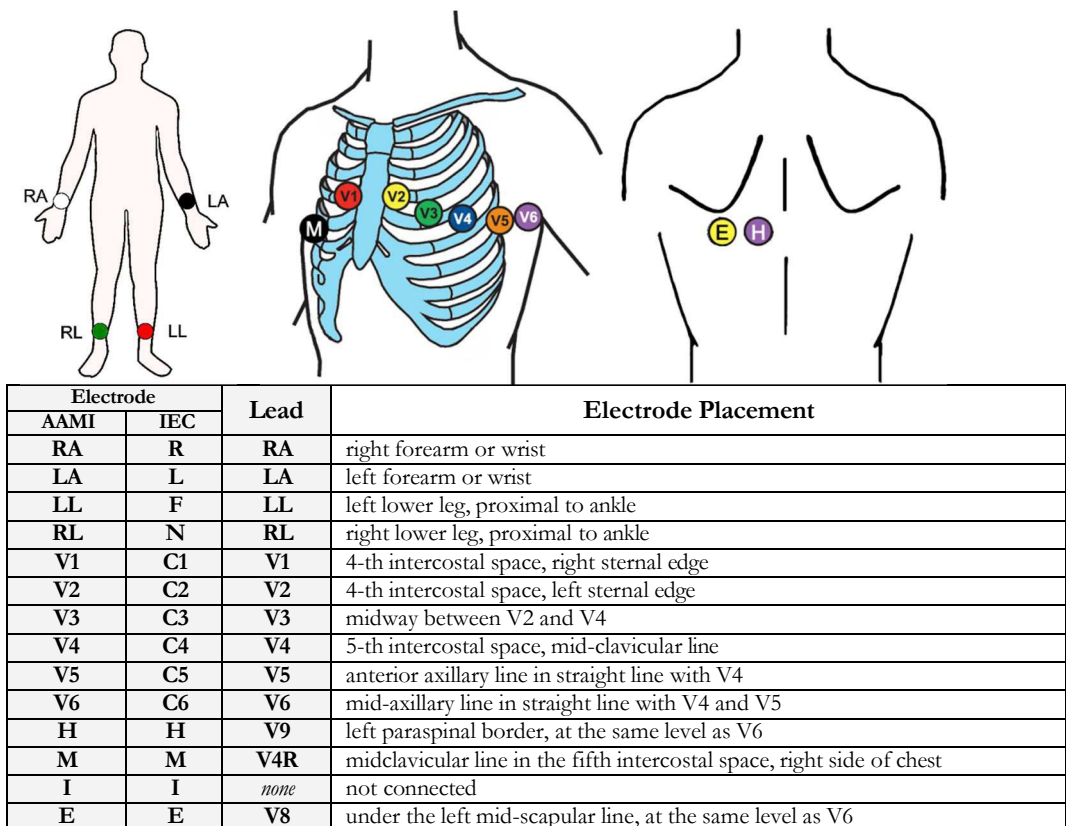

Figure 27: Standard 15-lead lead placement with 14-electrode cable

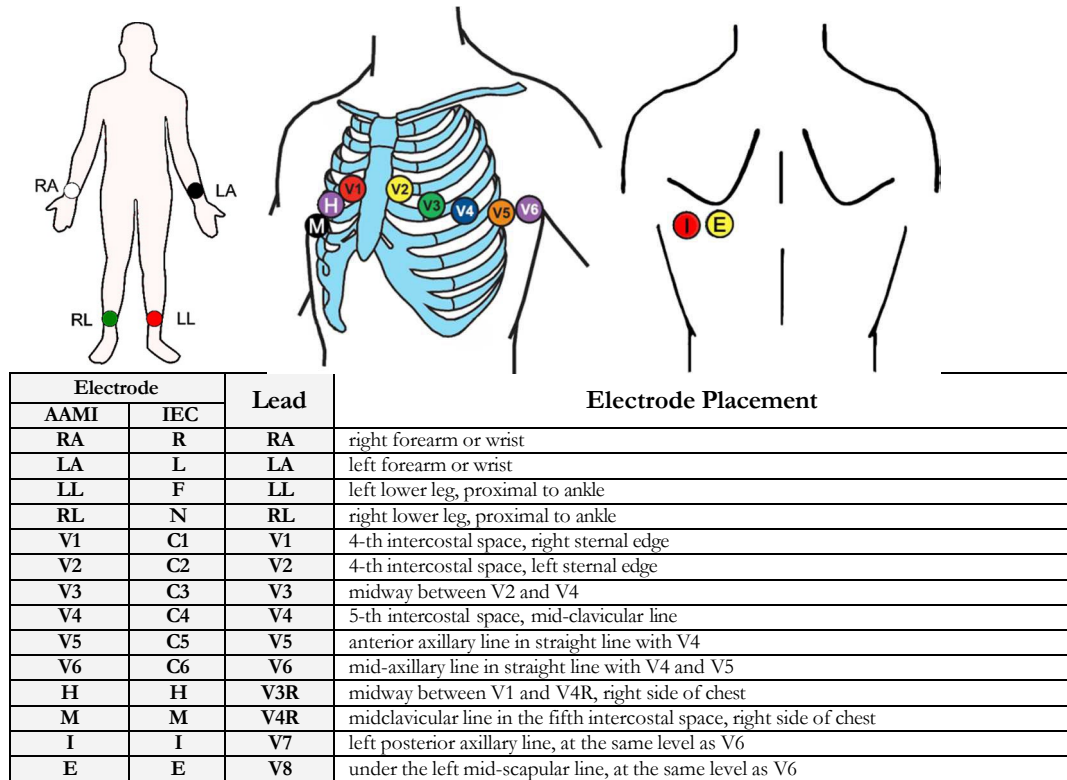

Figure 28: Adult 16-lead lead placement with 14-electrode cable

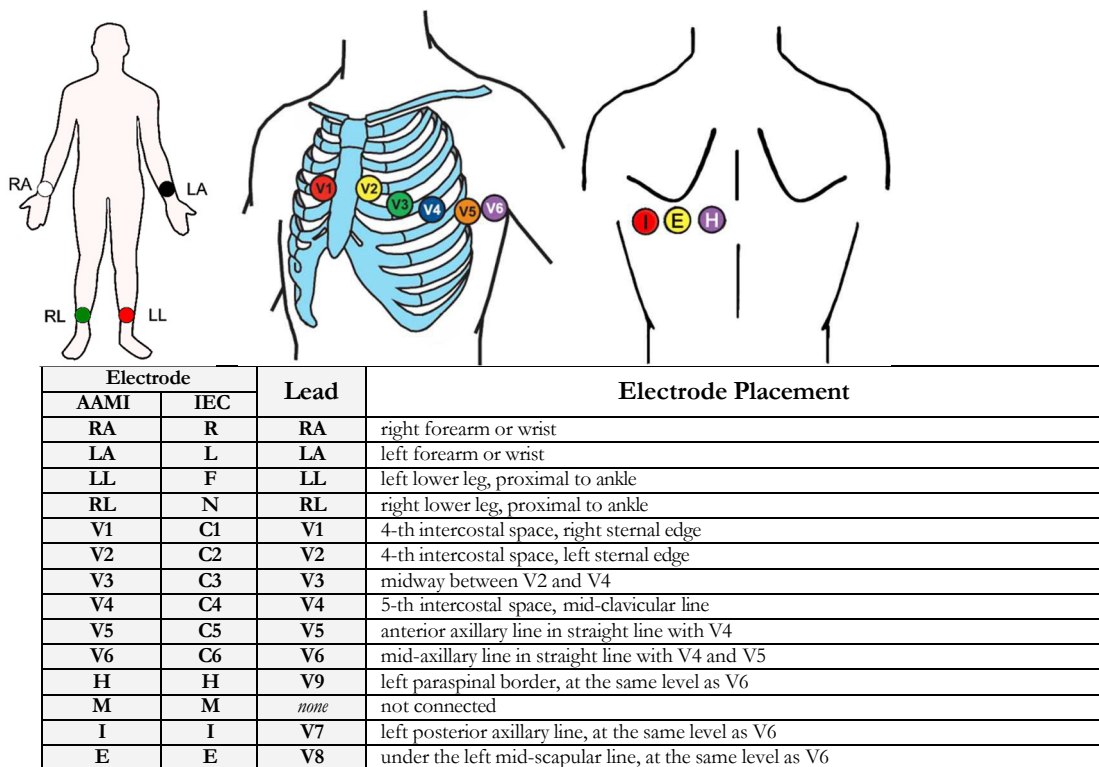

Figure 29: Posterior 15-lead lead placement with 14-electrode cable

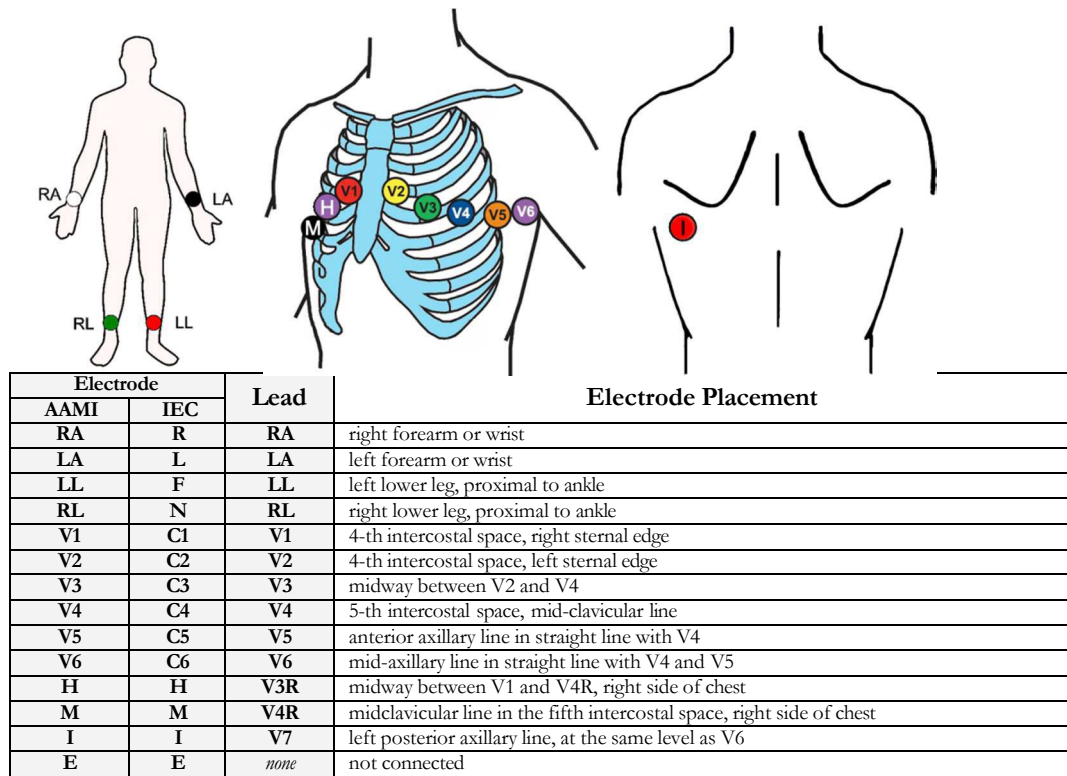

Figure 30: Pediatric 15-lead lead placement with 14-electrode cable

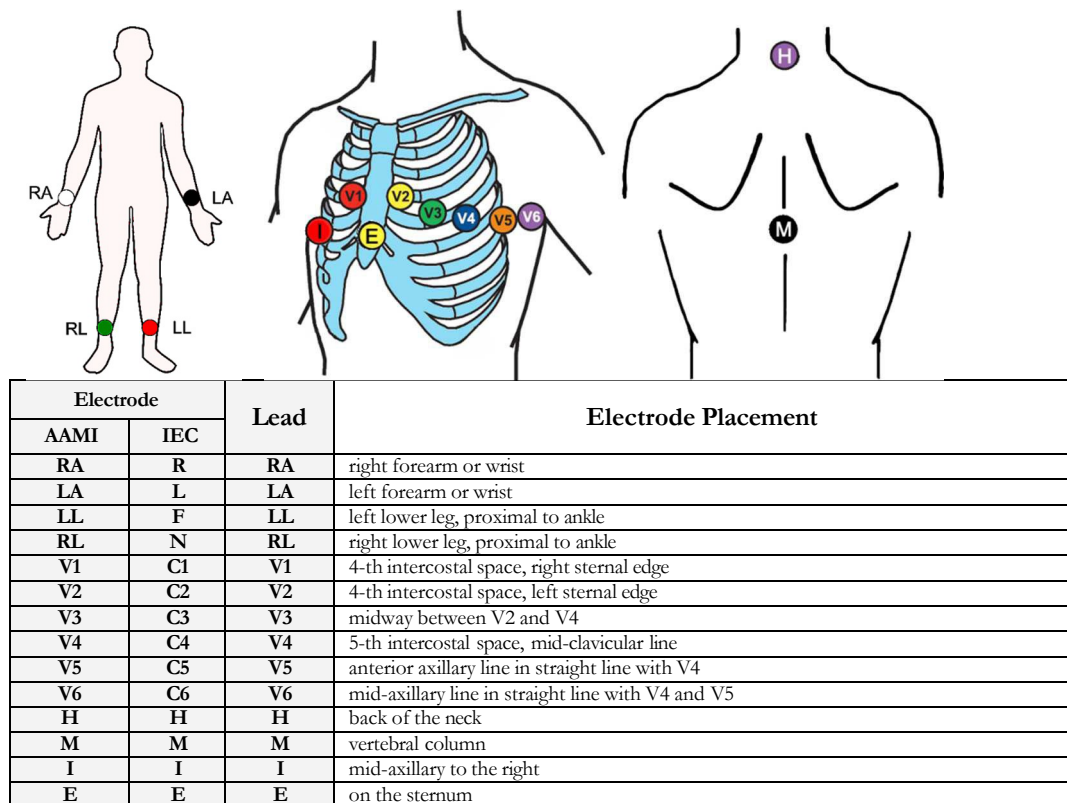

Figure 31: Frank XYZ lead placement with 14-electrode cable

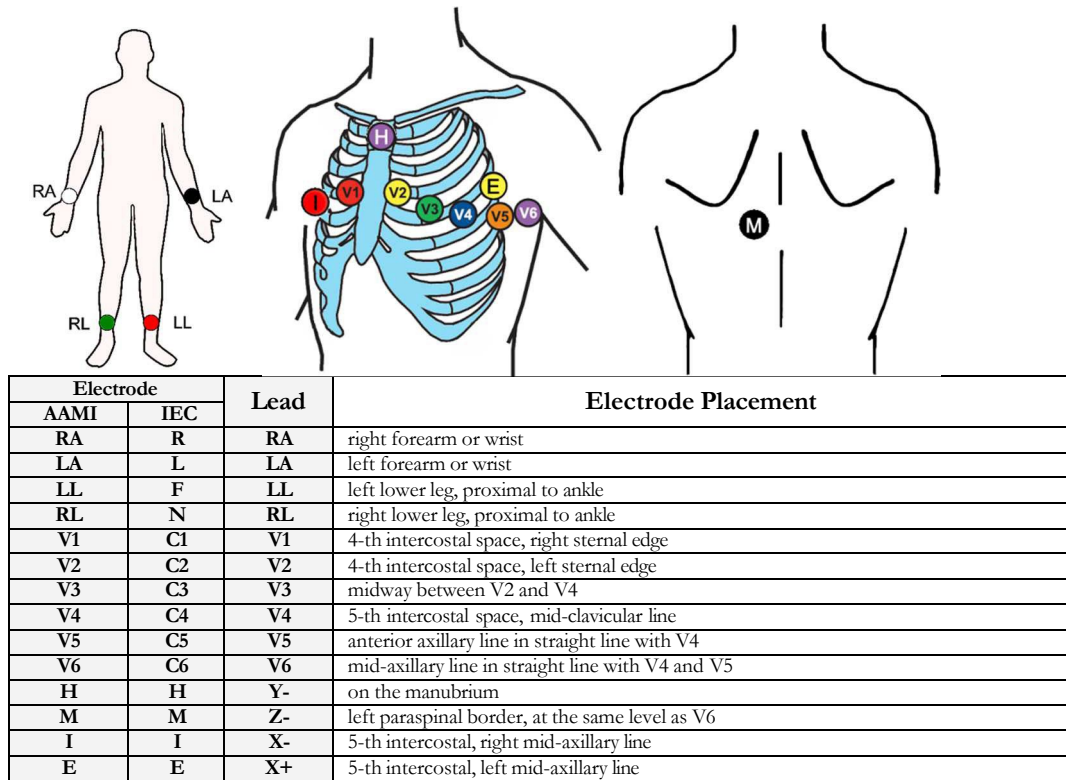

Figure 32: Bipolar XYZ lead placement with 14-electrode cable

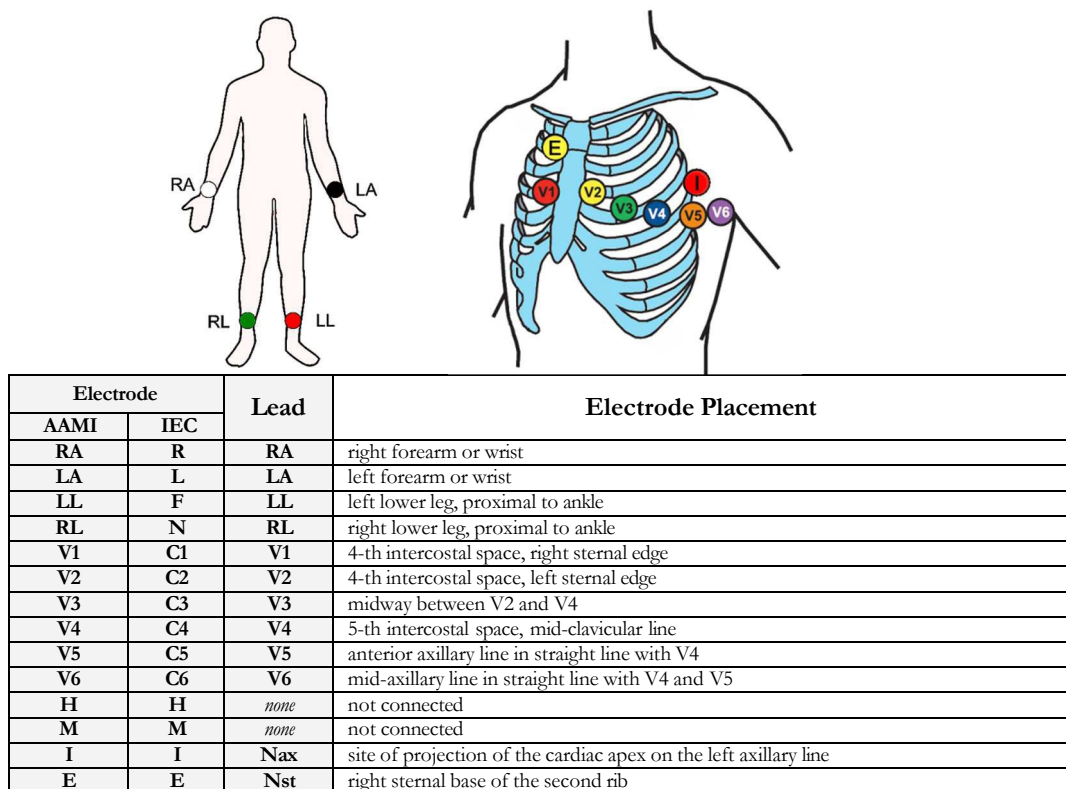
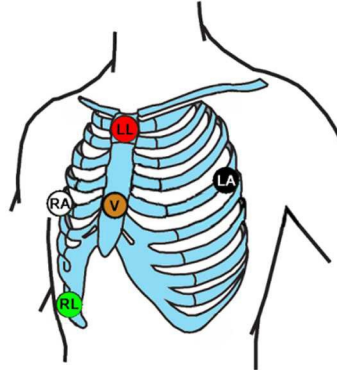

Figure 33: Nehb lead placement with 14-electrode cable

Hook up with 5-electrode cable

Used for Derived 12-Lead ECG acquisition. The cable contains 5 electrodes marked by the AAMI or IEC labels. The lead placement scheme is mentioned in below table.



Electrode		Electrode Placement
AAMI	IEC	
RA	R	in the right midaxillary
LA	L	in the left midaxillary
LL	F	on the manubrium sterni
RL	N	on the right lower edge of the rib cage
V	C	at the level of the fifth of the lower sternum

Figure 34: Derived 12-Lead ECG lead placement with 5-electrode cable



Note

Derived from 5-electrode cable 12-Lead ECGs and their measurements are approximations to conventional 12-Lead ECGs and should not be used for diagnostic interpretations.

1. Start a new test

Run the Resting ECG application. Open the patient details panel by clicking the



icon on upper tool bar or by press the **F1** keyboard key.

Insert patient details then click **OK** button or press the **ENTER** keyboard key.

2. Validate the applied electrodes connection quality

Click the  **Lead Check** button to show the schematic torso picture which allows to verify the applied electrodes connection quality and the lead off status.

3. Acquire an ECG

Verify that all ECG traces are acquired and correctly displayed on the screen.

Freeze ECG by clicking the  button (after at least 10 seconds) or by pressing the **F2** keyboard key.

4. Create a report

To write review: open the **Remarks** main menu panel.

To print report: click the  **12 Lead** button or by press the **F6** keyboard key.
For an example of a printed report, see Appendix C.

Operation with Function Keys and Hotkeys

F1	New Recording
F2	Start/Stop ECG
F3	Collect 10 second ECG
F6	Print
F11	Open Saved Study List
Ctrl “+” / Ctrl “-” or Ctrl <i>and</i> mouse wheel	ECG traces Zoom In /Zoom Out
Ctrl “0” or mouse right button double-click on ECG traces	Reset Zoom

Table 8: Operation with Function Keys



Note

Before using the Resting ECG application define preferred parameters in Setup. Otherwise the program will operate according to the factory setup.

Toolbars and Panels

Toolbar Overview













To do this	Click this icon	Or use this short-cut key	Or select this menu	Description
Start/stop the ECG recording	 	F2		To start/stop the ECG acquisition
Patient information		F1		Displays the patient information.
Print the ECG page	 12 Lead :	F6		Prints the 12 lead ECG
Save the ECG Rhythm	 Rhythm			Continuously stores the ECG rhythm
Enter the blood pressure	BP /			Input control for enter the BP values
Diagnosis/Remarks				To enter the ECG diagnosis and remarks
Configuration and filters				To adjust the screen layout, ECG filters and the system configuration
About the program				Displays the software version, license information and Norav contact details
Lead Check	 Lead Check :			Displays the schematic torso picture to verify the applied electrodes connection quality and the lead off status.
Lead System	Posterior : Right Side : Pediatric : Standard :			Defines the electrode placement on the patient.
Data archive				Opens an existing study from local folder or from NEMS database
Exit application				Ends the ECG session, saves the data and exit the Resting ECG program

Table 9: Resting ECG tool bar commands

ECG Screen View and Filters panel

The screen view panel opens on click the  button.

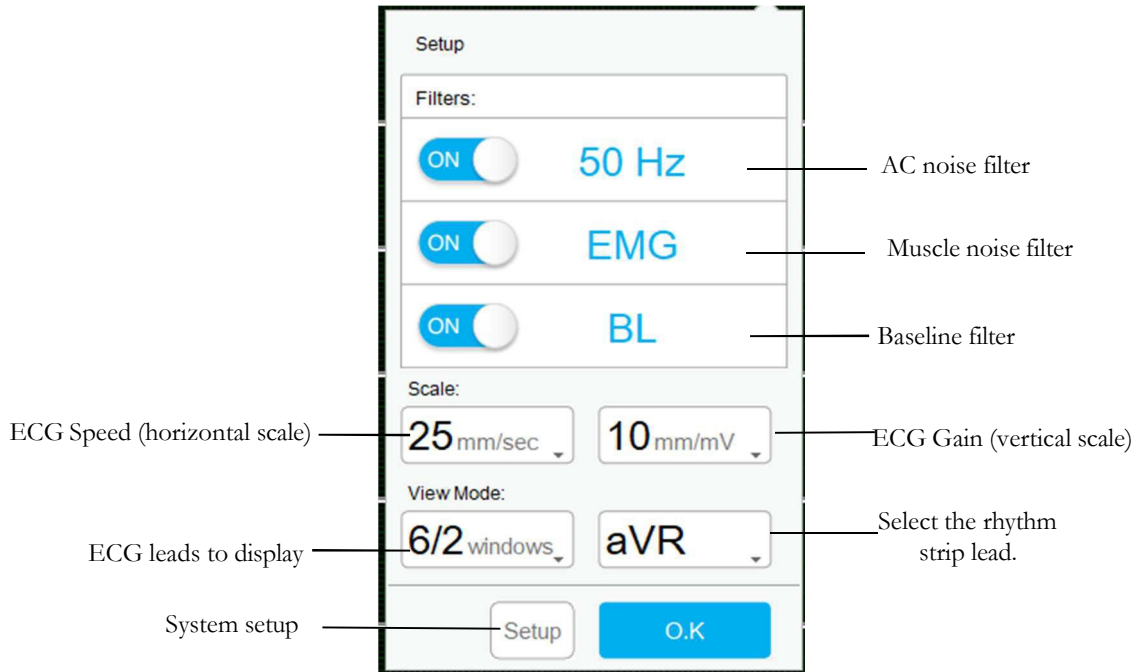

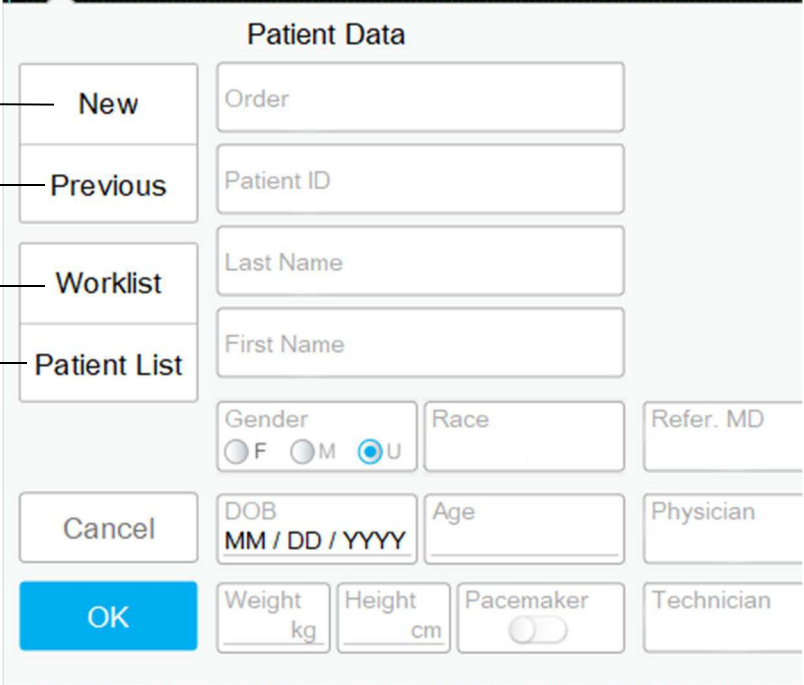

Figure 35: Resting ECG Views and Filters panel

Patient Information panel

To enter the patient details open the patient information panel by click the  icon.



The screenshot shows the 'Patient Data' panel with the following fields and controls:

- Buttons:** New, Previous, Worklist, Patient List, Cancel, OK.
- Text Fields:** Order, Patient ID, Last Name, First Name, Race, Refer. MD, Age, Physician, Technician.
- Gender:** Radio buttons for F, M, U (U is selected).
- DOB:** MM / DD / YYYY.
- Weight:** kg.
- Height:** cm.
- Pacemaker:** Toggle switch.

Callouts from the left side of the image point to the following buttons:

- New:** Create new patient and start ECG
- Previous:** Retrieve the last entered patient name
- Worklist:** Select patient from Worklist
- Patient List:** Select patient from NEMS database

Figure 36: Resting ECG Patient Information panel

Resting ECG System Setup



To access the system setup click the  button on a main tool bar and then click 

Tab	Option	Description
Leads	Lead Systems	Define the lead system to use according to the patient cable and the electrode placement scheme.
	Default 3 leads	Define the 3 leads to display as default when using the 3x1 view format.
	Default 6 leads	Define the 6 leads to display as default when using the 6x1 view format.
	Strip Lead	10 sec lead to appear in 4x3, 4x4, 3x5, 6x2, 6+9 and 6+10 view formats. Note: <i>the strip lead could be defined different per each Lead System.</i>
	15 Leads	Define the 15 Lead leads placement options, with 14-electrode ECG cable (with 1500HR model only).
	Derived 12 Lead 5-electrode Placement	Define the optional "Derived 12 Lead" mode for NR-1207-E and NR-1207-3 devices with 5-electrode ECG cable.
ECG Recording	Filter 50/60Hz	Default is cleared. When checked, the default status of 50/60Hz filter is ON (according to the checked frequency 50 or 60).
	EMG Filter	Default is cleared. When checked, the default status of the EMG filter is ON. User may also select necessary cut-off frequency for EMG filter: 20Hz, 35Hz, 40Hz or 100Hz. The default value is 35Hz.
	Baseline Filter	Default is cleared. When checked, the status of the Baseline filter is ON.
	Save options	If Auto Save is ON, the recording file is stored according to naming conventions selected in the Set File Name by panel. If Auto Save is OFF, the user is asking to enter a file name.
	Auto stop after 10 sec	If cleared (default), recording runs till stopped by the user. If checked, stops recording automatically after 10 sec.
	Auto Print	Use this option for automatic 12 lead ECG printing at the end of the test. If more than one printer is defined in the network, select the appropriate one from the list.
	Simulator ECG	If cleared (default), ECG recording is done from the PC-ECG unit. If checked, the ECG recording is done from the demo file included in the software package. In this case, the recording unit is not needed.
	Longest ECG recording time	Set maximal limit for ECG recording time in Rhythm mode.
	Minimum Test Time	Set minimum test time for any test (in seconds). During this time, the Stop button (F2) will be disabled and the test cannot be stopped.
	Data Directory	Allows the user to define a directory for saved ECG recordings (if ECG database is not used). Use a secondary hard disk, if one is available.
	Use ECG Database	Select this option to connect to the optional ECG database (NEMS).
	Backup Data directory in AutoSave mode	When Auto Save option is selected, this allows the user to define a local path for a backup directory. The backup directory is useful when the data directory or database is not on the same computer. In such a case, ECG file save can fail due to failure in connection.
	Validate Patient data	Patient mandatory details must be entered at the start of the new test.
	Input Range (0-9)	Restricts the Patient ID input value to digits only. Default is cleared.
Prevent Multi Instance session	Protects against ECG device acquiring from several logon sessions on the same computer simultaneously. Select this option when the PC ECG is installed on an organization's computer where 'Switch User' logon function enabled. Default is cleared.	

Tab	Option	Description
	Sample Rate	Allows the user to choose the ECG acquisition sampling rate.
	Auto Start Acquisition	If checked, the ECG acquisition is started automatically on run the Resting ECG program. Default is checked.
Diagnosis		Some features are optional, active only if the option (I1/I3) is installed.
	ST after J	Defines the ST spot relative to the J point.
	Default "Confirm Diagnosis" status	Relates to the checkbox status of the Confirm Diagnosis on the Remarks dialog of the Interpretations . If checked, the default value of the checkbox on the Remarks dialog will be checked. If not checked, the checkbox on the dialog will be unchecked.
	Print Options	Define if measurements and/or interpretations should be added to printouts. Options are Never , After Confirmation , or Always .
	Display Options	Define if measurements and/or interpretations should appear on display. Options are Never , After Confirmation , or Always .
	Enable the ECG Measurements tool	If checked, the user can open the ECG Measurements tool by click on the measurements area in the upper tool bar.
	QTc Calculation	Allows selection of the formulas used for Corrected QT Interval calculation. Available choices: Bazett , Fridericia , Framingham , Hodges . Default: method 1 Bazett , method 2 "none"
View	Draw over lead borders	If checked (default), does not limit the extreme high amplitude ECG pulses from exceeding the borders. If cleared, chops the pulses at the borders.
	View calibration pulse 1 mV	If cleared (default), the 1 mV pulse will appear only in printing. If checked, the 1 mV pulse will also appear on the screen.
	Leads Base line shift	If cleared (default), the base line of each lead is exactly in the middle of the lead's area. If checked, a special shift is added to each lead to view its maximum. For example: lead V6, being positive pulsed, gets negative shift.
	Separate Leads	If checked, leads are displayed framed and separated from each other. If cleared, leads are not separated. Default is checked.
	Draw Grid	If checked, displays grid lines when the application is opened. If cleared, the application is opened with no grid lines. Default is checked.
	1 mm	If checked, the on-screen grid appears with 1 mm cell size. When not checked, the grid cell size is 5 mm. Default is checked.
	Open in Tile mode	Select Tile mode to set the mode (horizontal or vertical) which 2 or more opened tests will be viewed.
	Horizontal Scale	Sets the default value for the horizontal scale window on screen (mm/sec).
	Vertical Scale	Sets the default value for vertical scale window on the screen (mm/mV).
	Draw Pacer	When enabled, an artificial marker (vertical dashed line) replaces the detected pacemaker spike on the ECG trace on screen and on printout. If the option is not enabled (default), pacemaker spike is shown as is. Note: this artificial marker is relative of time but is not representative of either pacemaker' pulse real amplitude, polarity or width.
	Color selection	Allows the user to choose the screen colors for the Rest ECG application for background, traces, grid, and text.
	Restore Defaults	When activated, restores the factory default colors.
	Default ECG View	Select the default on-screen lead display from the list in the combo box. There are two configuration settings for this parameter. The first one is for 12-lead recording mode, and another one (available for the 1200HR model only) is for the extended 15-lead/16-lead recording mode.
	Smooth ECG Trace	Check this option to display a smooth ECG trace on the screen.
	Close previous ECG	Closes the opened ECG record upon starting a new test. If this is unchecked, all reviewed or created ECG records remain open in the background until the program exits. Default: enabled.

Tab	Option	Description
	Show the worklist	When enabled, on start new test the worklist panel appears raiser than patient details panel.
	Calculate Body Surface Area	Default: disabled. Displays the estimated body surface area of the patient on screen and in the printout. Select from these five formulas: Mosteller (default), DuBois , Haycock , Gehan , Boyd .
	Show Rhythm	Show/Hide the Rhythm button. Default: checked.
	Default Zoom	Defines the default zoom scale of the ECG traces on screen. In real time the zoom scale can be changed with Ctrl “+” (Zoom In) and Ctrl “-” (Zoom Out) keyboard shortcuts or by using the mouse wheel together with Ctrl keyboard key. To reset zoom to 100% use the Ctrl “0” keyboard shortcut or double click the mouse right button at any point on the ECG traces. To disable zoom scale select “<-none->” for Default Zoom.
	Screen Mode	To switch the screen view between the regular PC-ECG mode (default) and the Transport Monitor view showing an additional parameters such as SpO ₂ , respiration rate, body temperature and EtCO ₂ level.
Installation		Saves an organization name, address, logotype and a workstation (modality) name. This data appears on printout and on PDF report.
	Supervising Physician	Add/Edit a Supervising Physician’ name, password and personal signature stamp. Select from list and set as Default Supervising Physician.
	Technician	Add/Edit a Technician’ name to list. Select from list and set as Default Technician.
	Referring Physician	Add/Edit a Referring Physician’ name to list.
	Measurement Standard	Define whether measurements will be calculated according to the metric or the USA standard. Default is metric.
Environment	ECG Device Connection	To choose the port for interface with ECG the device. Available options: COM Port , USB (default) and Bluetooth .
	Display Size	This setting is required in order to display the ECG and grid in the correct scale. User can define the size of the PC display manually or select the Auto-detect option to automatically detect the PC display size.
	Graph paper	If enabled, prints the 1 mm and 5 mm squares on printouts. Regular Grid is guaranteed to fit any printer. Improved Grid shows a fine grid but may not work on some printers.
	Paper Size	To choose the A4/Letter conventional printer or 4-inch thermal printer.
	Use large fonts for remarks	Enables large font for user entered free text.
	Color Printout	Select this option for color printouts.
	Shadow/Frame For Area of Interest	Allows the user to choose between shadow and frame to highlight the interest area.
	Leads Print	Simultaneous (default) prints the simultaneous segments of ECG data for each of the leads synchronised with time point of the frame on a full 10 seconds bottom strip. The term “simultaneous” refers to the fact that the data presented for each lead taken at exactly same time. Successive report shows a sequential sample of ECG data from each of the 12 channels. Each successive channel has the next time zone of ECG data of the total of 10 seconds of data. The beginning of each channel is marked by a vertical line and the channel identifier in bold letters. The bottom trace on the graph features ten seconds of data. It also serves as a time stamp for the entire report. Each QRS complex in this trace is the same on found in other traces above it.
Print Scale Format and Print Page Format	Configures the page view for ECG reports. Can be set to same layout as it appears on the ECG software screen either with statically defined leads set, speed and amplitude.	

Tab	Option	Description
	Default Reports	Final reports selector. Available options: - ECG Traces (standard 12-lead ECG printout). - Measurements and Vector Loop (comprehensive report including the measurements matrix for all 12 channels and Vector Loop circles). - Tabular Summary (only for records acquired in Transport Monitor mode).
	Enable real-time print	Show/Hide the Rhythm button for continuous ECG strip recording with up to maximal duration defined by the <i>Longest ECG Recording time</i> parameter of the ECG Recording setup tab.
	Check NET Key	Check this option if software license is installed in network (NetHASP).
	BP Device	To configure the interface with optional automated blood pressure monitor (SunTech "Aura"). Applicable only for NR-1207-3 recorders having the appropriate hardware module inside.
Picture Format	AutoSave ECG in Picture Format	Select this option to save the test automatically as a JPEG image.
	Set File Name By	Set the file names to include Patient Last Name or Patient ID. Check date and/or hour to include them in the file name.
	Picture Format	Select the resolution of the picture (normal or high resolution).
	Picture File Type	Select picture JPG/TIF/Both as file type for picture
	Pictures Directory	Set the directory for saved pictures. The default is C:\ProgramData\NoravMedical\PCECG\Data\.
External Interface	GDT/BDT Format	Setup the GDT/BDT interface.
	Save test in GDT/BDT	If checked, save test automatically to GDT/BDT format.
	Import from GDT/BDT	If checked, imports tests automatically as GDT/BDT format.
	File Format	Select the file format: GDT or BDT.
	Import/Export Codepage 437	Check this option to import/export Code page 437.
	Edit Labels	Click this button to open a dialog box with an editable list of the field labels used in the GDT and BDT files.
	GDT/BDT Data Directory	Specifies the directory path where the GDT/BDT files should be maintained.
	Token for PCECG	Default is PEKG .
	Token for Practice EDP	Default is EDV1 .
	Validate Mandatory Entries	Default unchecked. If checked, the program validates the incoming GDT command for existing data in entries marked as mandatory in ECG Recording tab.
	Notifications	Configure notification protocol with external software
	Disabled	No notifications
	Infocom	Enables the TCP socket notification interface with Infocom system
	IP Address	Network IP address of the target Infocom system
	Port	TCP port number of the target Infocom system
	ENWA	Enables the file-exchange notification interface with ENWA system
	Command Directory	Set the exchange directory for notifications and command files for ENWA system communication
Start Filename	Specifies the filename for <i>START CAPTURE</i> notification	

Tab	Option	Description
	Stop Filename	Specifies the filename for <i>STOP CAPTURE</i> notification
	Event Filename	Specifies the filename of the <i>USER EVENT</i> incoming command
TXT/CSV	Auto Save test Data in Text/CSV file	Select this option to save the test data in a text/CSV file automatically at the end of the rest test.
	Set Text file Name by	Set the text/CSV file name according to Test File Name or according to the fields Patient ID and/or Patient Last Name.
	Text/CSV File Data Directory	Set the directory path to maintain the text/CSV files with the ECG data. Default path is C:\ProgramData\NoravMedical\PCECG\Data\.
	Values	Define the data values in the CSV file: <i>Events only, Every 1 minute or All</i> . This option is only relevant for the Transport Monitor view mode.
	Conversion TOOL	Configuration settings for mode when the application is used to convert the ECG RAW data files to Excel, TXT or XML format.
FDA XML \ SCP\Mckesson \MFER\ Raw Data format	FDA XML format	Set FDA XML saving options, ID Root and directory
	Auto Save in FDA XML format	Select this option to save the test data in a FDA XML file automatically at the end of the rest test.
	Annotations for leads	Check this option to set annotations for leads. Select the leads that should be annotated. If not checked, the leads are disabled and no annotations will be saved in the FDA XML file.
	File Data directory	Set the directory path to maintain the FDA XML files with the ECG data. Default is C:\ProgramData\NoravMedical\PCECG\Data\.
	Parameters	Insert ID Root for the FDA XML file
	SCP format	Set Autosave option for SCP format and the SCP files directory. Default is C:\ProgramData\NoravMedical\PCECG\Data\.
	Mckesson format	Set Autosave option for Mckesson format and the Mckesson files directory. Default is C:\ProgramData\NoravMedical\PCECG\Data\.
	MFER format	Set Autosave option for MFER format and the MFER files directory. Default is C:\ProgramData\NoravMedical\PCECG\Data\.
	Raw Data format	Set Autosave option for Raw Data format and the Raw Data files directory. Default is C:\ProgramData\NoravMedical\PCECG\Data\.
PDF/HL7 File/DICOM ECG	Auto Save test Data in PDF format	Select this option to save the test data as a PDF file automatically at the end of the rest test.
	Open PDF after recording	Displays the automatically created PDF files on screen (external PDF Viewer software is required).
	Set PDF file name by	Set the PDF file name according to Test File Name or according to the selected field.
	PDF File Data Directory	Set the directory path to maintain the PDF report files. Default is C:\ProgramData\NoravMedical\PCECG\PDF\.
	Auto Save test Data in HL7 format	Select this option to save the test report as a HL7 file automatically at the end of the rest test.
	With PDF report included	Select this option to embed the PDF report as a Base64 coded image inside of the HL7 file.
	Configuration	Set the pre-defined values for configurable fields of the HL7 report file.
	HL7 File Data Directory	Set the directory path to maintain the HL7 report files. Default is C:\ProgramData\NoravMedical\PCECG\HL7\.
	Set HL7 filename by	Defines the HL7 filename format: according to the ECG record filename or formatted by OrderNumber+TimeStamp information.
	Auto Save test Data in DICOM ECG	Generate the DICOM 12-Lead ECG Waveform format file (*.DCM)

Tab	Option	Description
	Auto Save test Data in DICOM Encapsulated PDF	Generate the DICOM Encapsulated PDF report file (*.DCM)
	Auto Save test Data in DICOM Secondary Capture Image	Generate the DICOM Secondary Capture Image report file (*.DCM)
	File Data Directory	Set the output directory for DICOM files (*.DCM).
	Validate patient in MWL	If checked, the not filled patient name and ID fields in DICOM report will be updated according to DICOM Modality Worklist.
	Update DCM files	If checked, will update the DICOM report with additional data contained in the DICOM Modality Worklist.
	Store in PACS	If checked, the generated DICOM report files (*.DCM) will be immediately send to the PACS server.
	Resend Files	Click this button to manually resend the DICOM files located in the FileDataDirectory \Outbox folder to the PACS Server.
	PACS Server IP, Port, AE Title	PACS archive SCP Server connection settings
	Station AE Title	This workstation logical name to identify it on the PACS SCP Server
Worklist	External INI file	Set path for worklist data file generated by HIS. Default is: C:\ProgramData\NoravMedical\PCECG\Worklist\PatientFile.ini
	Query DICOM MWL	Enable and configure connection with DICOM Modality Worklist server.
	Local Copy	Set the directory path for backup copy of the worklist file to use it during HIS source system connection faults.

Table 10: Resting ECG Setup Options

STRESS ECG

(This option is available with S1 and S2 licenses)

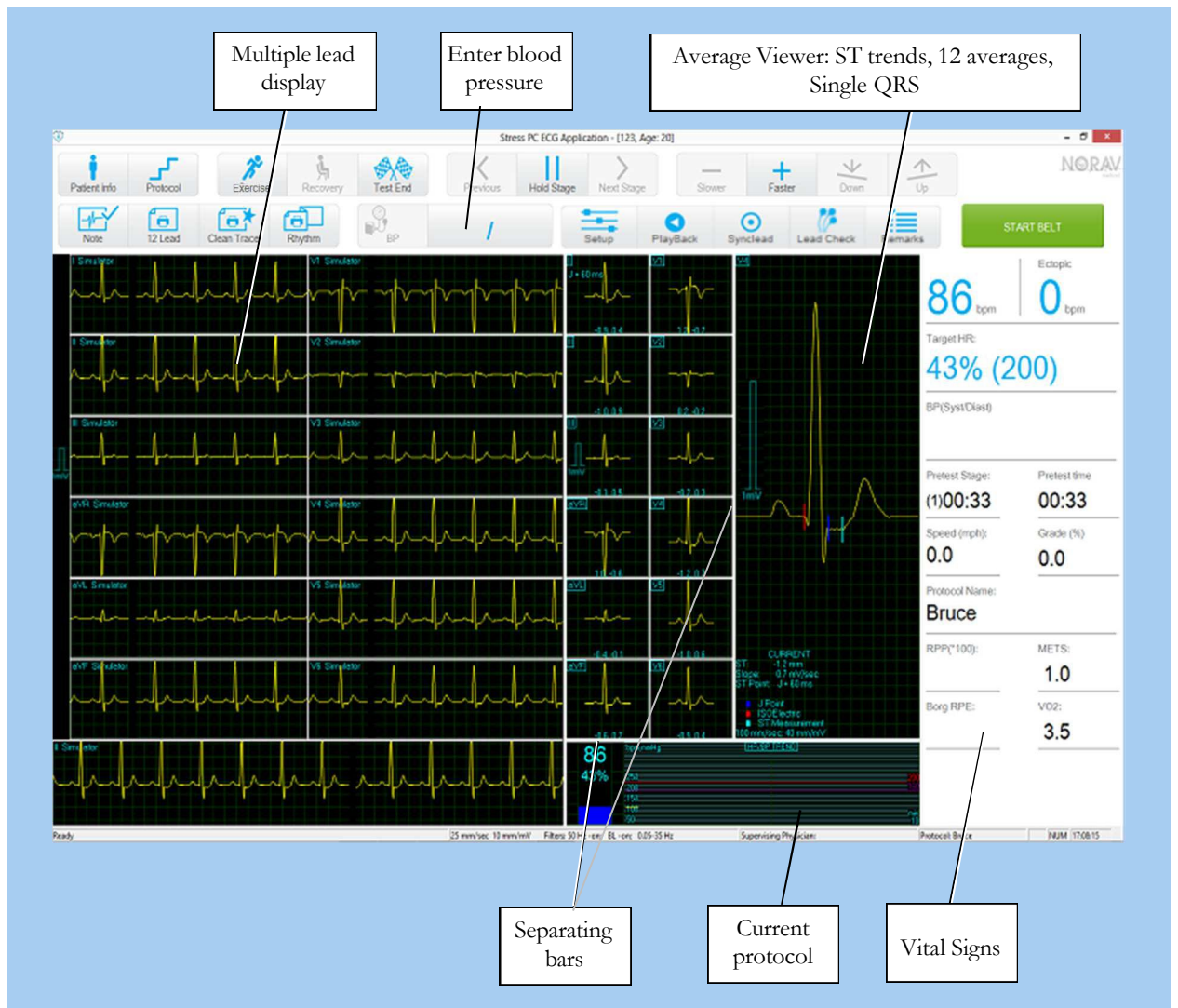

Figure 37: Stress ECG Screen

To Customize the Display

Click and drag the separating bar between two sections with the mouse cursor.

To Lock Screen Window Borders

If you want to keep the display in its present format:

Click **Setup** > **View** tab.

Check **Lock Splitter**.

Quick Start

To Perform a New Test

1. Hook up the Patient
 - a. Prepare the skin
 - b. Connect electrodes

This application uses the standard 10 contact cables. It contains four limbs (RA, LA, LL, and RL) and six chest (V1-V6) contacts. 12 derivations are recorded and displayed:

- 3 Bipolar derivations: I, II, III
- 3 Augmented derivations: aVR, aVL, aVF
- 6 Unipolar derivations: V1-V6

You can use a simpler cable with four contacts (only limbs). It produces six derivations only: three Bipolar and three Augmented.

You can place the leads on the patient in various ways. The usual method is to place the leads in the standard positions on the chest (V1-V6).

Attach the leads as shown below

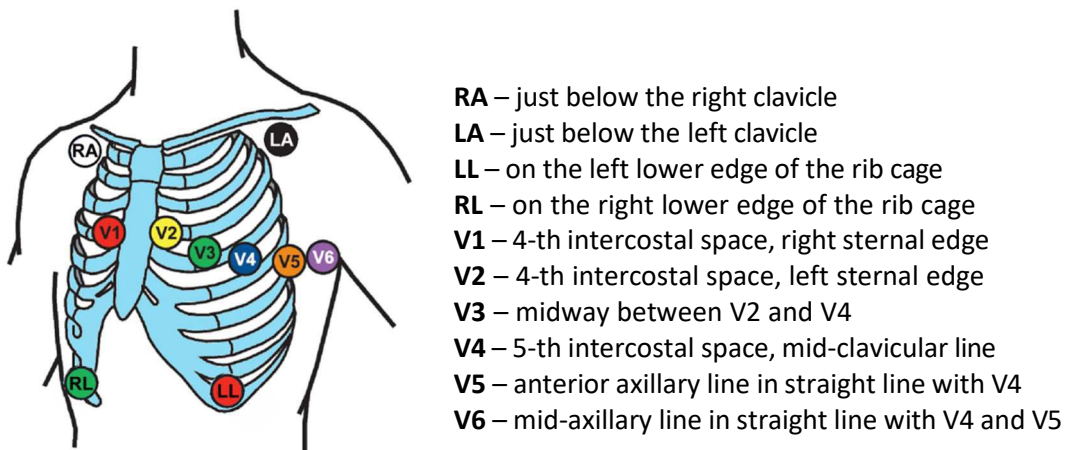

Figure 38: Stress ECG lead placement with 10-electrode cable (AAMI labels)

2. Start a new test
 - Run the Stress ECG application.
 - Initiate new test by clicking the **New** main menu button or by pressing the **F1** keyboard key.
 - Insert patient details then click **OK** button or press the **ENTER** keyboard key.
 - The Pretest phase begins.
3. Start the Exercise phase: click **F3** (or **Exercise** button).
4. Perform the examination.
5. To begin the Recovery phase: click on the **F5** key or the **Recovery** button.
6. To Stop the test: click on the **F4** key or the **Test End** button.

To Print an ECG

- Select **Print ECG** from the File menu.
- Select **Current Stage\Entire Study** from the **Print ECG** submenu.
- Select the printer from the print dialog box.
- Click **OK** to close the dialog box and start printing.

To Print a Report

- Click **Print** on the toolbar.
- Select the report/s to print.
- Click **OK** to start printing to the default printer.

Or

- Select **Print Reports** item from the File menu.
- Select the report.
- Define the printer in the Print dialog box.
- Click **OK** to start printing the report.

For an example of a printed report, see Appendix C.

Operation with Function Keys

F1	New recording
F2	Run/stop the monitoring in the Pretest phase
F3	Begin the Exercise phase of the test
F4	Stop the test
F5	Begin Recovery phase
F6	Set/print Event
F7	Hold stage
F8	Next stage
F9	Review
F10	Previous stage
F11	Open saved study
F12	Stop the treadmill in emergency

Table 11: Stress Function Keys



Note

Before using the stress test package define preferred parameters in Setup. Otherwise the program will operate according to the factory setup.

Toolbar Overview

Main Toolbar

This toolbar is displayed during the start-up. Use it to open an existing test or to begin a new one.

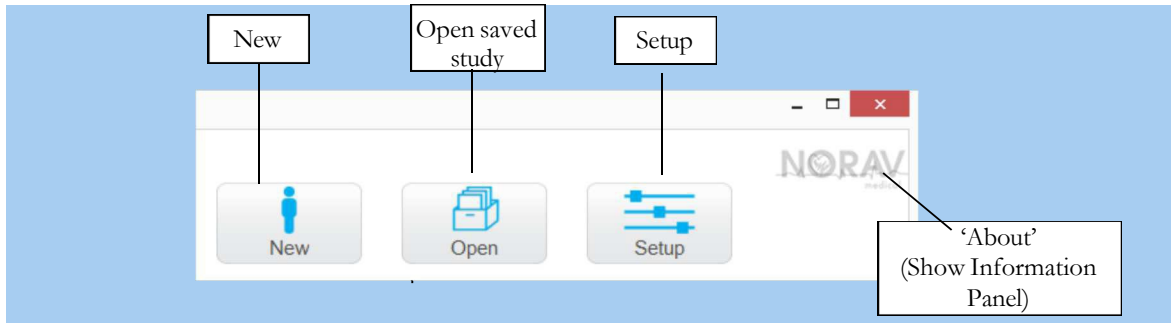

Figure 39: Main Stress Toolbar



To do this	Click this icon	Or press a keyboard key	Or select this menu	Description
Start a new study		F1	File > New	Creates a new study
Open an existing study		F11	File > Open	Opens an existing study
Setup a Printer			File > Print Setup	Set the active printer and adjust the printer settings.
Recover the ECG traces			File > Recovery File to Monitoring Format	Enables saving the ECG data if the Stress application crashes. In the dialog box, provide a name and path for the file (StrXXX*.TMP). To view the ECG then open this file with the Monitoring ECG application.
Import demographic data from EHR to PC-ECG			File > GDT/BDT Format	To start a new examination with the patient name selected in the EHR system. For details see Import from GDT/BDT
Change Supervising Physician			View->Change Supervising Physician	Opens a dialog with a list of defined physicians to enable changing the supervising physician.
Select an Exercise Protocol			View > Change current protocol	Changes the exercise protocol or swaps between the treadmill and an ergometer.
Set preferences		Ctrl+T	View > Setup	Displays the setup dialog box
To display information			Help > About Stress...	Displays program information, version number, and copyright

Table 12: Stress main toolbar and menus

Stress Test Commands

This toolbar is displayed at the start of a new test.

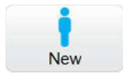
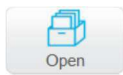
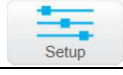
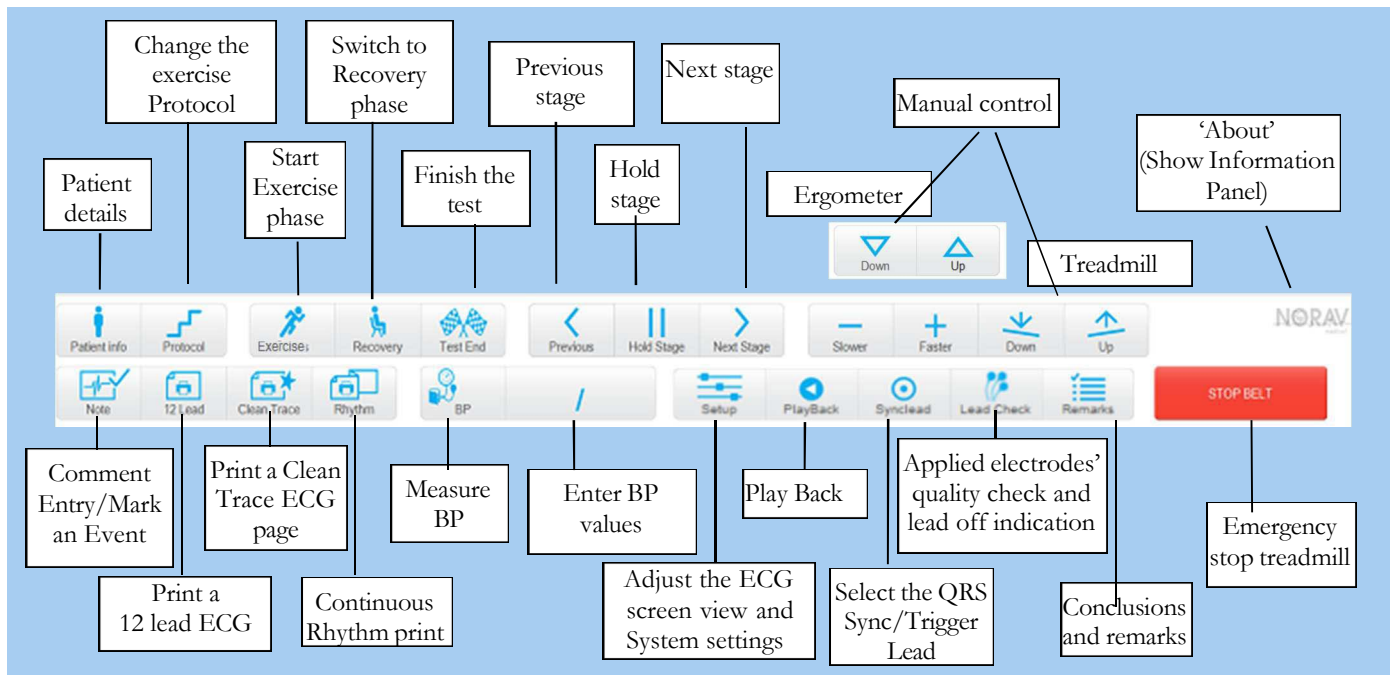

Figure 40: Stress Test Commands Toolbar

To do this	Click this icon	Or use this short-cut key	Or select this menu	Description
Start/stop the ECG recording		F2		To cancel or restart the ECG recording during the Pretest phase.
Patient information				Displays the patient information.
Change the exercise Protocol				To select the exercise protocol and to define the target HR and alarms.
Start the Exercise phase		F3		Starts the Exercise phase
Start the Recovery phase		F5		Starts the Recovery phase
Stop test/ Recovery phase		F4		Ends the stress test or recovery phase
Add Event		F6		Sets event and prints according to options
Print the ECG page				Prints ECG screen according to options
Print a Clean Trace page				Prints ECG screen with the Clean Trace median
Print the ECG Rhythm				Continuously prints ECG traces on Z-folded paper. (P1 software license is required & thermal printer required).
Measure the blood pressure				Saves the BP values entered on screen, or activates the blood pressure monitor









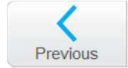
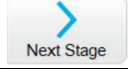
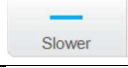
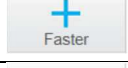
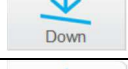
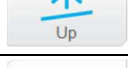
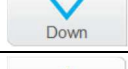

Freeze the current stage		F7		Freezes the current stage in the protocol. Click again to release the stage and continue with the protocol.
Return to the protocol stage		F7		Returns to the protocol automation.
Back to the previous stage		F10		Back to the previous stage in protocol.
Advance to the next stage		F8		Advances to the next stage in the protocol.
Slower speed				Decreases the treadmill belt speed. <i>Sets the Manual workload mode.</i>
Faster speed				Increases the treadmill belt speed. <i>Sets the Manual workload mode.</i>
Inclination down				Decreases the treadmill inclination. <i>Sets the Manual workload mode.</i>
Inclination up				Move the treadmill inclination up. <i>Sets the Manual workload mode.</i>
Power down				Decreases the workload of the ergometer. <i>Sets the Manual workload mode.</i>
Power up				Increases the workload of the ergometer. <i>Sets the Manual workload mode.</i>
Stop the belt		F12		Emergency stop of the treadmill
Start the belt		F12		Starts the treadmill belt.
Configuration		Ctrl+T		To adjust the screen layout and the system configuration.
Play back the ECG traces		Space bar key		Display and scroll back in a separate window the ECG traces recorded since the current test start.
Change the QRS Sync Lead				Changing the ECG lead for the BNC/trigger output.
Applied electrode quality check		Ctrl+Space bar key		Display the schematic torso picture to verify the applied electrodes connection quality and the lead off status.
Remarks		Ctrl+R		To enter the test remarks and comments.

Table 13: Stress Test Commands

ECG Screen View and Filters panel

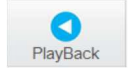
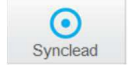
The screen view panel opens on click the **Setup** button.

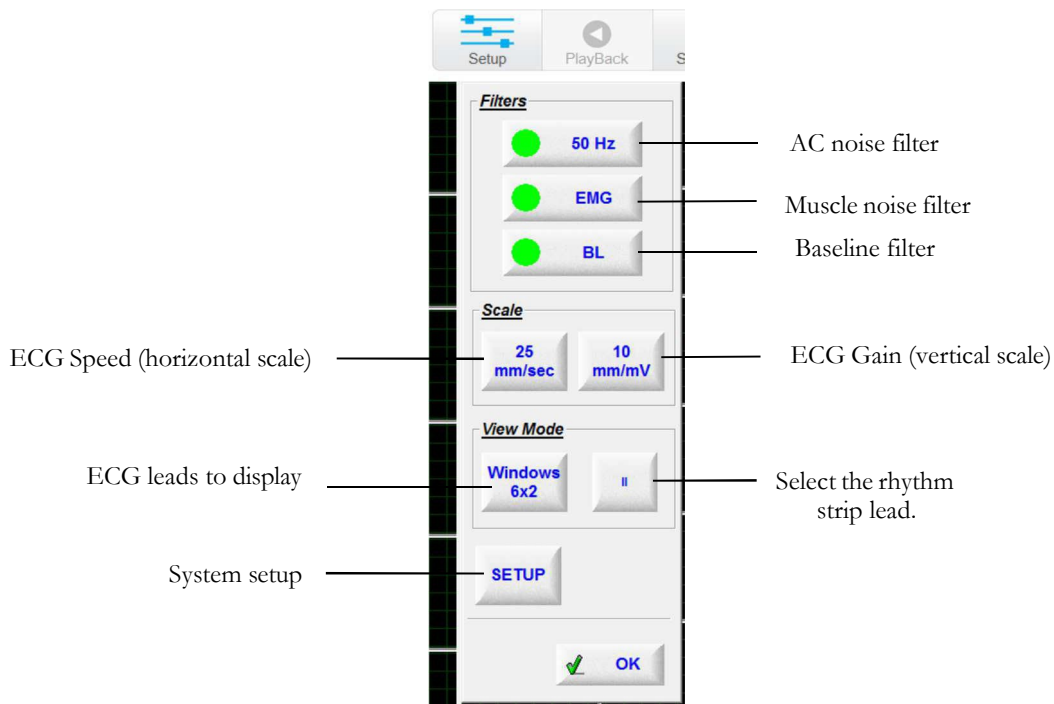

Figure 41: Stress ECG Views and Filters panel

Average Viewer Settings

The right mouse button menu is displaying various views available for the average viewer panel.

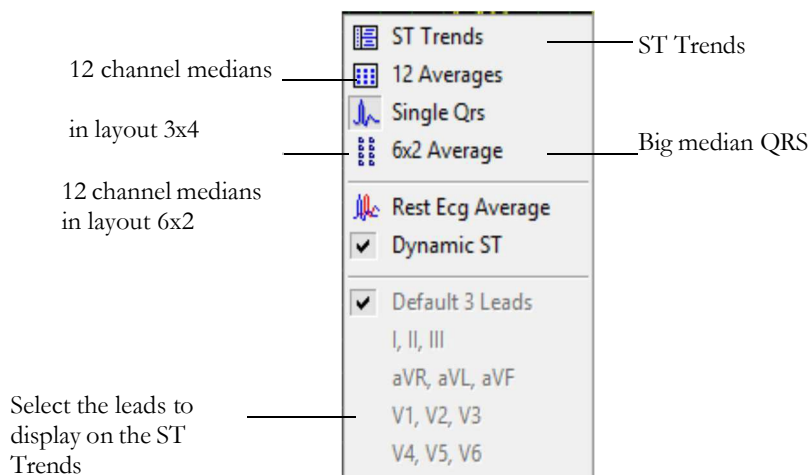

Figure 42: Stress ECG Average Viewer screen setup menu

Post Processing Options Toolbar

When the test is complete you can review it using the Post Processing Options Toolbar.

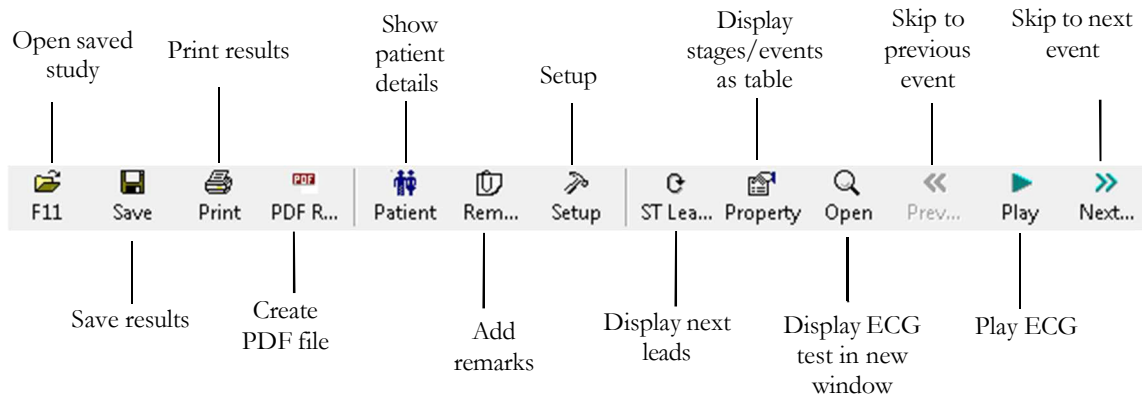

Figure 43: Stress ECG Post Processing screen toolbar

To do this	Button	Shortcut	Menu option
View 12 leads ST trends results			View > 12 Leads ST
View 3 leads ST trends results			View > 3 Leads ST
View next ST trends Triplet			View > Next ST Leads
View numerical results		Ctrl+V	View > Properties
Undo the last action		Ctrl+Z	
View ECG 10 sec data		Enter	View > Open ECG Data (requires I1 or I2 license).
Move marker to previous event		Ctrl+←	View > Event > Previous Event
Move marker left 10 sec		←	View > Event > Left
Play back results			View > Play ECG Data
Move marker right 10 sec		→	View > Event > Right
Move marker to next event		Ctrl+→	View > Event > Next Event
Add (create) a new event			View > Add New Event
Delete the current event			View > Delete Current Event
Set preferences		Ctrl+T	View > Setup
Print the study		File/Print ECG	This enables you to print the entire study or a single stage
Position the ST marker		View/Recalculate ST	This enables you to position the ST marker for the entire study

Table 14: Post Processing Toolbar and Menus

Stress ECG System Setup

Printer Definition:

Printer definition is very important because of the high data rate during real time printing. If the printer has about 8–10 MB RAM, set the graphic resolution at 600 dpi. If the printer has about 2 MB RAM, reduce the resolution to 300 dpi.

Click **Setup** on the Toolbar to access the following parameters:

Tab & Secondary Tab	Option	Description	
ECG Recording	Default filters	Defines the filter's initial status in ECG recording.	
	Save Options	Save Format	Defines the amount of data to be saved on the disk.
		Auto Save	Set this option to save the ECG test file automatically at the end of the examination..
		Set File Name by	To save the recording file name by Patient ID or Patient Last Name.
	Simulator ECG	When cleared (default), the ECG acquisition is performed from the PC-ECG unit. When checked, the ECG recording is performed from the demo waveforms included in the software package. In this case, the recording unit is not needed. On leads display (and on reports) the word "Simulator" will appear	
	Alert signal OFF	There is an alert (beep) when HR reaches the Max. predicted HR or Target HR. If this option is marked, there is no alert.	
	Beep on QRS	When marked, beep is heard every time QRS is detected.	
	ECG Leads	When using the standard 12 lead patient cable, select the 12 Leads option to read and display up to 12 leads (default). When using a 6 lead cable ("LIMB leads"), select the 6 Leads option.	
	Sample Rate	Allows the user to choose the ECG acquisition sampling rate.	
	Use ECG Database	Select this option to connect to the NEMS database (optional).	
Data Directory	To define a directory for saved ECG recordings (if NEMS database is not used, otherwise the data directory is defined in NEMS system).		
Leads	Default 3 leads	Specifies the 3 leads that are displayed as default when using 3x1 view format.	
	Default 6 leads	Specifies the 6 leads that are displayed as default when using 6x1 or 3x2 view format.	
	Strip Lead	10 sec lead to appear in 4x3 and 6x2 formats.	
View	Default Colors	To specify the screen colors for background, ECG traces, graphs and text. Click the appropriate button and select the color from the color palette.	
	Default ECG View	Select default on screen lead display from the list in the combo box. Separately configures the main ECG screen and the Playback window.	
	Horizontal scale	Sets the default value for the horizontal scale window on screen (mm/sec).	
	Vertical scale	Sets the default value for the vertical scale window on screen (mm/mV).	
	Real Time Average QRS	Select Static or Dynamic (worst case ST) to display Average QRS. If Static option is selected, the Average QRS displayed is of the default strip channel selected in the setup. If Dynamic option is selected, the channel of the displayed Average QRS dynamically changed according to the channel with the worst case ST.	

Tab & Secondary Tab	Option	Description
View	Show Baseline QRS	Check this option to keep on screen the baseline QRS average during the whole test including Pretest, Exercise and Recovery phases.
	Separate Leads	Check this option to have the leads separated by borders.
	Draw over lead borders	Check this option to not cut off a high signals exceeding the channel display drawn beyond the lead border.
	Draw Grid	Check to display grid lines. Uncheck to hide gridlines.
	1 mm Grid	Check to display grid with 1 mm resolution, otherwise the grid cell resolution will be 5 mm.
	Cabrera display	Check this option when using a Cabrera layout of ECG leads. When using the standard lead system, clear this option.
	Lock Splitter	When this option is checked, the window splitters cannot be moved and the sections in the viewer cannot be resized. To resize the different sections in the viewer, clear this option.
	Smooth ECG Trace	Check this option to display a smooth ECG trace on the screen. Default: Enabled.
	Clock count up	Check this option to set the time from beginning of the current stage (count up). If not checked, the time displayed is the time left until the end of the current stage (count down). The default: not checked.
	Monitoring-only the first stage Pretest	If enabled, the very first stage in Pretest is suggested for hook-up check and it does not appear in the Tabular report.
	Count Recovery time separately	Check it to define separate timers for Exercise and Recovery phases. If not checked, the time displayed on screen in Real time and in Review is the overall time including both Exercise and Recovery.
	Show the worklist	When enabled, on start new test the worklist appears raiser than patient details panel.
	Calculate Body Surface Area	Displays the estimated body surface area. Available methods: Mosteller, DuBois, Haycock, Gehan, Boyd.
	Draw Pacer	When enabled, an artificial marker (vertical dashed line) replaces the detected pacemaker spike on the ECG trace on screen and on printout. If the option is not enabled (default), pacemaker spike is shown as is. Note: this artificial marker is relative of time but is not representative of either pacemaker' pulse real amplitude, polarity or width.
	View 1 mV calibration pulse	If cleared, the 1 mV pulse will appear only in printing. If checked, the 1 mV pulse will also appear on the screen.
	Enable Lead OFF Alarm	Enable the alarms for ECG electrodes disconnection
	Audible Lead OFF Alarm	Enable the audible alerts for Lead OFF alarms
	Easy Toolbar mode	Check this option to display fewer icons in Review screen
	Text Labels	Displays text labels on toolbar buttons in the Review screen
	Vital Signs	Select additional parameters to display in real-time: Max. predicted HR or Target HR, Speed,Grade/Power/Dose, SpO2, Protocol name; RPP, METS,VO2, PWC, Borg score, Distance, Target-Watt max
	Ergometer METS/Watt	Applies to an Ergometer test. The selected units (METS or WATT) are displayed for the Workload on the Review screen and on printout.
Summary Review Mode	Mark the appropriate check box to automatically show remarks, results table and ECG preview upon opening the record for Review	

Tab & Secondary Tab	Option	Description
Installation		Saves an organization name, address, logotype and a workstation (modality) name. This data appears on printout and on PDF report.
	Supervising Physician	Add/Edit/Remove a Supervising Physician' name, password and personal signature stamp to list. Select from list and set as Default Supervising Physician.
	Technician	Add/Edit/Remove a Technician' name to list. Select from list and set as Default Technician.
	Referring Physician	Add/Edit/Remove a Referring Physician' name to list.
	Measurement Standard	Define whether measurements will be calculated according to the metric or the USA standard. Default is metric .
Environment	ECG Connection	Select amongst COM port, USB or Bluetooth to choose the port for the PC-ECG acquisition device.
	Display Size	This setting is required in order to display the ECG and grid in the correct scale.
	Toolbar buttons	Adjusts the toolbar buttons size. Choose Small option for 768 pixels, Medium for up to 1080, Big for up to 1200, and Huge for >1200 pixels of PC screen' height.
	Measure BP by Automatic Device	If a blood pressure monitor is used, define whether automatic measurements should be performed in addition to manual measurements.
	BP Measurement Mode	Set the BP measurement method. Choose between Auto, Auscultatory or Oscillometric modes.
	BP Port	Set the Port that the BP device (optional) is connected to.
	SpO2 sensor	To choose the optional device for SpO2 measurements.
	Check NET Key	Check this option if the software license is installed on network located key (NetHASP).
Profile		Enable the examination test profiles, assign COM ports and define the stress protocols.
	Exercise Device	Select a model of the Treadmill and the Ergometer. The type should be assigned separately for treadmill and for ergometer.
	Default protocol	Stress protocols list. Choose one of the available protocols or define your own protocol. Default Protocol should be assigned separately for treadmill, ergometer and pharmacologic profile.
	Speed unit	Set up for MPH or KPH . This option refers to treadmills only.
	Emergency STOP	Select the procedure for Emergency STOP of the treadmill. Select Immediately for abrupt stop of the treadmill or Slow Down for gradually slowing down the treadmill until final stop.
	Manual control step	Refers to ergometers only. Determines the load increment step while manual controlling of the ergometer.
Advance	QRS Sync Output	Valid for S2 Advanced Stress option. ECG Trigger settings for devices with analog output built-in (1200HR and 1200W models). <ul style="list-style-type: none"> - Check the R wave trigger option when using USB connection with BNC/trigger output if a blood pressure monitor is used or if external synchronization for imaging is needed. Select the required R-wave trigger width from the option list. - or check the ECG option for analog ECG signal.. - select the Default Lead for BNC/trigger output. - Check the In-Test "Sync Lead" Selector to show the BNC lead selector on the main tool bar. This option permits online changing of the BNC/trigger output lead during the examination.

Tab & Secondary Tab	Option	Description
	Analog Out 1/Analog Out 2	1200W wireless ECG device analog outputs configuration. Valid for S2 Advanced Stress option. - select the ECG Lead for analog ECG output. - or select the Heart Rate option for the heart rate analog signal. - or select the Analog Control for analog controlled ergometer/treadmill.
	Cards	Configuration for the D1-T D/A board, used if a TTL Trigger output or analog out is needed for ECG devices without analog output built-in (for models 1200S, NR-1203-E and 1207-3).
	Metabolic Interface	Valid for S2 Advanced Stress option. Check this option to enable the “HR as Linear Analog Voltage” signal on a secondary BNC output. An additional 1200USB-A adapter is required.
	Use Transfer file “Trnsf.txt”	Check this option to export the ECG exercise real-time data such as HR, Workload and other through the Trnsf.txt file. Read the “ Transfer File Trnsf.txt ” chapter for details.
	Use real time protocol export file	Check this option to export ECG exercise real-time data through the ERGOSPIR.DAT format file. Applicable to communication with external CPET/CPX system or to other compatible system. When checked, the path and file name should be defined. (Default path: C:\LAB5\DB\ERGOSPIR.DAT)
	Slave mode operation via external control file	To enable the Slave operation mode. Applicable in conjunction with external CPET/CPX system or to other compatible system. When checked, the control file name and path should be defined.
Printouts	Auto Print Default Reports on End Test	Check this option to automatically print the default reports at the end of each test.
	Default Reports	Specifies the final reports set.
	ECG Pages	Specifies 12-lead ECG printouts to be included in the report set
	Use Large fonts for Remarks	Enlarge the font for user entered free text comments.
	Shadow/Frame for Area of Interest	Allows the user to choose a shadow or frame to highlight the area of interest.
	Print Event Remarks	Collects all events comments text in the Conclusions field of the Comprehensive report
	CleanTrace Printout	Check this option to apply the CleanTrace filter to the 12 lead ECG printouts issued offline (in Review screen).
	ECG Line	Define the line width in the printouts, either Normal or Bold.
	Leads Print	Simultaneous (default) prints the simultaneous segments of ECG data for each of the leads synchronised with time point of the frame on a full 10 seconds bottom strip. The term “simultaneous” refers to the fact that the data presented for each lead taken at exactly same time. Successive report shows a sequential sample of ECG data from each of the 12 channels. Each successive channel has the next time zone of ECG data of the total of 10 seconds of data. The beginning of each channel is marked by a vertical line and the channel identifier in bold letters. The bottom trace on the graph features ten seconds of data. It also serves as a time stamp for the entire report. Each QRS complex in this trace is the same on found in other traces above it.
Event Format	Set Event format for printout to either 3 lead or 12 leads format.	

Tab & Secondary Tab	Option	Description
	Tabular Results	Values: Select Events only , All or Every 1 minute option to print out the results format in a tabular format. Format: select Remarks to print comments on this page or select the ST Values to print complete the ST measurements table instead
	Trends	Select Remarks to print comments on the right side of the page or select the ST Values option to print here the ST trends instead.
	Graph Paper	When enabled, prints 1 mm and 5 mm grid on printouts. Option Regular Grid works with any printer. Option Improved Grid shows a fine grid but may not work on some printers.
	Color Printout	Select this option for colored printouts.
	Blending out ST values	Select this option to print results without ST values.
	Rest Event	Select Interpretation and/or Measurements to display Interpretation and/or Measurements on Rest stage printout.
Worklist	Source System	Select and configure the source for read the worklist items. Choose between connecting to DICOM Modality Worklist server or read patient names from the external INI file
	Local Copy	Defines the local directory for save the backup copy of worklist items
GDT/BDT Format	Automatic Options	Setup automatic options for saving and/or importing files in GDT/BDT format.
	File Format	Select the file format: GDT or BDT.
	Import Codepage 437	Check this option to import Code page 437.
	Export Codepage 437	Check this option to export Code page 437.
	Edit Labels	Click this button to open a dialog box with an editable list of the field labels used in the GDT and BDT files.
	GDT/BDT Data Directory	Specifies the directory path where the GDT/BDT files should be maintained.
	Token for PCECG	The default is PEKG .
Token for Practice EDP	The default is EDV1 .	
Text File	Auto Save Test Data in Text File	Check this option to save the test data automatically to a text file at the end of the test (according to the naming and directory defined in this tab).
	Set Text File Name by	Define the naming convention of the text file, created automatically or on demand.
	Text File Data Directory	Specifies the directory where the text files will be maintained.
PDF/XML /DICOM/RDT	Auto Save test Data in PDF format	Check this option to save the test data automatically to a PDF file at the end of the test (according to the naming and directory defined in this tab).
	PDF Reports	Specifies the pages to include in the PDF report.
	Auto Save test Data in XML format	Check this option to save the test data automatically to a XML file at the end of the test.
	Set PDF/XML/RDT File Name by	Define the naming convention of the PDF, XML and RDT file, created automatically or on demand.
	Delimiter	Select the delimiter character between the data values in the formatted filename of the PDF and XML files.
	ECG Grid in PDF	Specify the printed grid color in PDF report: B&W or Color Grid
	XML File Format	Define file format as HL7 XML, Cardiology XML or Clinical Report.

Tab & Secondary Tab	Option	Description
	PDF/XML File Data Directory	Specifies directory where the PDF and XML files will be maintained.
	RAW DATA File Format	Specifies parameters for export the ECG in RAW data format
	DICOM	Enable and configure the export of study reports to the DICOM enabled systems
Target HR/METS	Max. predicted HR	Set the maximum HR for to be allowed for use in the Max. predicted HR equation which is affected by the age and gender of the patient.
	Target HR (%)	Set the percentage of Max. predicted HR for Target HR. Above this level, the HR trend is displayed in a different color. If the percentage value is reached during the test and Switch to Recovery when reaches Target HR option is checked, the stress test stops automatically and recovery phase begins.
	Audible HR Alarm	Enable the audible alert for the High HR and Low HR alarms.
	Stop Stress and start Recovery	Check this option to stop stress test when HR reaches the Max. predicted HR or Target HR and start the recovery phase. When Switch to Recovery when reaches is cleared, the Stress test continues according to the test protocol.
	Max HR lookup area	Determine phases to search for the Max HR value. User can exclude Pretest or Recovery phases from the Max HR search.
	METS/VO2 Formula selection	Set the formula to calculate the METS/VO2 values: <ul style="list-style-type: none"> - to use a single formula check the Single formula for any speed. - to use one formula for speed up to 3.7 mph and a second formula above that speed, set the option Two formulas (up to and from 3.7 mph).
	METS/VO2 Updating Method	Select the method for updating the METS/VO2 values. The values can: <ul style="list-style-type: none"> - remain constant through the entire stage - switch to the current METS value 1 or 2 min. after the stage begun - have values vary during the stage (at every quarter of the stage time).
	Borg Scale	Rating of Perceived Exertion Scale. Select the CR10 or RPE scale. Define the anaerobic threshold value in Target RPE scroll box.
	Blood pressure limits	Enable BP alarms and define the alarm thresholds.
	Risk Assessment	Enable the Duke Treadmill Score risk assessment feature
ST. VPB, SpO2 Options	ST Measurements After J	Choose the number of milliseconds after the J point at which the ST is measured. The factory set up is 60 Ms.
	Detect ST Event	Define the mm level for elevation and depression. This option also allows the user to save only deteriorated ST episodes.
	Worst case ST Report	Select ST Elevation, ST Depression or both to be reported as Worst case ST.
	Lookup area	Determine phases to search for the Worst ST value. User can exclude Pretest or Recovery phases from the Worst ST search.
	Arrhythmia Detection	Select the arrhythmia event types to be detected and stored. Check the Store one event per stage only option or clear this option if you wish all selected event type to be stored.
	SpO2	Enable and define the threshold for Low SpO2 event detection.
Real Time	Printing	Set the events to print automatically (including stage ends, ST, Arrhythmias, BP, SpO2 and timed events).
	Show Dialog	Check events to display a dialog box at the beginning. Clear events to prevent display of dialog box.
	Print Page Format	Check the required option for printout format.

Tab & Secondary Tab	Option	Description
	Enable CleanTrace	Activates the synthesized ECG rhythm print option.
	Print Scale Format	Select the scale for printout format.
	ST, Slope Printing	Select this option to put on printouts the ST and ST slope values.
	Enable Rhythm Print	Activates the Rhythm button for continuous ECG printing option`.
	Use last saved BP value during the stage	Select this option to continue to use the same BP value that was last saved. When not selected, the last BP value will not be used.
	Switch to Review automatically	Check this option to switch automatically to the Review screen at the end of the test. When cleared, the real-time screen remains
	Constant Time BP measure	Check this option to automatically measure BP at time intervals (separate timers for Pretest, for Exercise and for Recovery phases).
	BP Alarm Time	Set this parameter to receive a reminder to take BP at selected time before the end of every stage in the exercise phase of the examination
	End of stage Alert	Specifies the time before the end of stage the alert should start
	Print User Event	Select 5 sec Prior and 5 sec Post Request or 10 sec Prior to set the time of ECG printed in reference to the time the Print button is pressed.
Remarks		Defines statements that can be entered during the test and offline.
Remote View		Valid for option S2 . Enables viewing a study that takes place in any of the network stations, across the whole network. Enables a physician to view a study remotely.

Table 15: Stress ECG Setup Options

Perform the Stress ECG examination

Launch the Stress ECG software application. The initial screen is displayed.

To Start a New Test

- Click on  main menu button or press the **F1** keyboard key.
- The Stress working screen and patient data entry screen are displayed.

Figure 44: Patient Data Entry



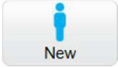

- Enter patient data and click **OK**. Monitoring of 12 leads begins. After about 15 sec the average QRS is displayed.
- Use the  button to verify the applied electrodes connection quality.
- If necessary, click on  icon to change the exercise protocol, swap between the treadmill and ergometer or adjust the target HR and other alarms.

Figure 45: Change the Exercise Protocol

- Enter blood pressure.
- You can print a baseline ECG page using the  icon.
- To start the exercise session click on the  icon (**F3**). The exercise time is displayed in the vital signs panel on the right side.

The following options are available during the exercise phase:

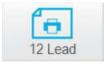
- ◇ Define and print events.
- ◇ Print the ECG screen and continuous Rhythm.
- ◇ Manual control of the treadmill/ergometer.
- ◇ Manage the protocol stages: Hold stage, Advance stage, Previous stage.
- ◇ Change the exercise protocol in the middle.
- ◇ Go to Recovery phase.

PlayBack display

During a Stress test at real time a period of any 10 second period of the recorded ECG can be viewed in a separate window. This option is enabled 10 seconds after the beginning of the stress test (available only with the **S2** software key option).

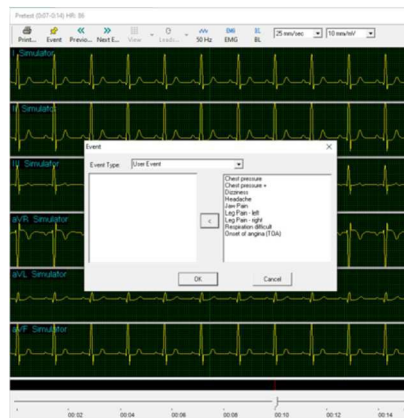





Figure 46: PlayBack Window

- a. To open the PlayBack window press on  or on the space-bar key.
- b. Navigate with the scroll bar or keyboard arrow keys to the requested time.
- c. Or use the  buttons to navigate through detected arrhythmias and user events.
- d. Click  button to define new Event.
- e. Press again on **Playback** or on space-bar key close the Play Back window.









To do this	Click this icon	Description
Print the ECG page		Prints the current ECG screen (automatically creates new Event)
Mark new Event		Defines new Event mark
Event and stages Navigation		Go to previous or next event mark
Set the screen layout		Setup the ECG traces layout
Select the strip lead		Changes the strip lead
ECG Filters		Enable/disable the ECG filters
Horizontal scale		Adjust the speed of ECG traces (speed)
Vertical scale		Adjust the gain of ECG traces (gain)

Table 16: PlayBack window Toolbar

Recovery Phase

When the Exercise phase is completed the Recovery phase begins automatically. Press

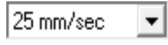
the  icon (**F5**) to switch to recovery phase at any time during the Exercise phase. The recovery phase elapsed time is counted as well as the total elapsed time. Wait for the recovery phase to finish according to the protocol or stop it using the

 icon (**F4**). Both the TEST and RECOVERY times are finalized. Data is no longer acquired for this test.

There are two options for completing a stress test.

- Display the post-processing data screen (Review Screen) automatically
- Remain in ECG display.

To Display the Review Screen Automatically

In Setup, click the **Real-Time** tab and check **Switch to Review Automatically**.

At the end of the test protocol, or after clicking  icon (**F4**), the display switches automatically to the Review Screen, and the post-processing information is displayed.

To Display the Review Screen Manually

If **Switch to Review Automatically** is not enabled in setup the ECG signal continues to run after the test end.

- To open the Review Screen press **F9**.

Viewing Results

Viewing results are available in Review Screen after finish the examination.

The Review Screen is displayed with the post processing data. It provides the following options:

- ◇ Validate and edit the examination results such as HR, ST, BP, SpO2 etc.
- ◇ Write conclusions.
- ◇ Display, save and print ECG traces.
- ◇ Print reports.
- ◇ Perform ECG Measurements (optionally).
- ◇ E-mail the examination results.
- ◇ Generate reports in PDF format (optionally).
- ◇ ST Reanalysis.

To Save Study Results

- Click **File > Save**, define the file name and path, and click **OK**.

Understanding Target Heart Rate in Stress Test

Resting Heart Rate

Measured during the patients resting phase, typically is between 60 and 100 bpm.

How to measure Resting Heart Rate

- Monitor with ECG device in the Resting Stage of Stress.
- May be measured manually. Count the number of beats in a minute, this is resting HR.

Maximum Predicted Heart Rate

Most commonly used formula is age subtracted from 220.

Target Heart Rate

Expressed in a percentage, usually is defined between 50 % and 85 % of the maximum predicted safe heart rate (see example below).

Example: 58 y/o male

MAX Predicted Heart Rate: 162 bpm (220 - 58)

50% exertion level would be 81 bpm (162 * 0.5=81)

85% exertion level would be 138 bpm (162 * 0.85=138)

The target heart rate that a 58-year-old would be 81 to 138 beats per minute.

Metabolic Stress Estimation (METS)

A very important feature of the software is the estimation of Metabolic Equivalency (METS). This estimates how many ml of oxygen the body produces for every kg of weight per minute. The results are shown in units of METS or VO2 Max. (One unit of VO2 is 3.5 units of METS.)

1 METS corresponds to a person at rest.

A higher METS indicates a higher fitness level.

Transfer File “Trnsf.txt”

Use this option when the PC-ECG 1200 shares the same PC with another application in real time.

To Transfer a File

- Click **Setup > Environment**.
- Click the **Advance** tab.
- Check the **Use transfer file “Trnsf.txt”** option.

A transfer file is created in directory containing the Stress application program data. The default is C:\ProgramData\NoravMedical\PCECG\. The transfer file receives real time data from the Stress application, such as: current Heart Rate, Workload, Speed, and Grade, walking distance, RPM, blood pressure and SpO2. It is a text file, updated every 1 second.

The format is as follows: Each text line starts with a descriptive header and a parameter that always starts at character number 13. The value of each parameter may change during the study.

Parameter	Value Example	Range	Units	Remark
System :	Treadmill	Treadmill, Ergometer		Exercise examination system
Protocol :	Modified Bruce			Exercise protocol name
Phase :	Exer	Chck, Base, Warm, Exer, Cool, Reco, Stop		Exercise protocol phase name
Speed :	3.3	0 to 25.0	mph	For treadmill only
Grade :	10.5	0 to 30.0	%	For treadmill only
Distance :	1.201	0 to 100.000	mile	For treadmill only
Workload :	120	0 to 1000	watt	For ergometers it is measured. For treadmills it is estimated by formula: $\frac{\text{BODYWEIGHT} \times 9.8 \times \text{SPEED} \times 0.447 \times \text{GRADE}}{\sqrt{(10000 + \text{GRADE} \times \text{GRADE})}}$ <i>(SPEED in mph, GRADE in percent, BODYWEIGHT in kg)</i>
RPM :	47	0 to 300	1/min	For ergometer only. Rotation/min
HR :	86	0 to 300	bpm	Heart rate
Systolic :	203	0 to 300	mmHg	Systolic BP
Diastolic :	78	0 to 300	mmHg	Diastolic BP
ST :	-7.3	-20.0 to 20.0	mm	ST segment deviation. <i>(for most significant ECG lead)</i>
Slope :	78.8	-100.0 to 100.0	mV/sec	ST segment slope <i>(for most significant ECG lead)</i>
SpO2 :	97	0 to 100	%	In %. Blood oxygen saturation

(?? value appears in case of error, out of range or if parameter is n/a)

Table 17: Transfer File Format

Export the exercise protocol real time values

Use this option when the Stress ECG shares the exercise protocol measurements with another application in real time. The protocol data stored to single line text file.

To enable the exercise protocol export file feature

Click **Setup > Environment**.

Click the **Advance** tab.

Check **Use real time protocol export file**

Insert the export file full file name including directory path.

An export file is created in the specified directory. The export file receives real time data from the Stress application, such as: stage Name, exercise device type (Treadmill or Ergometer), Speed or Workload, Grade or RPM, Heart Rate, Blood Pressure, ST value and slope. It is a text file, updated every 1 second.

Export file format

[AAAA~BBBB~C~DDDD~E~FFFF~GGGG~HHHH~IIII~JJJJ~KKKK~LLLL~MMMM~JNNPP

(where a space is shown as “~”)

AAAA – combined Phase and Stage name

“**Chck**” – initialization

“**Base**” - base phase (Resting stage)

“**Warm**” – warming phase (pre-test manual warming stage)

“**Exer**” – exercise phase (stress stages)

“**Reco**” – recovery phase (all recovery stages)

“**Stop**” – finish of test (post processing, no ECG running)

BBBB – value for **Load Parameter 1**

C – designator for Load Parameter 1

M – treadmill Speed in [0.1 mph]

K – treadmill Speed in [km/h]

W – ergometer Load [Watt]

DDDD – value for **Load Parameter 2**

E – designator for Load Parameter 2

% - treadmill Grade in [0.1 percent]

U – ergometer revolutions in [1/min] = [RPM]

FFFF – Heart Rate in [bpm]

GGGG – Ventricular Ectopic beats per minute (not used, always ~~~0)

HHHH – BP measurement NBR (not used, always -999)

IIII – Systolic BP in [mmHg] (-999 if unavailable)

JJJJ – Diastolic BP in [mmHg] (-999 if unavailable)

KKKK – ST Level for most significant ECG lead in [0.01 mV] (-999 if unavailable)

LLLL – ST Slope for most significant ECG lead in [0.01 mV/s] (-999 if unavailable)

MMMM – ST Integral for most significant ECG lead (not used, always -999)

NN – rightmost 2 ASCII characters of checksum expressed hexadecimal in UPPER CASE

PP – fixed string “CR” for Carriage return

Example 1: connect the Norav Stress ECG to CareFusion LAB 5 CPET system

In **Norav Stress ECG** setup:

Advanced panel of **Environment** tab

Insert “**C:\LAB5\DB\ERGOSPIR.DAT**” for export file name

GDT\BDT tab

- enable the **Import from GDT\BDT** check box
- insert the “**C:\LAB5\DB**” path for GDT\BDT Data Directory
- insert “**Hell**” text to **Token for PC-ECG** field

In **CareFusion LAB5 CPET** system setup:

- select **Extern ECG** for Oxycon Configuration Tool.
- perform “**Service-Login**”.
- open Settings and select **Norav** from the **ECG-Type** list.
- in **Path and program name** field select the **Stress.EXE** application executable name with full path.
- insert “**Stress**” in **Title: Use the text in ECG application** field
- insert “**C:\LAB5\DB**” in **Path: When ECG is not located ...** field.

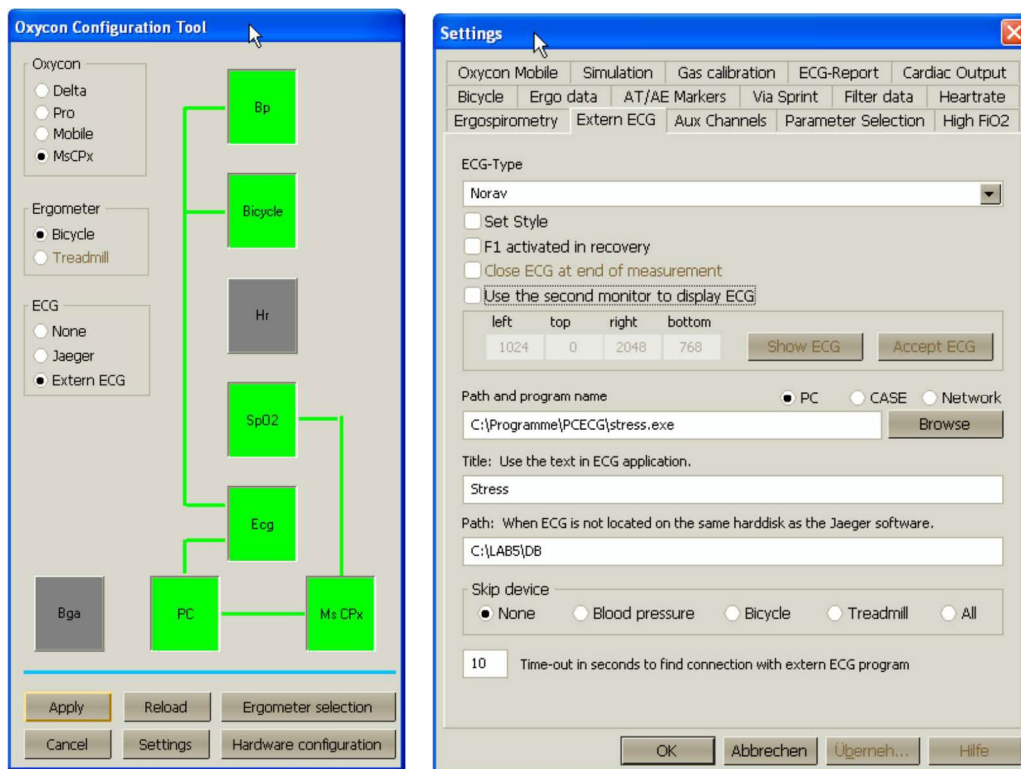

Figure 47: CareFusion LAB5 CPET Settings

Example 2: connect the Norav Stress ECG to MetaSoft®Studio v4.6.0 CORTEX CPET system

In **MetaSoft®Studio v4.6.0 CORTEX** toolbox:

- select "**Test Equipment/Device Configuration**" and add a **Norav ECG**.
- select "**Special Settings/Software Interfaces/ECG Systems/Norav**" and configure a data file directory. Make sure this does not contain spaces and is writable by the user who runs Norav Stress.exe and Metasoft. For instance: "**C:\CORNOR**". Save and quit the toolbox.

In **Norav Stress ECG** setup:

GDT\BDT tab

- enable the "**Import from GDT\BDT**" check box
- configure the "**GDT\BDT Data Directory**" to be the same as data file directory from step "**b**" in MetaSoft®Studio setup above. For instance: "**C:\CORNOR**"
- insert "**HELL**" as "**Token for PC ECG**"
- insert "**MSS**" as "**Token for Practice EDP**"

Advanced panel of **Environment** tab

- enable the "**Use real time protocol export file**" check box and type for the **ERGOSPIR.DAT** communication file location the same directory name as for the GDT interface selected above. For instance: "**C:\CORNOR\ERGOSPIR.DAT**"

Working (for every single patient examination):

- **Initial state:** MetaSoft®Studio is **opened**, Norav Stress ECG is **closed**
- **Start the Norav Stress ECG** from the desktop shortcut.
- In the **MetaSoft®Studio** select a workflow then proceed to "**Perform CPET**" view
- The Stress ECG application switches to monitoring mode automatically.
- From now, the test is controlling by Stress ECG application.
- At the end of the CPET test **exit the Stress ECG program**.

Slave operation mode

Use this option when the Stress ECG system works in conjunction with another equipment, for instance to perform the cardiopulmonary exercise testing (CPET/CPX), where the treadmill/ergometer, BP etc. hardware and the examination phases/stages are under control by the external system. The functionality is implemented via the external file generated on the external system side.

To enable the Slave operation mode

Click **Setup > Environment**.

Click the **Advance** tab.

Check **Slave mode operation via external control file**

Insert the control file full name including the directory path.

On initiate new test, the external system will constantly update the control file with the real time data. The Stress ECG application reads the control file and updates the information on the vital signs panel.

Control file format

[AAAA~BBBB~C~DDDD~E~FFFF~GGGG~HHHH~IIII~JJJJ~KKKK~LLLL~MMMM]NNPP

(where a space is shown as “~”)

AAAA – combined Phase and Stage name

“**Chck**” – initialization

“**Base**” - base phase (Resting stage)

“**Warm**” – warming phase (pre-test manual warming stage)

“**Exer**” – exercise phase (stress stages)

“**Reco**” – recovery phase (all recovery stages)

“**Stop**” – finish of test (post processing, no ECG running)

BBBB – value for **Load Parameter 1**

C – designator for Load Parameter 1

M – treadmill Speed in [0.1 mph]

K – treadmill Speed in [km/h]

W – ergometer Load [Watt]

DDDD – value for **Load Parameter 2**

E – designator for Load Parameter 2

% - treadmill Grade in [0.1 percent]

U – ergometer revolutions in [/min] = [RPM]

FFFF – Event command

None – no event created

Save – create the 10 s ECG Event

GGGG – VO₂ value in [ml/min] (-999 if unavailable)

HHHH – METS × 100 value (-999 if unavailable)

IIII – Systolic BP in [mmHg] (-999 if unavailable)

JJJJ – Diastolic BP in [mmHg] (-999 if unavailable)

KKKK – SpO₂ value in 0.1 % (-999 if unavailable)

LLLL – time gap in seconds since the test start, HEX value (-999 if unavailable)

MMMM – reserved (always -999)

NN – rightmost 2 ASCII characters of checksum expressed hexadecimal in UPPER CASE

PP – fixed string “CR” for Carriage return

Additional Features

To Define Max. HR

- Open a test in a Review Screen (post processing).
- Click **Properties** on the toolbar. The Properties dialog box is displayed.
- Select the cell with the highest HR value.
- Click **Define Max HR**.
The cell is highlighted and the background color of the cell is changed.

To Define Worst ST

- Open a test in a Review Screen (post processing).
- Click **Properties** on the toolbar. The Properties dialog box is displayed.
- Select a cell in one of the channels with the worst ST.
- Click **Define Worst ST**.
The cells in the 12 channels of the same event are highlighted and the background color is changed.

“Dynamic ST” function

This feature automatically displays the lead with the current worst ST in the Average QRS display on the upper right hand side of the screen.

To enable this function:

- In **Setup** choose **View** and at the bottom in **Real time Average QRS** select the **Dynamic** (Worst Case ST).
- Go to **ST, VPB Options** and select needed option for the **Worst Case ST Report**.

“Clean Trace” function

A synthesized ECG rhythm printout in which median beats are filtered and linked creating a cleaner tracing that is accurate. On the bottom of the printout will always appear a rhythm strip of raw data.

Ectopic beats are excluded from the process and shown in their original form as are tracings in which the original quality is extremely low.

To enable this function:

- In setup **Real Time** tab enable the **Clean Trace** check box.
- Select the 3x4 or 6x2 printout format.



Note

Dynamic ST and Clean Trace functions are available exclusively with the S2 Advanced Stress software.

Configured Summary Report

User formats narrative text and selects data fields to create report template. The system automatically merges text and data according to template selected.

To Print the Configured Summary Report

- Click **Print** button in main menu tab to open the final reports selector panel.
- Mark the **Configured Summary Report** check box.
- Click **Edit Summary** to preview the report.
- The report will be opened in the **Report Editor** window.
- If necessary select another template from **Templates** list.
- Edit the report text.
- Click **OK** button in the Report Editor top to save the changes.
- Finally, click **Print Reports** button to print the selected reports.

To Create or Modify a Template for Configured Summary Report

- Open Setup / **Printouts** tab.
- Click **Change** button near the **Configured Summary** parameter.
- Select the needed template in the list then click **Edit**.
- Edit the report template text in the Template Editor window.
- Use the **Insert Report Item** menu to enter values like patient name, DOB, protocol etc.
- Preview the the example report at the right side panel.
- Save the template changes and then close the Template Editor window.
- Select the needed template in the list then click **Set Active** to mark it as default.

RS232 Controlled Treadmill Types

Vendor	Model	Vendor's Fax	Email	RS232 Connector on the TM	RS232 Wiring Type
Norav /Trackmaster	TMX425	+1-316-283-3350		DB9 female	Straight
	TMX428	+1-316-283-3350		USB, DB9 female	Straight
GE /Marquette	2000 series			DB9 female (RS422)	M422*
				DIN 8 pin female	Tx -5 Rx - 4 GND - 2
Cardiac Science /QUINTON	TM-55		internationalservice@cardiacscience.com	DB9 female	Straight
	ST-55, ST-65			DB9 female (RS422)	Q422*
HP COSMOS / Schiller	All models	+49-8669-864249		DB9 female	Crossed
Lode	Valiant 110082			DB9, female	Crossed
	OEM2			USB	
Woodway	PPS55-MED			DB9 male	Crossed
Technogym	C-Safe protocol				
RAM	770	+39-049-8703388		DB9 female	Straight
SBI					
Powerjog	GM, J	+44-121-4333035			
System Biomedical		+91-22-4963147			
KIP Machines	KIP Series	+5411-4327-2963 +54341-464-7302 +54341-463-7919		DB9 Male	Lines: RX, TX, GND standard place in DB9 Male connector
BONTE MACHINEFABRIEK B.V.	Bonte	+ 31 038-4554030		DB9, crossed	Treadmill (SUB-D 25) <--- > PC (SUB-D 25) 2-----3 3-----2 7-----7
	Bonte2				
Parker	PM	+1-334-8213221		DB9 female	Straight
Parker	Parker 1200				
Micromed	Micromed				
Minato	AR-100			D-SUB 25P male	Straight, D-SUB 25 <--- > PC (D-SUB 25) 2-----2 3-----3 7-----7

* Requires a special adaptor, supplied by Norav Medical

Table 18: Controlled Treadmills

RS232 Controlled Bicycle Ergometers

Vendor	Model	Vendor's Fax	RS232 Connector on the Ergometer	RS232 Wiring Type	Note
LODE BV	Corrival		DB9 female	Straight	
LODE	EXCALIBUR				
Ergoline	ER900	+49-7431-989427	DIN 5 pin		
SECA	CT100	+49-40-20000050	DB9 male	Crossed	
ERGOSANA		+41-41-7618022	DB9 female	Straight	
Daum	ERGOFIT				
Tunturi	T-PROTOCOL				
Monark	Monark, Monark 839E		DB9 male	Crossed	
Technogym (bike)	C-Safe protocol				
Dimeq	770	+49-30-72376240			
ELMED					
Mitsubishi	StrengthErgo8		DB9 male	Crossed	
Konami	Aerobike 75XLIII		D-SUB 25 female	Crossed	"Basic" interface: no CheckSum, no ACK

Table 19: Controlled Ergometers

LATE POTENTIAL SIGNAL AVERAGING

(This option is available with the L1 license)

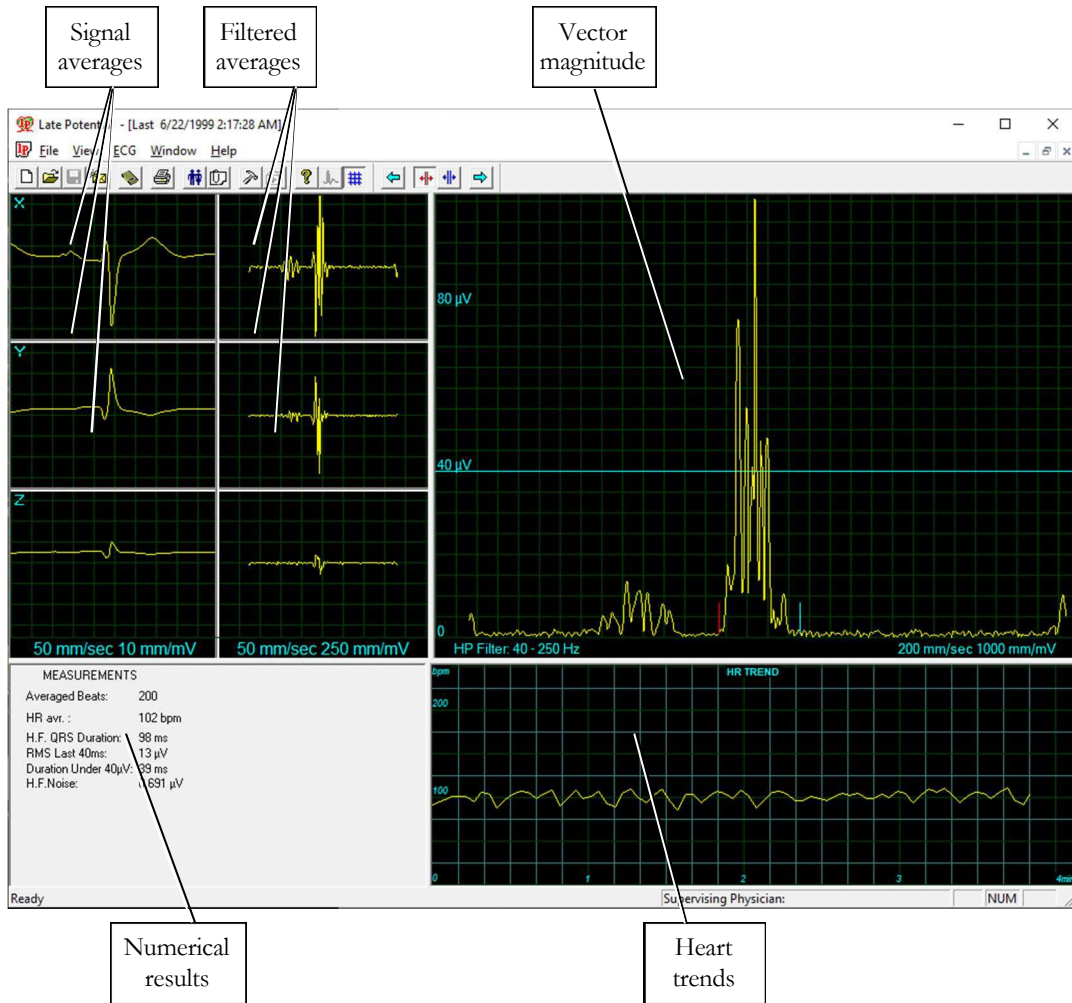

Figure 48: Late Potential Signal Averaging Screen

Quick Start

To Start a New Test

- Click **F1** (or the **New** button on the tool bar).
- Insert patient details in the dialog box.
- Click **OK**.
- Click **F3** or **F4** to start the LP averaging test.
- Enter the interval name and/or remarks as appropriate in the dialog box and click **OK**.
- Click **F3** or **F4** (or **Start/Stop Averaging** button) to stop the LP averaging test (or wait until it terminates).

To Print

- Click **F6**, or select **Print item** from the File menu.
- Select the printer from the Print dialog box.
- Click **OK** to close the dialog box and print the display (the LP averaging report or the ECG test).

Operation with Function Keys

F1	New recording
F3/F4	Start/stop
F6	Print
F11	Open saved study

Table 20: LP Signal Averaging Function Keys

For an example of a printed report, see Appendix C.

Leads

Recording is performed for leads X, Y, and Z (orthogonal) using the regular 12 lead cable. Arrange the leads as follows:

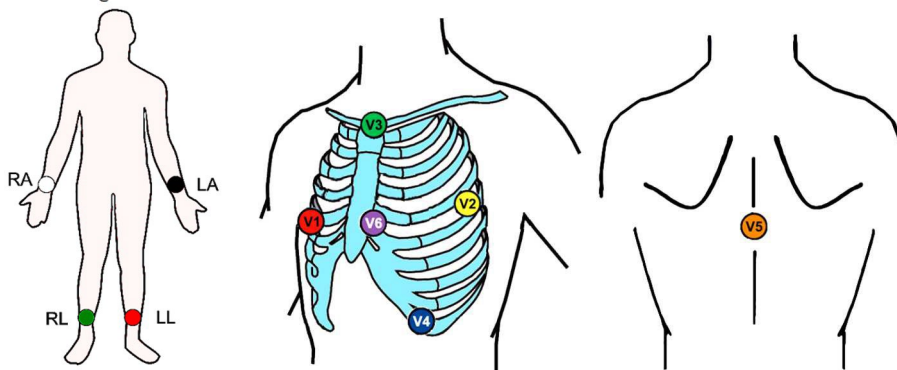

12 Lead	Orthogonal Lead (position)
V1	X- (right fourth intercostal space, mid axillary line)
V2	X+ (left fourth intercostal space, mid axillary line)
V3	Y- (superior aspect of the manubrium of sternum)
V4	Y+ (left iliac crest)
V5	Z- (directly posterior to positive Z)
V6	Z+ (fourth intercostal space just left of the sternum)
RA, LA, LL, RL	Same position as in 12 leads Resting ECG

Figure 49: LP Signal Averaging Leads Placement

LP Signal Averaging Setup











Click **Setup** on the Toolbar to access the following parameters:

Tab	Option	Description
ECG Recording	Auto Save(Save Options)	When Auto Save is ON, the file is stored by Last name or by ID. When Auto Save is OFF, the program requests a filename.
	Set File Name by (Save Options)	Set the naming convention for saving files (by Patient Last Name or ID)
	Simulator ECG	When cleared (default), ECG recording is performed from the PC-ECG unit. If checked, the ECG recording is performed from the demo file included in the software package. The recording unit is not required.
	Stop to confirm QRS	When ON, the user can choose the Normal QRS. When OFF, the program chooses the Normal QRS automatically.
	Template Correlation	Defines the QRS percentage match during signal averaging. A higher number corresponds to a better match.
	Target Number of Beats	Number of typical heartbeats that will be counted during the averaging stage.
	Use ECG Database	Check this option to connect to the default ECG database. ECG tests are saved in the database.
	Data Directory	Defines the directory for saved ECG recordings.
View	ECG's Colors	To modify the ECG colors, click the appropriate button and select the color from the color palette.
	Averages Color	To modify the colors in the Averages window, click the appropriate button and select the color from the color palette.
	HR Trend's Color	To modify the colors in the HR Trend's window, click the appropriate button and select the color from the color palette.
	Restore Defaults	Click to restore the default factory colors
Installation		Saves hospital and physician data. This data is included in print out and email.
	Measurement Standard	Define whether measurements will be calculated according to the metric or the USA standard. The default is metric.
	Magnetic Card Reader	Select this option to use a magnetic card with bar-code to insert patient details. Select the magnetic card type.
Environment	Connection	Use the option button (COM port/USB) to select the port for device connection. If COM port is selected, select the serial input for the PC-ECG unit from the COM port list. If the USB connection is selected, the COM PC-ECG selection list is disabled. (Default at installation is USB).
	Graph paper	If ON, prints 1mm and 5 mm squares on printouts. Regular grid prints from all printers. Improved grid shows a fine grid but may not work on some printers.

Tab	Option	Description
	Use Large Fonts for Remarks	Enlarges font for free typed text.
	Color printouts	Clear this option to force B/W printing on color printer.
	Display Size	This setting is required in order to display the ECG and grid in correct scale.
GDT/BDT Format	Automatic Options	Define automatic options for saving and/or importing files in GDT/BDT format.
	File Format	Select the file format: GDT or BDT
	Import Codepage 437	Check this option to import Code page 437.
	Export Codepage 437	Check this option to export Code page 437.
	Edit Labels	Click this button to open a dialog box with an editable list of the field labels used in the GDT and BDT files.
	GDT/BDT Data directory	Define the directory path where the GDT/BDT files will be maintained.
	Token for PCECG	Default is PEKG.
Token for Practice EDP	Default is EDV1.	
Holter File Path	Download Flash Card Program	Define the path for the flash card program directory.
	Download Directory	Define the directory to maintain the downloaded Holter files.

Table 21: LP Signal Averaging Setup

Toolbar and Menus

To do this	Click this icon	Or use this short-cut key	Or select this menu	Description
Start a new study		F1	File > New	Starts a new XYZ recording. The patient's demographic data can be entered prior to ECG recording (optional). The three channels are displayed on the screen for quality assurance. If the results are unsatisfactory, check skin preparation and disposable electrode contacts. Then click Start/Stop Averaging .
Open an existing study		F11	File > Open	Opens an existing study
Save a recording		Ctrl+S	File > Save	Saves recording to disk.
Send data via email			File > Send...	Sends recording data via email, if present on the computer.
Print results		F6	File > Print	Prints the active study
Import demographic data from HIS to PC-ECG			File > GDT/BDT Format For details see Import from GDT/BDT , page 125	This file always contains the last patient data.
Export the GDT/BDT file from PC-ECG to HIS			File > GDT/BDT Format For details see Save Test in GDT/BDT page 125	This file always contains the last patient data.
Set/change patient data			View > Patient Data	Adds this data to the recording. It is printed together with the ECG traces. If the recording is saved, then the PATIENT DATA is saved together with the ECG traces. Use the Previous option if the same patient undergoes a second study.
Add/view remarks			View > Remarks	Allows you type free text during or after the ECG recording. It is printed and saved together with the ECG traces.
Set preferences		Ctrl+T	View > Setup	Displays the setup dialog box and allows the user to tailor operation preferences.
To display information			Help > About...	Displays software version number (which should be quoted on any inquiry regarding the software). Also displays memory size and disk free space.
Start/Stop Averaging		F3/F4	ECG > Start/Stop Averaging	Allows the user to start the averaging period. The averaging period default is 200 beats. It can be changed in OPTIONS, ECG RECORDING, and TARGET NUMBER







To do this	Click this icon	Or use this short-cut key	Or select this menu	Description
Display/Hide the grid			View > Grid	Optional display of 5 mm raster. Print outs are always with 1 mm raster.
Start monitoring.		F2	ECG > Start/Stop Monitoring	Starts monitoring.
Stop monitoring		F2	ECG > Start/Stop Monitoring	Stops monitoring.
Activate Onset Marker		Ctrl+←	ECG Onset marker	Allows the user to move the Onset Marker using the direction arrow icons.
Activate Offset Marker		Ctrl+→	ECG Offset marker	Allows the user to move the Offset Marker using the direction arrow icons.
Move the On and Off markers				Allows the user to move the ON/OFF markers.

Table 22: LP Signal Averaging Toolbar and Menus

Interpreting Results

When the signal-averaging phase is complete, the result screen is displayed:

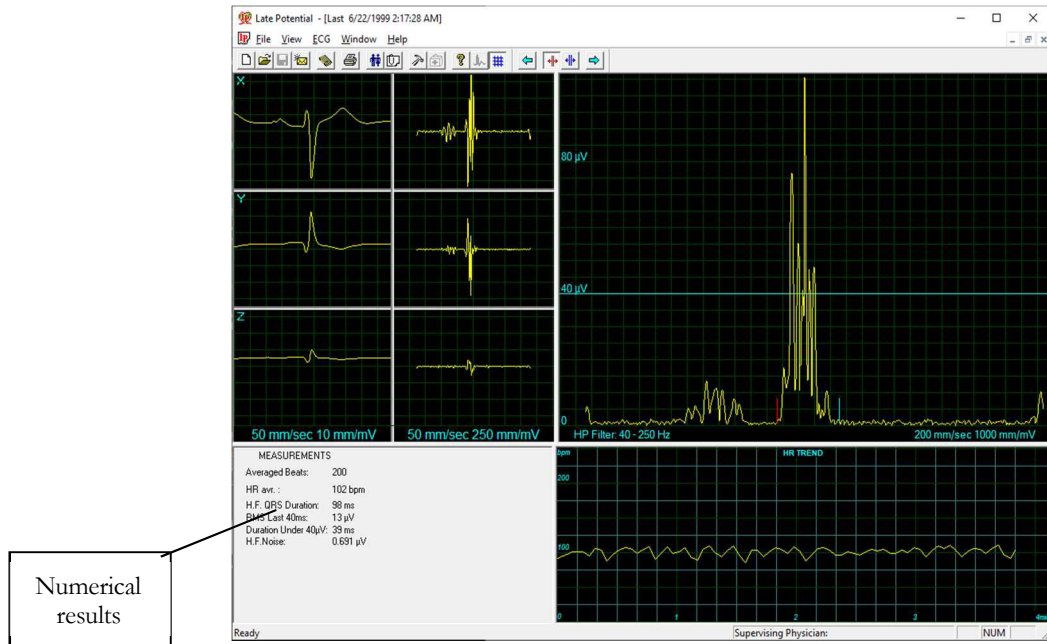

Figure 50: LP Signal Averaging Review Screen

Numerical Results

The results are calculated automatically. You can overrule the automatic positioning of the ONSET/OFFSET markers with the direction keys.

Averaged Beats	Displays the number of averaged normal beats captured during the study.
HR Average in beat/min	
High Frequency QRS Duration in Milliseconds from Onset to Offset	Displays the width of the filtered QRS containing only high frequencies. A higher number indicates higher patient risk.
RMS LASTS 40 milli-seconds in Microvolts	Displays the total activity for the last (40ms) portion of the QRS. A lower number indicates higher patient risk.
DURATION UNDER 40 Microvolts in Milliseconds	Shows the period in ms from offset of the QRS till the first point of 40uV activity. A higher number indicates higher patient risk.
H.F. Noise: in Microvolts	Quality assurance. A lower number corresponds to higher result accuracy. The maximum number should not exceed 1 µV.

Table 23: LP Signal Averaging Numerical Results

MONITORING ECG

(This option is available with the M1 license)

This option enables long-term recording and storage to disk. The user decides which leads and at which sample rate to monitor on screen and save to disk. During the study, you can print in real time on a thermal printer.

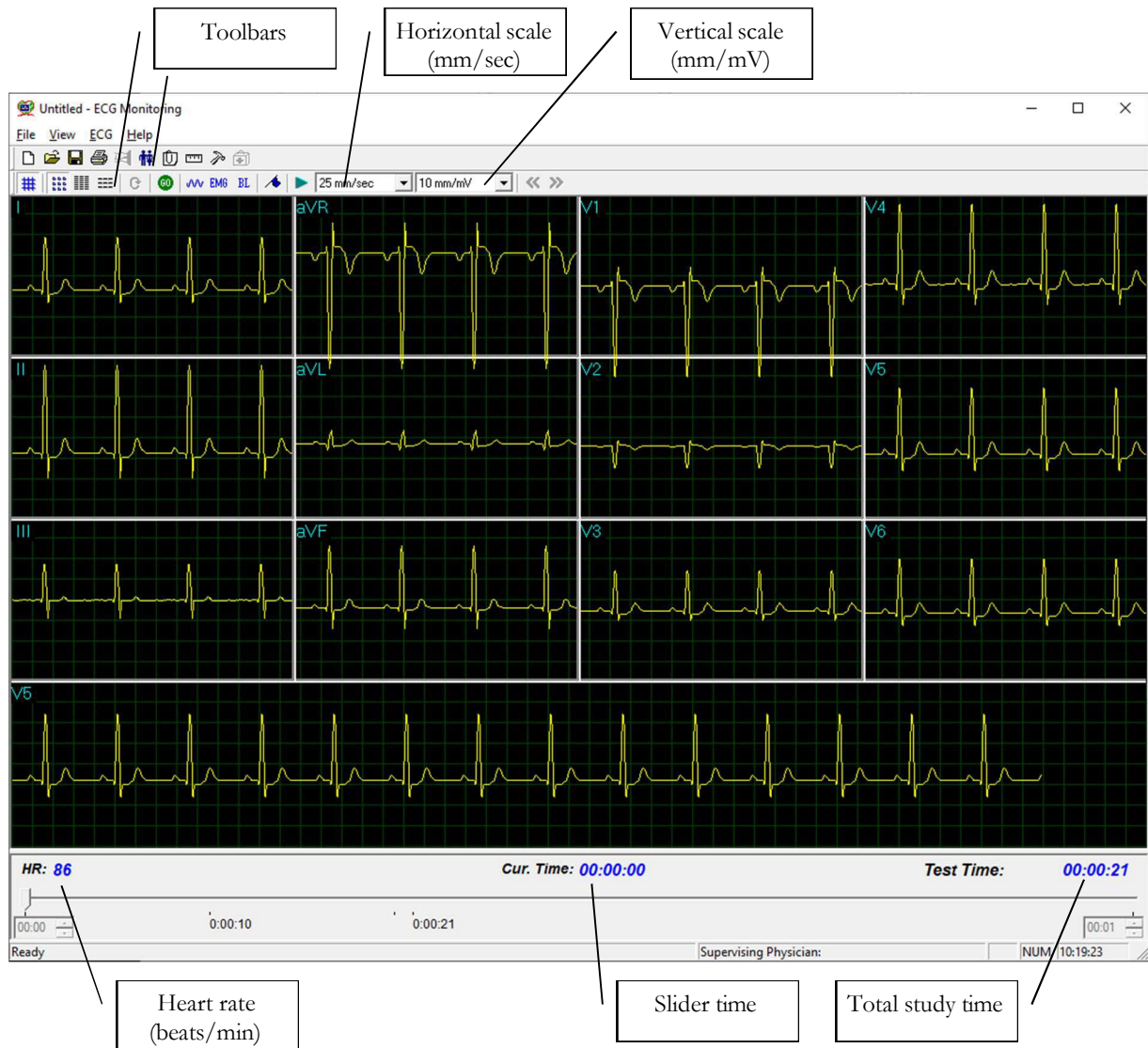

Figure 51: Monitoring ECG Screen

Quick Start

To Start a New Test

- Click **F1** (or the **New** button on the tool bar).
- Insert patient details in the dialog box.
- Click **OK**.
- Click **F2** (or **Start/Stop** button) to stop data collection or wait until end time.

To Print

- Click **F6**, or select **Print item** from the File menu.
- Select the printer from the Print dialog box.
- Click **OK** to close the dialog box and print the display.

Print Study (print a selected time range and leads)

- Click **Print Study** on the toolbar or select **Print Study Item** from the **File** menu.
- Define the time range and select the leads to print from the dialog box.
- Click **OK** to acknowledge selection and close the dialog box.
- Select the printer in the Print dialog box.
- Click **OK** to start printing.

Monitoring ECG Setup













Click **Setup** on the Toolbar to access the following parameters:

Tab	Option	Description
Sample Rate\Leads Selection	Leads	Allows the user to select leads. To select all leads, click Select All . To deselect all leads click Unselect .
	Sample rate	Allows the user to choose requested samples per second per channel.
	X,Y,Z	Check this option to monitor X, Y, and Z axis. Clear the option to select the other leads to be displayed and monitored on screen. With this option, monitoring other leads is not possible (default is cleared).
12 Leads View	Default 3 leads	This function is available only if 12 lead monitoring is selected. 3 leads appear if 3x1 format is used.
	Strip Lead	10 sec. lead appears in 4x3 and 6x2 formats.
ECG recording	Filter 50/60Hz	When checked, the default status of 50/60Hz filter is ON (according to the checked frequency 50 or 60). Default is cleared.
	EMG Filter	When checked, the default status of the EMG filter is ON. Default is cleared.
	Baseline filter	When checked, the default status of the Baseline filter is ON. Default is cleared.
	Save options	If Auto Save is ON the file is stored by last name or by ID. If Auto Save is OFF the program requests a filename.
	Simulator ECG	If cleared (default), ECG recording is performed from PC-ECG unit. If checked, ECG recording is performed from the demo file included in the software package. The recording unit is not needed.
	ECG Recording time (h:m)	Determines study duration in minutes.
	Data Directory	Defines the directory for saved ECG recordings. Use secondary hard disk if available.
View	Draw Over Lead Borders	If checked (default), does not limit the extreme high amplitude ECG pulses from exceeding the borders. If cleared, chops the pulses at the borders.
	Horizontal Scale	Sets the default value for the Horizontal scale window on the screen.
	Vertical Scale	Sets the default value for the Vertical scale window on the screen.
	Slider step size	Off line function. Sets the default value for slider steps when moved by mouse or arrow keys.
	Colors	Allows the user to choose colors.
	Restore Defaults	Restores factory defaults.
Installation		Saves hospital and physician data. This data is included in print out mail.
	Measurement Standard	Define whether measurements will be calculated according to the metric or the USA standard. The default is metric.

Tab	Option	Description
	Magnetic Card Reader	Select this option to use a magnetic card with bar-code to insert patient details. Select the magnetic card type.
Environment	Connection	Select the option button (COM port/USB) to choose the port for device connection. If the COM port option is selected, select the serial input for the PC-ECG unit from the COM port list. Disabled if the USB connection is selected. (Default at installation – USB)
	Display Size	This setting is required to display the ECG and grid in correct scale.
	Graph paper	If set to On, it prints 1mm and 5 mm squares on printouts. Regular Grid is guaranteed to fit any printer. Improved Grid shows a fine grid but may not work on some printers.
	Large Remarks font	Enlarges printed text.
	Color Printout	Forces B/W printing on color printer.
	Thermal Plotter	Sets LPT port for optional thermal paper.
GDT/BDT Format	Automatic options	Setup automatic options for saving and/or importing files in GDT/BDT format.
	File Format	Select the file format: GDT or BDT
	Import Codepage 437	Check this option to import Code page 437.
	Export Codepage 437	Check this option to export Code page 437.
	Edit Labels	Click this button to open a dialog box with an editable list of the field labels used in the GDT and BDT files.
	GDT/BDT Data directory	Define the directory path where the GDT/BDT files will be maintained.
	Token for PCECG	Default is PEKG .
	Token for Practice EDP	Default is EDV1 .

Table 24: Monitoring ECG Setup Options

Toolbar and Menus

To do this	Click this icon	Or use this short-cut key	Or select this menu	Description
Start a new study		F1	File > New Test	Starts a new monitoring session. Patient data can be entered prior to ECG recording (optional). The recording time is set in SETUP for ECG RECORDING. The user can stop recording by clicking the GO/STOP icon.
Open an existing study		F11	File > Open	Shows recordings saved on disk.
Save a recording		Ctrl+S	File > Save	Saves recording to disk.
Print results		F6	File > Print	Off line printing. Determine the time range to be printed. The acquired ECG is printed in miniature format horizontal: 6.25 mm/sec and vertical: is the 2.5 mm/mV.
Export to Rest			File > Export to Rest	A 10 sec segment containing original leads I, II, V1...V6 and calculated leads III, aVR, aVL, aVF is transferred into Rest format (up to 12 leads 10 sec). Calculated leads are performed only if I and II are acquired.
Export to MATLAB			File > Export to MATLAB	A 10 sec segment containing acquired leads is transferred into MATLAB format.
Import from ISHNE			File > Import from ISHNE	Long-term high resolution ECG recorded on Holter can be transferred into a monitoring study
Plot in real time				Real time printing on a thermal printer. Can print continuously while monitoring up to 8 leads.
Set/change patient data			View > Patient data	Displays patient demographic information.
Add/view remarks			View > Remarks	Allows the user to enter free text during or after the ECG recording. This is printed and saved together with ECG traces.
Set preferences				Allows the user to tailor operation preferences.
To display information			Help > About...	Software version number. Quote this for any software inquiry. Also shows memory size and free disk space. The HASP ID number is the ID of existing software keys. This ID number is used for adding software options.
Display/Hide the grid			View > Grid	Optional display of 5mm raster.
Start ECG Recording.		F2	ECG > Start/Stop	Starts ECG recording.
Stop ECG Recording		F2	ECG > Start/Stop	Stops ECG recording.
Display 3x4 Leads		Ctrl+1	View > Leads format > Windows	Classical format. Displays 12 lead ECG of 2.5 sec ECG + 10 sec trace.*







To do this	Click this icon	Or use this short-cut key	Or select this menu	Description
Display 12x1 Leads		Ctrl+2	View > Leads format > All leads	Displays 12 lead ECG of 10 sec ECG.*
Display 3x1 Leads		Ctrl+3	View > Leads format > Lead group	Displays 3 lead ECG of 10 sec ECG.*
Display the next leads		Ctrl+0	View > Leads format > Next leads	Allows the user to scroll through all leads in the 3x1 format display
Set 50/60 Hz filter			ECG > Filters > 50/60 Hz	ON/OFF for line interference filter. Set OPTIONS for 50 or 60 Hz prior to operation
Set EMG filter			ECG > Filters > EMG	ON/OFF for muscle noise filter
Set base line filter			ECG > Filters > BaseLine	ON/OFF for baseline filter on ECG data

Table 25: Monitoring ECG Toolbar and Menus

- * ECG data can be set up as limited amplitude or unlimited amplitude, which can cause one lead data to overlap a neighbouring lead.

HEART RATE VARIABILITY (HRV)

(This option is available with the H1 license)

Time and frequency domain analysis is designed for short studies in which one or more time segments are measured, as in a Tilt study.

Measured/reported parameters are according to NASPE/ESC Guidelines.

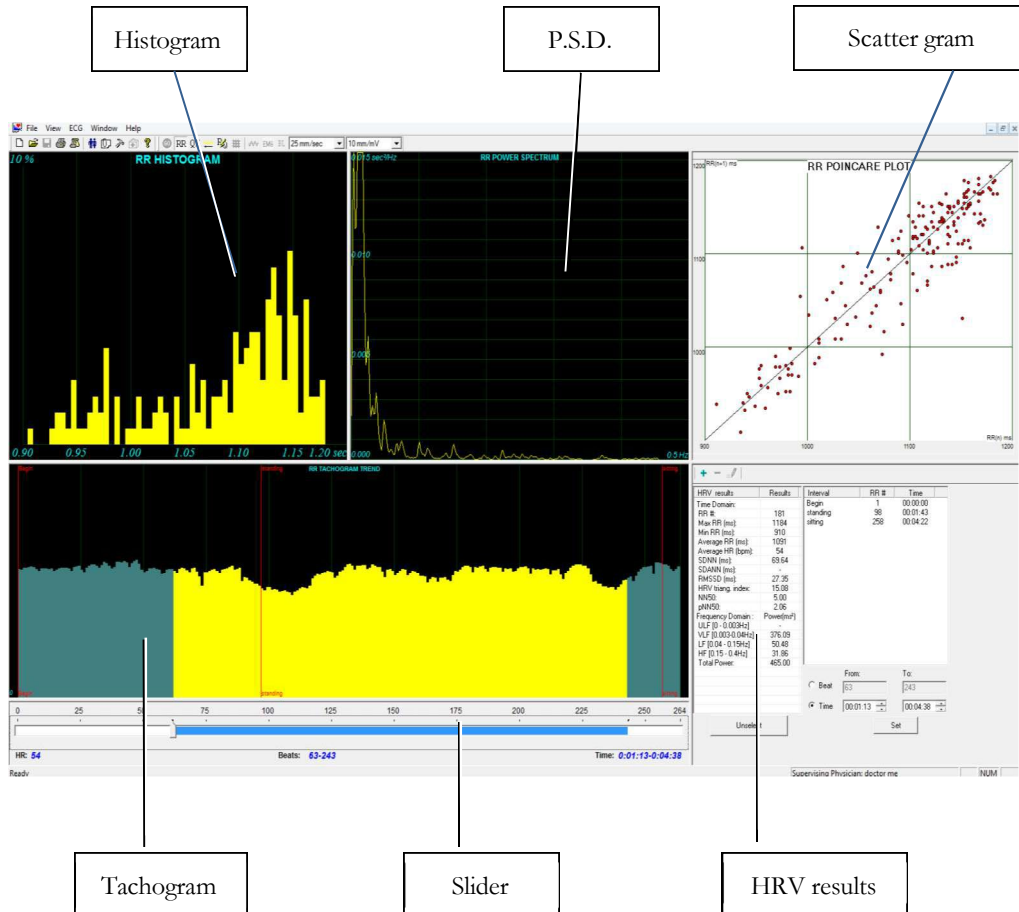

Figure 52: Heart Rate Variability Screen

Key:	
Histogram	The histogram relates to the active part (yellow) of the tachogram
P.S.D.	The power spectrum distribution
Tachogram	The tachogram trend shows all intervals. Each beginning of an interval is checked with a red line followed by the interval's name. To activate an interval, click it. To activate several neighbouring segments, press SHIFT and move the slider.
Scattergram	Poincare plot of the current R-R interval plotted against the preceding R-R interval.
Slider	Use the slider at the bottom to: Define new intervals Change interval duration, and Activate several intervals
HRV results	The HRV results pane displays the results in numerical format.

Table 26: HRV Screen

Quick Start

To Start a New Test

- Click **F1** (or the **New** button on the tool bar).
- Insert patient details in the dialog box.
- Click **OK**.
- Click **F3** or **F4** to start the HRV test.
- Enter interval name and/or remarks as appropriate in the dialog box and click **OK**.
- Click **F3** or **F4** (or **Start/Stop HRV** button) to stop HRV test (or wait until it ends).

To Print an HRV Report

- Click **Print** on the toolbar or select **Print** from the file menu.
- Select the printer from the print dialog box.
- Click **OK** and the report is printed.

For an example of a printed report, see **Appendix C**.

To Print an ECG

- Click the **Print ECG** button on the toolbar or select **Print ECG** from the file menu.
- Select the beats and leads to print from the dialog box and click **OK**.
- Select the printer from the print dialog box.
- Click **OK** to close the dialog and print the ECG.

HRV Setup

Tab	Option	Description
Sample Rate\Leads Selection	Leads	Choose leads and sampling rate. Select up to four neighbouring leads for calculations.
ECG Recording	Filters	Set filters as active.
	Test Duration	Define the test duration either by target number of beats or by the ECG recording time. Select the preferred parameter and define the value for the test duration.
	Auto Interval	Sets the interval times which will be created automatically. When this option is checked the ECG test will be split into equal time intervals during the ECG recording. Adjust the Duration parameter to set the length of the interval times.
	Save Options	To save test automatically at the end of the test, check the Auto Save option. When this option is cleared, the test is saved only on demand. Define the saving format either as No ECG Data or Full Disclosure . Define the file naming convention of the saved files, either by Patient Last Name or ID.
	Use ECG Database	Select this option to connect to the default ECG database. When this option is checked, the ECG tests are saved in the database.
ECG Recording	Data Directory	Define a directory for saved ECG recordings (if ECG database is not used). Use a secondary hard disk, if one is available.
	Simulator ECG	When cleared (default), ECG recording is performed from the PC-ECG unit. When checked, the ECG recording is performed from the demo file included in the software package. In this case, the recording unit is not needed.
View		Change default colors for ECG and for graphs.
	Restore Defaults	Restores factory default color definitions for ECG display and graphs.
Installation		Saves hospital and physician data. This data is included in print out and mail.
	Measurement Standard	Define whether measurements will be calculated according to the metric or USA standard. The default is metric.
	Magnetic Card Reader	Select this option to use a magnetic card with bar-code to insert patient details. Select the magnetic card type.
Environment	Connection	Select the option button (COM port/USB) to choose the port for device connection. If the COM port option is selected, select the serial input for the PC-ECG unit from the COM port list. The option is disabled if the USB connection is selected. Default at installation is USB .
	Display Size	This setting is required to display the ECG and grid in correct scale.
	Graph Paper (Print options)	When set to On, prints 1mm and 5 mm squares on printouts. Regular Grid works with any printer. Improved Grid shows a fine grid but may not work on some printers.
	Large Remarks Font	Enlarges font for free typed text.
	Color Printout	Clear the check-box to force B/W printing on color printer.
GDT/BDT Format	Automatic Options	Define automatic options for saving and/or importing files in GDT/BDT format.
	File Format	Select the file format: GDT or BDT
	Import Codepage 437	Check this option to import Code page 437.
	Export Codepage 437	Check this option to export Code page 437.
	Edit Labels	Click to open a dialog box with an editable list of the field labels used in the GDT and BDT files.
	GDT/BDT Data directory	Define the directory path where GDT/BDT files will be maintained.
	Token for PCECG	Default is PEKG .
	Token for Practice EDP	Default is EDV1 .

Table 27: HRV Setup

Starting a Study

- Click **New**.
- Enter patient data in the Patient Data field.

- The ECG leads are monitored on the screen for quality check.
- If you are satisfied with the quality check, click the **R-R** icon. The display comprises three sections:
 - ◇ The ECG leads are displayed on the upper part of the screen
 - ◇ The tachogram trend display is built up in the middle strip.
 - ◇ A slider shows the study status and time at the bottom
- During the study, define a new time segment (interval) by clicking the flag icon (interval). Name each interval during the study to retain it as a valid interval.
- When all predefined beats are completed, or if terminated by clicking the **R-R** icon, the HRV screen is displayed.

To Add or Subtract an Interval

- Select the interval with the slider or using the FROM-TO controls at the right side panel.
- Click **+** or **-** at the top of the HRV results pane.

To Edit Interval Names

Use the pencil icon.

To split the whole test into equally timed intervals

- **Online:** Activate the **Auto Interval** check box in **ECG Recording** setup tab. Selecting this option will create equal length time intervals during the ECG recording.
- **Offline:** Select the **Define Time Intervals** command under the **View** main menu tab. This option will create equal length time intervals on a stored recording.

To Import or Save GDT/BDT Format

See **Import from GDT/BDT** and **Save Test in GDT/BDT**.

Results Display

The AVERAGE HEART RATE is displayed in the lower left side.

All results are for the chosen segment (check the yellow selection or the From-To bits number).

Other results are shown in the right hand side as follows:

Time Domain	RR no.	Number of beats in the active interval
	max RR	Longest R-R period
	min RR	Shorter R-R period
	Average RR	Average of interval in active interval
	SDNN	Standard deviation of all R-R periods in interval
	SDANN	Standard deviation of the averages of R-R periods in all 5 min segments of the active interval
	RMSSD	The square root of the mean of the sum of the squares of differences between adjacent NN intervals
Frequency Domain	HRV triangular Index	Total number of all R-R intervals divided by the height of the histogram of all R-R intervals measured on a discrete scale
	ULF	Power of the ultralow frequency range
	VLF	Power of the very low frequency range
	LF	Power of the low frequency range
	HF	Power of the high frequency range

Table 28: HRV Results

HRV Interval Measurement

A QRS detector measures the interval between any two valid beats. It calculates a sliding N-N average and compares each interval to it. When a significant change occurs, the current beat is either a premature beat (as in PVC) or a prolonged one, which may indicate either a compensatory pause following a PVC or a missing beat. A premature interval and a following prolonged interval (compensatory pause) timed in the range of twice the current N-N interval are averaged. This methodology maintains a consistent time axis in the presence of PVCs. If a prolonged interval follows a normal interval, but at twice the current N-N interval, it indicates the presence of a missing beat. Accordingly, the missing beat is computed as present. This last event is very rare, because the recording is made in rest condition and the software detects the QRS efficiently under such conditions.

MEASUREMENTS/ INTERPRETATION (MEANS)

(This option is available with the I1, I2 or I3 license)

Measurements is not an autonomous application. The **Measurements** application is used for calculations of QRSs and interpretation of the ECG signal. The user can manually change the QRS identification parameters. 10 seconds of data are calculated.

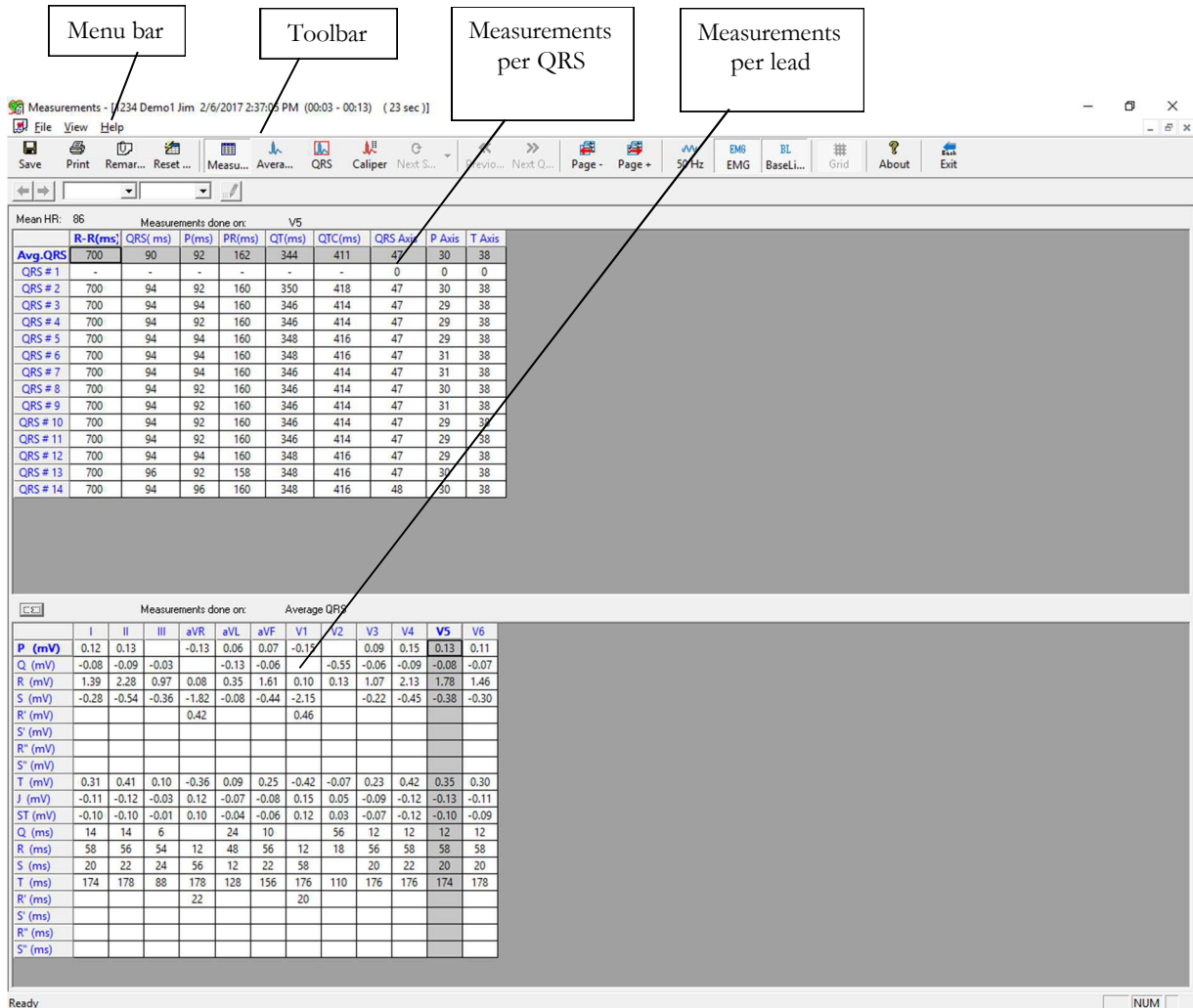

Figure 53: Measurements—Tabular Screen

Quick Start

To Start Measurements

Click the measurements area in the **Resting ECG**, or ruler icon in **Stress ECG** and **Monitoring ECG** applications, or click **View > Measurements**

The application has four view formats:

- Measurements Table (default display)
- ECG Averages
- QRS Signal
- Caliper

To Print Reports

- Click the printer icon or select **File > Print Reports**.
- Select the reports to print and click **OK**.

Performing Changes in Calculations

To Move the QRS Marker

(Averages and QRS views only)

- Click and drag the marker to the required position (between the previous and next markers).
- The calculations are modified accordingly.

To Add or Remove a Wave Marker

- Click the **Add/Remove ECG Wave Markers** icon on the toolbar
- Check or clear wave markers in the dialog box displayed.
- Click **OK** to save the selection, close the dialog box, and display the change.

To Move the Wave Marker

(Caliper view only)

- Select a wave from the wave list on the left hand side of the viewer (or from the **Wave Type** combo box).
- Select the marker from the **Marker Name** combo box in the toolbar or by clicking the marker.
- Use the Left/Top/Right/Bottom arrows on the toolbar or drag & drop the marker to the required position.
The calculations are modified accordingly.

Features

View all calculated parameters on every QRS, on every channel and average calculations in tabular format.

The upper table displays measurements for a channel.

The lower table displays measurements values for a QRS.

To View the Measurements on a QRS

Select a QRS from the upper table and view the results on the lower table.

To View the Measurements on a Channel

Select a channel from the lower table and view the values on the upper table.

To View the Measurements on All Channels for QT

Click “>” (between the two tables) to view measurements for **All Leads for QT** on the lower table.

Tabular Screen

The Tabular screen displays calculations of the QRS parameters in all the leads in a tabular format. Original calculations or changes performed in the other screens (Averages, QRS, or Caliper) are displayed in a tabular format and can be printed out.

Averages Display

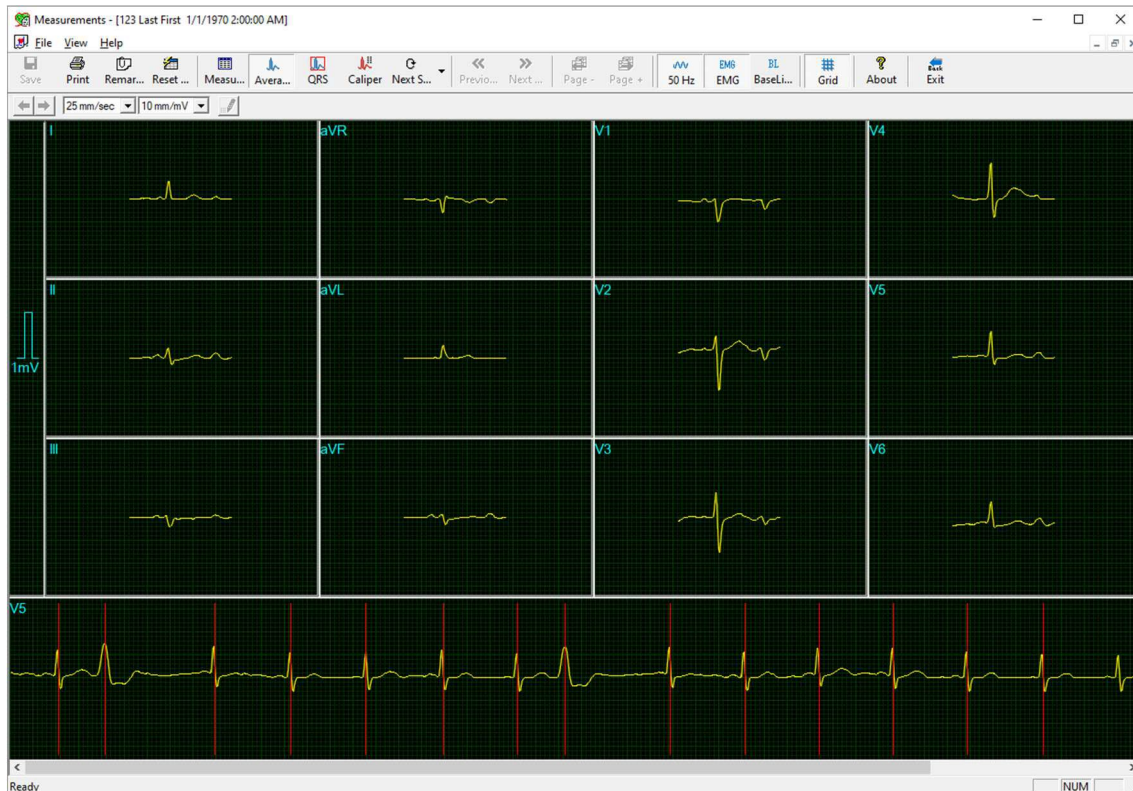

Figure 54: Measurements—Averages Display

The Averages screen displays the average QRS in each of the leads and the average ECG of the Strip lead. Each QRS identified is marked with a red marker in the strip lead (The marker actually marks the R wave of every QRS). The QRS markers can be moved to the left and right (between the previous and the next marker). Changes in marker positions are recalculated and displayed in the tabular screen and the QRS screen.

QRS Display

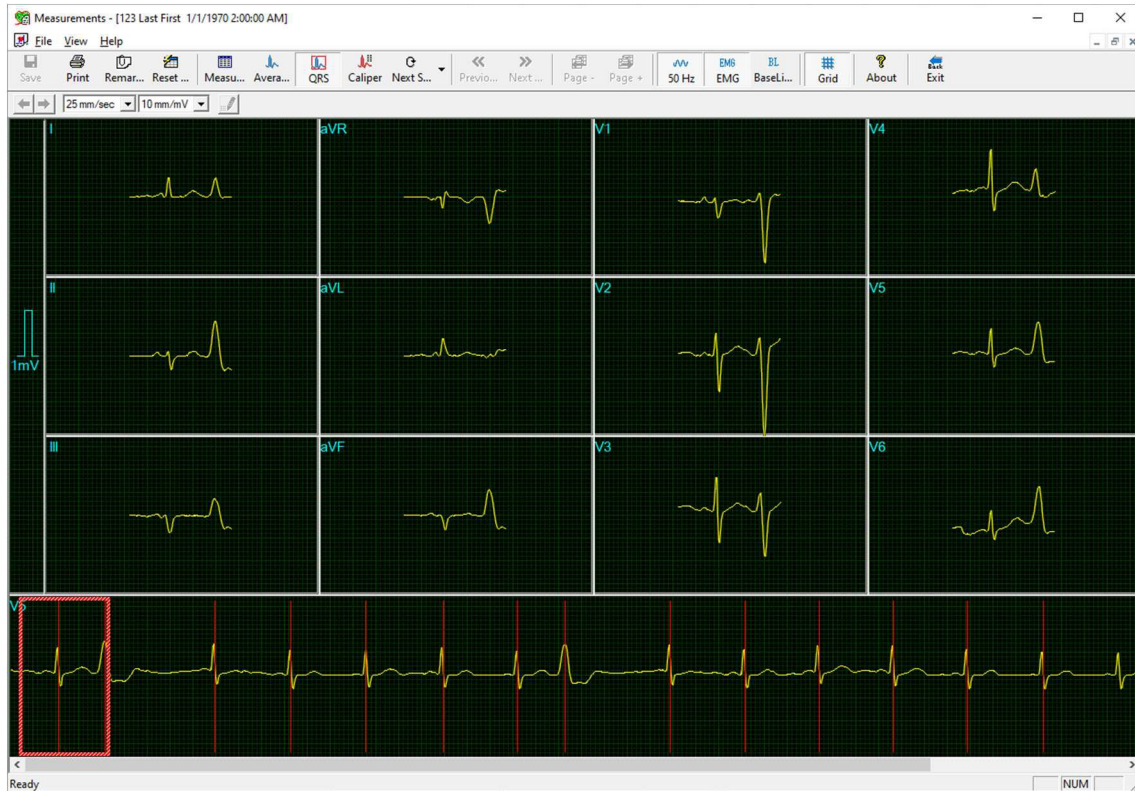

Figure 55: Measurements—QRS display

The QRS screen displays the QRS in each of the leads and a strip lead of a default lead (defined in the setup of the application from which Measurements was accessed). The QRS displayed in each of the leads is marked by a red rectangle in the strip lead. To view a different QRS in all the leads, drag and drop the square by to a different QRS. The QRS markers can be moved to the left and right (between the previous and the next marker). Changes in marker positions are recalculated and displayed in the tabular screen and the Averages screen.

Toolbar of Averages/QRS Displays

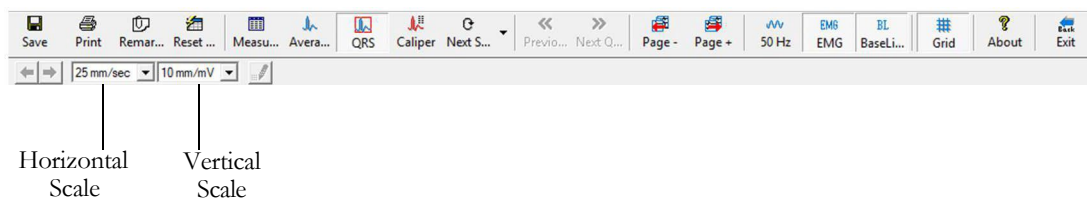

Figure 56: Toolbar of Averages/QRS

Caliper Display

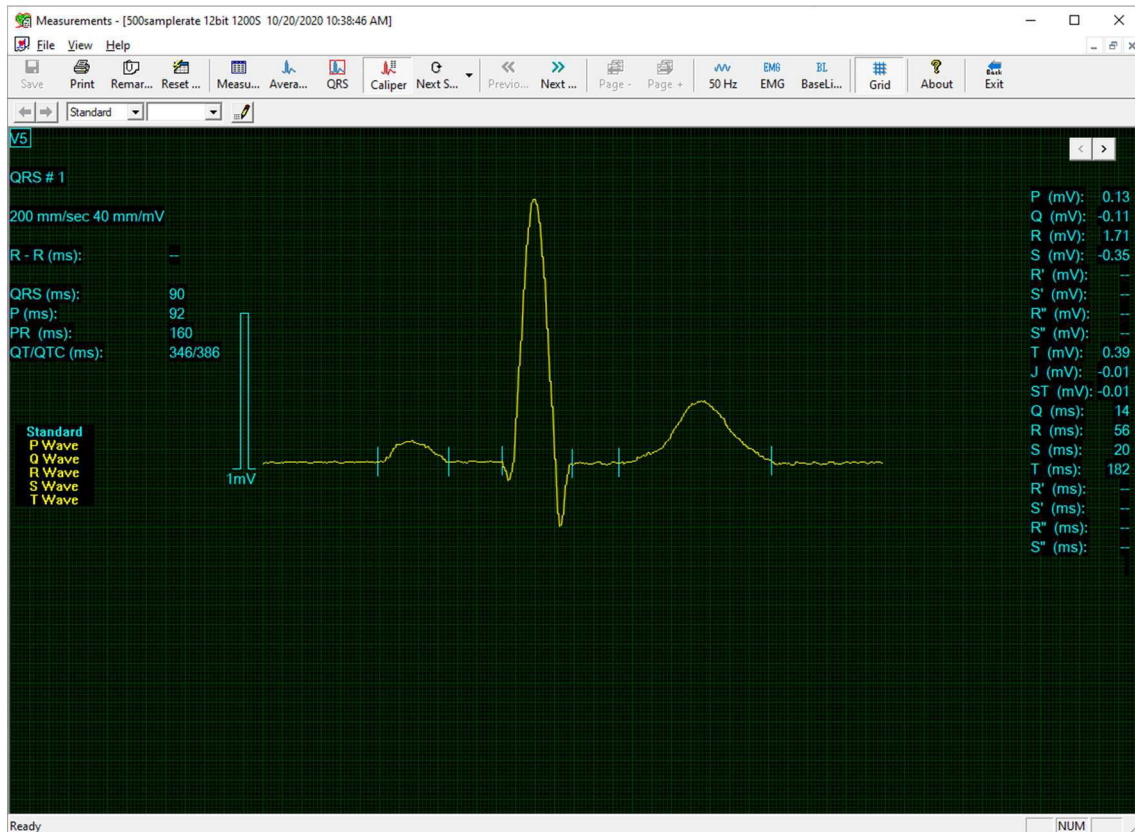

Figure 57: Measurements—Caliper

Toolbar of Caliper Display

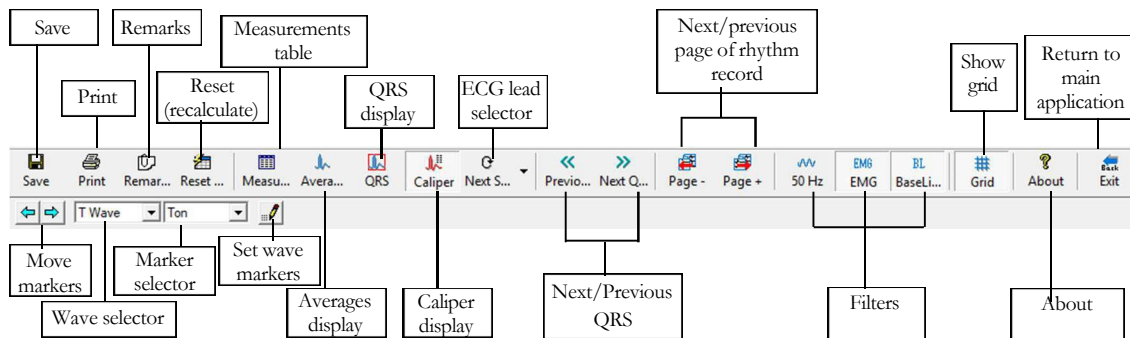















Figure 58: Toolbar of Caliper

The Caliper screen (above) is opened via the menu, the toolbar, or by double clicking a lead in the QRS or Averages screens. It displays one QRS with its values. The user can edit locations of wave markers, display different QRS in the same lead, or navigate through leads and display QRS in different leads. Changes in wave marker positions are recalculated and displayed in the tabular screen.

Toolbar and Menus

To do this	Click this icon	Or use this shortcut	Or select this menu	Description
Save Measurements		Ctrl+S	File > Save	Saves measurements to test file on disk.
Print ECG		F6	File > Print ECG	Off line printing. The ECG is printed in miniature format. Horizontal: 6.25 mm/sec, vertical: 2.5 mm/mV.
Add/View Remarks		Alt+V+R	View > Remarks	To enter free text during or after the ECG recording. This is printed and saved together with ECG traces.
Reset Measurements		Alt+F+M	File > Reset Measurements	Reset measurements to those calculated by the application. This option will eliminate all the modification performed manually in the measurements.
To Open Measurements in Table Format			View > View Format > Measurements table	Displays the measurements in a table format.
To Display QRS Averages			View > View Format > Averages	Displays the QRS averages on screen.
To Display QRSs in All the Channels			View > View Format > QRS	Displays the QRSs in all the channels on screen .
Display Caliper			View > View Format > Caliper	Displays the Caliper.
Display the Next Leads		Ctrl+0	View > View Format > Next strip	To scroll through all leads in the 3x1 display.
Display/Hide the Grid			View > Grid	Optional display of 5 mm raster.
To Display Information			Help > About...	Displays software version number. Quote this for any software inquiry. Also shows memory size and free disk space. The HASP ID number is the ID of existing software keys. This ID number is used for adding software options.
Previous QRS Next QRS			View > View Format > Previous QRS/ Next QRS	Moves to previous QRS or next QRS on the same channel.
Page - Page +			View > View Format > Previous 10 sec ECG / Next 10 sec ECG	Moves to previous / next 10 sec ECG page of rhythm recording.
Set 50/60 Hz Filter			ECG > Filters > 50/60 Hz	ON/OFF for line interference filter. Set OPTIONS for 50 or 60 Hz prior to operation.









To do this	Click this icon	Or use this shortcut	Or select this menu	Description
Set EMG Filter			ECG > Filters > EMG	ON/OFF for muscle noise filter.
Set Base Line Filter			ECG > Filters > BaseLine	ON/OFF for baseline filter on ECG data.
Move Marker to Right/Bottom			-----	Enabled in Caliper screen when a wave type and marker name are selected. Click to move the marker right or down (according to the marker selected). Disabled when no wave marker is selected or the Caliper screen is not displayed.
Horizontal Resolution			-----	(Averages and QRS screens) To choose between horizontal displays of 12.5, 25, 50, and 100 mm/sec. (Default: 25 mm/sec)
Select QRS Wave Type			-----	In Caliper, lets you select the QRS wave type from the list to view its markers. After selecting the wave type, select a marker name to move it.
Vertical Resolution			-----	(Averages and QRS screens) To choose between vertical displays of 5, 10, 20, and 40 mm/mV. (Default: 10 mm/mV)
Select Name of QRS Marker			-----	In Caliper, lets you select the name of a marker to edit it (move it up/down/left/right).
Add/Remove ECG Wave Marker			File > Add/Remove ECG Wave Marker	(Caliper screen only) Opens a dialog box and lets you check/clear the wave markers to be displayed and calculated.
Print Reports	-----		File > Print Reports	To choose the report to be printed from the sub-menu: Single QRS/QT Report, Multiple QRS Report, or All Reports.

Table 29: Measurements Toolbar and Menus

NEMS APPLICATION

(This option is available with the D1\D2\D3 license)

Norav ECG Management System (NEMS) application is an optional package requiring a NEMS-A or NEMS-Q permission license. Install NEMS database and application from dedicated installation package CD/DVD.

For information regarding the NEMS application, please consult the NEMS operating manual.

INTERFACING WITH INFORMATION SYSTEMS

There are several ways to exchange information between PC-ECG 1200 and Hospital Information System (HIS). These are described below:

Demographic Data

Information System Prepares Patient Demographic Data for PC-ECG 1200:

This uses a text file called PatientFile.ini. The location is defined in NEMS setup.

File Name: PatientFile.ini

File Format:

[PATIENTDATAXXX]

ID=

LastName=

FirstName=

BirthDay=

BirthMonth=

BirthYear=

Sex=

Weight=

Height=

Address=

Phone1=

Phone2=

Fax=

E-Mail=

Medications=

Other=

[PatientDataXXX]—Section name. XXX—number from 000 to 200.

At least one of the keys **ID**, **LastName**, or **FirstName** must be completed. If all these keys are empty, section of this patient will be ignored.

The keys **Height**, **Address**, **Phone1**, **Phone2**, **Fax**, **Email**, **Medications** and **Other** appear only with Database.

Example:

[PatientData001]

ID=1234567890

LastName=Smith

FirstName=Worker

BirthDay=11

BirthMonth=6

BirthYear=1959

Sex=1

Weight=59

Height=170

Address=523 Main st. Tacoma Mexico

Phone1=702-8765643

Phone2=702-8743031

Fax=702-8743032

E-Mail=nkir@sympo.ca

Medications=none

Other=none

[PatientData003]

ID=123456789

LastName=Smith

FirstName=Worker3

HL7 Format File

PC-ECG Prepares HL7 Format File with Stress Test Results

This file is created upon demand in the study review screen.

The file of Stress test in Format HL7 includes:

- **Patient Information:**

Name:	John
Last Name:	Smith
Id Number:	12345678
Birth Date:	24/1/1955
Sex:	M
Weight:	80 kg

- **Hospital and Physician Information:**

Hospital Name:	General Hospital
Hospital Address:	Megapolis
Physician Name:	Dr. Stern

- **Test Date and Time:**

Test Date:	18/09/1999
Test Time:	12:41:51

- **Test Results:**

Protocol:	Bruce
Target HR:	183
Max HR:	175 (95%)
Max. SBP:	200
Max. DBP:	100
Max. METS:	8.8
Max. VO2:	30.9
ST =	J+60

- **Results of Blood Pressure, HR, Double Product (HRxBP sys.), ST level (mm) and ST Slope (mV/sec) for the Most Important Stages of Stress Test:**

Rest: BP: 150/100, HR: 79, Product: 11850, ST Level (mm), Slope (mV/sec) (-1.2/0.7, 0.2/1.8, 1.9/-0.5, -2.0/0.4, -2.9/3.3, -1.1/2.6, -1.4/2.2, -1.6/1.8, -1.3/6.1, -1.8/2.5, -1.7/1.5)

Max HR: Time: 7:05, BP: 200/100, HR: 175, Product: 35000, ST Level (mm), Slope (mV/sec) (-1.2/0.7, 0.2/1.5, 1.9/-0.5, -2.0/0.1, -2.9/3.3, -2.1/2.6, -1.4/2.2, -1.4/1.8, -1.7/6.1, -1.2/2.4, -1.7/1.5)

Worst ST: Lead aVF: -1.2 mm, Time: 4:15, BP: 200/100, HR: 137, Product: 27400, ST Level (mm), Slope (mV/sec) (-1.3/0.4, 0.2/1.5, 1.2/-0.5, -2.0/0.1, -2.5/3.3, -2.1/2.6, -1.7/2.2, -1.4/1.8, -1.3/2.1, -1.2/2.4, -1.7/1.5)

Recovery: Time: 10:59, BP: 170/80, HR: 127, Product: 21590, ST Level (mm), Slope (mV/sec) (-1.3/0.4, 0.6/1.5, 1.3/-0.5, -2.0/0.1, -1.5/3.3, -2.1/2.6, -1.5/2.2, -1.4/1.9, -1.3/2.1, -1.2/2.3, -1.7/1.5)

- **Physician Remarks and Conclusions:**

Reason for Test: Chest pressure

Reason for Ending Test: Fatigue

Conclusions: Normal blood pressure

GDT/BDT Type Communication

PC-ECG and HIS (Hospital Information System) Maintain Bi-Directional GDT/BDT Type Communication

- Import demographic data from HIS to PC-ECG
 - a. In setup, select **GDT/BDT**.
 - b. Check **Import from GDT/BDT**.
 - c. Define the GDT/BDT directory (in which the HIS file will be ready).
 - d. Define the first four characters of the **Token for PC-ECG** file.
This file always contains the last patient data.

- Export the GDT/BDT file from PC-ECG to HIS.
 - a. In setup, select **GDT/BDT**.
 - b. Check **Save Test in GDT/BDT**.
 - c. Define the GDT/BDT directory (in which PC-ECG file will be ready).
 - d. Define the first four characters of the **Token for Practice EDP** file.
This file always contains the last patient data.

DICOM Communication

The Norav PC-ECG 1200 is enabled for the following DICOM operations:

- Receive ECG orders using DICOM Modality Worklist (MWL).
- Store study reports as Encapsulated PDF files.
- Store Resting ECG study as 12-Lead ECG Waveform.
- Store Resting ECG reports in the Secondary Capture Image format.

Receive ECG orders from DICOM MWL

To enable MWL functionality in Resting ECG or Stress ECG:

- Start the Resting ECG/Stress ECG application and open the **Setup > Worklist** panel.
- Select the **Query DICOM MWL** option.
- Fill in the DICOM server connection parameters.
- Click **Apply**.



Note

It is recommended to set the **Modality** text field value to **ECG**. This ensures that **only ECG orders are received** from the DICOM MWL. If this field is left blank, **all types of orders** will be received, which may not necessarily be ECG-related. See the image below.

The screenshot shows the 'Worklist' configuration window. The 'Query DICOM MWL' section is highlighted with a red box. The fields are as follows:

MWL Server IP :	localhost
Port :	104
MWL Server AE Title :	MWL_SERVER
Station AE Title :	NORAV_ECG
Modality :	ECG
Lookup Days :	1

The 'Apply' button is highlighted with a red box at the bottom right.

Working:

Start a new patient, click **Worklist**, and select the patient's name from the list.

Store Encapsulated PDF reports to DICOM SCP

Supported in the Resting ECG and Stress ECG applications.

To enable the Encapsulated PDF report functionality:

- In **Resting ECG** software setup: open the **PDF\HL7 File\DICOM ECG** tab
In **Stress ECG** software setup: open the **PDF\XML\DICOM\RDT** tab
- Enable **Auto Save test Data in DICOM Encapsulated PDF**.
- Mark the **Store in PACS** checkbox.
- Fill the **PACS Server** connection details.
- Click **Apply**.

Setup

Leads | ECG Recording | Diagnosis | View | Installation | Environment | Picture Format | External Interface | TXT \ CSV
 FDA XML \ SCP \ McKesson format \ MFER format \ Raw Data Format | PDF \ HL7 File \ DICOM ECG | Worklist

PDF format

Auto Save test Data in PDF format

Entire study Final Page

Open PDF after recording

Set PDF File Name by:

Test File Name

Checked Fields

Delimiter: [v]

Order ID

Patient ID

Patient Last Name

Patient First Name

Patient Birth Date: dd-mm-yyyy

Date of Test: dd.mm.yyyy

Time of Test: hh:mm:ss

Test Type

PDF File Data Directory: C:\ProgramData\NoravMedical\PCECG\PDF

ECG Grid: Color Grid B&W Grid

DICOM ECG format

Auto Save test Data in DICOM ECG

Auto Save test Data in DICOM Encapsulated PDF

Auto Save test Data in DICOM Secondary Capture Image

DICOM File Data Directory: C:\ProgramData\NoravMedical\PCECG\Data

Validate patient in MWL

Update DCM Files

HL7 format

Auto Save test Data in HL7 format

With PDF report included

Set HL7File Name by:

Test File Name

Formatted file name (YYYYMMDDHHMMSSmSmSmS.hl7)

Configuration

Sending Application: NoravSender | Sending Facility: NoravFacil

Receiving Application: SomeApp | Receiving Facility: receivFacil

Provider (ID*Name): drkcode^andder

Observation Code (Code*Description): ECG^Norav Ecg

HL7 File Data Directory: C:\ProgramData\NoravMedical\PCECG\HL7

Store in PACS: Resend Files

PACS Server IP: []

Port: []

PACS Server AE Title: []

PACS Station AE Title: []

OK Cancel Apply

Store 12-lead ECG Waveforms to DICOM SCP

Supported in the Resting ECG application.

To enable the 12-lead ECG Waveform functionality:

1. In the **Resting ECG** setup open **PDF \ HL7 File \ DICOM ECG** tab.
2. Enable **Auto Save Test Data in DICOM ECG**.

Setup

Leads | ECG Recording | Diagnosis | View | Installation | Environment | Picture Format | External Interface | TXT \ CSV
 FDA XML \ SCP \ McKesson format \ MFER format \ Raw Data Format | PDF \ HL7 File \ DICOM ECG | Worklist

PDF format

Auto Save test Data in PDF format

Entire study Final Page

Open PDF after recording

Set PDF File Name by:

Test File Name

Checked Fields

Delimiter: [v]

Order ID

Patient ID

Patient Last Name

Patient First Name

Patient Birth Date: dd-mm-yyyy

Date of Test: dd.mm.yyyy

Time of Test: hh:mm:ss

Test Type

PDF File Data Directory: C:\ProgramData\NoravMedical\PCECG\PDF

ECG Grid: Color Grid B&W Grid

DICOM ECG format

Auto Save test Data in DICOM ECG

Auto Save test Data in DICOM Encapsulated PDF

Auto Save test Data in DICOM Secondary Capture Image

DICOM File Data Directory: C:\ProgramData\NoravMedical\PCECG\Data

Validate patient in MWL

Update DCM Files

HL7 format

Auto Save test Data in HL7 format

With PDF report included

Set HL7File Name by:

Test File Name

Formatted file name (YYYYMMDDHHMMSSmSmSmS.hl7)

Configuration

Sending Application: NoravSender | Sending Facility: NoravFacil

Receiving Application: SomeApp | Receiving Facility: receivFacil

Provider (ID*Name): drkcode^andder

Observation Code (Code*Description): ECG^Norav Ecg

HL7 File Data Directory: C:\ProgramData\NoravMedical\PCECG\HL7

Store in PACS: Resend Files

PACS Server IP: []

Port: []

PACS Server AE Title: []

PACS Station AE Title: []

OK Cancel Apply

3. Mark the **Store in PACS** checkbox.
4. Fill in the **PACS Server** connection details
5. Click **Apply**.

Store Resting ECG reports to DICOM Secondary Capture Image format

To enable the DICOM Secondary Capture Image export:

1. In **Resting ECG** setup: open the **PDF\HL7 File\DICOM ECG** tab. In **Stress ECG** setup: open the **PDF\XML\DICOM\RDT** tab.
2. Enable **Auto Save Test Data in DICOM Secondary Capture Image**.
3. Mark the **Store in PACS** checkbox.
4. Fill in the **PACS Server** connection details.
5. Click **Apply**.

The screenshot shows the 'Setup' dialog box with the 'DICOM ECG format' tab selected. The 'Auto Save test Data in DICOM Secondary Capture Image' checkbox is checked. The 'Store in PACS' checkbox is also checked. The PACS Server IP, Port, AE Title, and Station AE Title fields are visible and highlighted with red boxes. The 'Apply' button is also highlighted with a red box.

PDF format

Auto Save test Data in PDF format

Entire study Final Page

Open PDF after recording

Set PDF File Name by:

Test File Name

Checked Fields

Delimiter: [v]

Order ID

Patient ID

Patient Last Name

Patient First Name

Patient Birth Date [dd-mm-yyyy]

Date of Test [dd.mm.yyyy]

Time of Test [hh:mm:ss]

Test Type

PDF File Data Directory: [C:\ProgramData\NoravMedical\PCECG\PDF]

ECG Grid

Color Grid B&W Grid

HL7 format

Auto Save test Data in HL7 format

With PDF report included

Set HL7 File Name by:

Test File Name

Formatted file name (YYYYMMDDHHMMSmSmSmS.H17)

Configuration

Sending Application: [NoravSender] Sending Facility: [NoravFacil]

Receiving Application: [SomeApp] Receiving Facility: [receivFacil]

Provider (ID^Name): [dtk.code^andder]

Observation Code (Code^Description): [ECG^Norav Ecg]

HL7 File Data Directory: [C:\ProgramData\NoravMedical\PCECG\HL7]

DICOM ECG format

Auto Save test Data in DICOM ECG

Auto Save test Data in DICOM Encapsulated PDF

Auto Save test Data in DICOM Secondary Capture Image

DICOM File Data Directory: [C:\ProgramData\NoravMedical\PCECG\Data]

Validate patient in MWL

Update DCM Files

Store in PACS [Resend Files]

PACS Server IP: []

Port: []

PACS Server AE Title: []

PACS Station AE Title: []

OK Cancel **Apply**

Saving the Stress Test as a RAW Data (“native binary”) Format File

- Record a stress study
- Under File menu, create a RAW Data File.

A file with extension RDT is created, with the following structure:

(low byte, high byte) x 12 Leads x n samples (1sec = 500 samples).

Leads sentence - *I, II, III, AVR, AVL, AVF, V1, V2, V3, V4, V5, V6.*

Byte Number	Byte Type	Lead Number	Sample Number	Second Number
1	Lb	I	1	1
2	Hb			
3	Lb	II		
4	Hb			
...		
21	Lb	V5		
22	Hb			
23	Lb	V6		
24	Hb			
25	Lb	I	2	
26	Hb			
27	Lb	II		
28	Hb			
...		
45	Lb	V5		
46	Hb			
47	Lb	V6		
48	Hb			
...
$1+(n-1)*24$	Lb	I	n	n/500
$2+(n-1)*24$	Hb			
$3+(n-1)*24$	Lb	II		
$4+(n-1)*24$	Hb			
...		
$21+(n-1)*24$	Lb	V5		
$22+(n-1)*24$	Hb			
$23+(n-1)*24$	Lb	V6		
$n * 24$	Hb			

Table 30: Stress Raw Data File Format

Saving the Monitoring ECG Test as a Raw Data (“Native Binary”) Format File

- Record a Monitoring ECG study.
- Under File menu, create a RAW Data File.
A file with extension RDT is created, with the following structure:
Number Leads (low byte, high byte) + **Sample Rate** (low byte, high byte)
+ (low byte, high byte) x **Number Leads** x **n samples** (1sec = (sample rate)).

Byte Number	Byte Type	Lead Number	Sample Number	Second Number
1	Lb	1	1	1
2	Hb			
3	Lb	2		
4	Hb			
...		
2N -1	Lb	N		
2N	Hb			
2N +1	Lb	1	2	
2N +2	Hb			
2N +3	Lb	2		
2N +4	Hb			
...		
2N*2-1	Lb	N		
2N*2	Hb			
...
1+(n-1)*2N	Lb	1	n	n/ (sample rate)
2+(n-1)*2N	Hb			
3+(n-1)*2N	Lb	2		
4+(n-1)*2N	Hb			
...		
2N*n-1	Lb	N		
2N*n	Hb			

Table 31: Monitoring ECG Raw Data file format

TECHNICAL SPECIFICATIONS

Feature	Model					
	1200M	1200S	1200HR	1200W	Blue-ECG	NR-1207-E, NR-1207-3
Size (mm)	128 x 75 x 27		170 x 90 x 30	140 x 95 x 50	125 x 65 x 22	92 x 75 x 23
Weight (gram)	200		300	350	100	103
Power	USB 5V± 5%			2x AA alkaline or NiMH rechargeable		1x AA alkaline or NiMH rechargeable
USB current consumption	<100mA± 10%		<200mA± 10%	<60mA± 10% (in 1200WR adapter)	n/a	
Battery Operation Time	n/a			Up to 40 hours (with alkaline batteries)	Up to 12 hours	Up to 7 hours
Patient leads	Standard 10 lead AHA/IEC cable		Standard 10 lead, or 14 lead AHA/IEC cable	Detachable 10 wires conform to AAMI	Standard 10 lead cable AHA/IEC	
Lead OFF detection	n/a		Detached Lead or Offset >0.5 V			
Pacemaker Pulse detection	n/a		From 0.1 to 2 ms at 2 to 700 mV			
Sampling rate of digital pacemaker detection	n/a		8000 samples/sec		n/a	
Sensitivity (mm/mV)	5, 10, 20, 40					
Horizontal scale(mm/sec)	12.5, 25, 50, 100	5, 12.5, 25, 50, 100			12.5, 25, 50, 100	
ECG Max. sample rate	1000 samples/sec					
Resting ECG	1000 samples/sec					
Stress ECG	1000 samples/sec					
Monitoring ECG	n/a		2000 samples/sec (12 lead) 4000 samples/sec (6 lead)	1000 samples/sec	n/a	
Resolution A/D	12 bits (2.44 µV/LSB)	12 bits (4.88 µV/LSB)	24 bits (0.3 µV/LSB)	24 bits (0.286 µV/LSB)	12 bits (2.44 µV/LSB)	
Defibrillation protection	Yes, protected against 360 J discharge					Yes, with Banana type ECG cable
Patient leakage current	<10 µA					
Simultaneously 12L	Yes					
CMRR	> 90 dB					
Input impedance	> 10 MOhm					
Signal dynamic range	10mV	20mV	± 2.4 V		10mV	
DC max. input	± 300mV		± 2.4 V		± 300mV	± 800mV
Frequency range (-3db)	0.05 – 150 Hz		0.05 - 300 Hz	0.05 – 260 Hz	0.05 – 150 Hz	0.05 – 260 Hz
Low pass filter (software)	20, 35, 40, 100 Hz					
Base line filter (software)	Yes					
Line noise filter (software)	50/60Hz					
Communication interface	USB			Digital RF, up to 10 m in open space	Bluetooth 2.1+EDR, Class1 up to 100 m in open space	
Radio frequency range	n/a			2400 – 2483.5 MHz		
RF output power	n/a			0.4 mW, conform to FCC	100 mW, conform to FCC	
Transport & Storage temperature	-20°C to +60°C					
Operating temperature	10°C to +45°C					
Relative Humidity	10 to 95%					
Safety standard	IEC 60601-1, IEC 60601-1-2, IEC 60601-2-25				IEC 60601-1-2	IEC 60601-1, IEC 60601-1-2, IEC 60601-2-25

Table 32: Technical specifications

REPORT SAMPLES

BP: 80/120

HR: 86

Signature: _____	
ID:	I2
Last Name:	Wortenberg
First Name:	Hans
Birth Date:	05/01/1977
Age:	27
Sex:	M
Weight (kg):	78.00

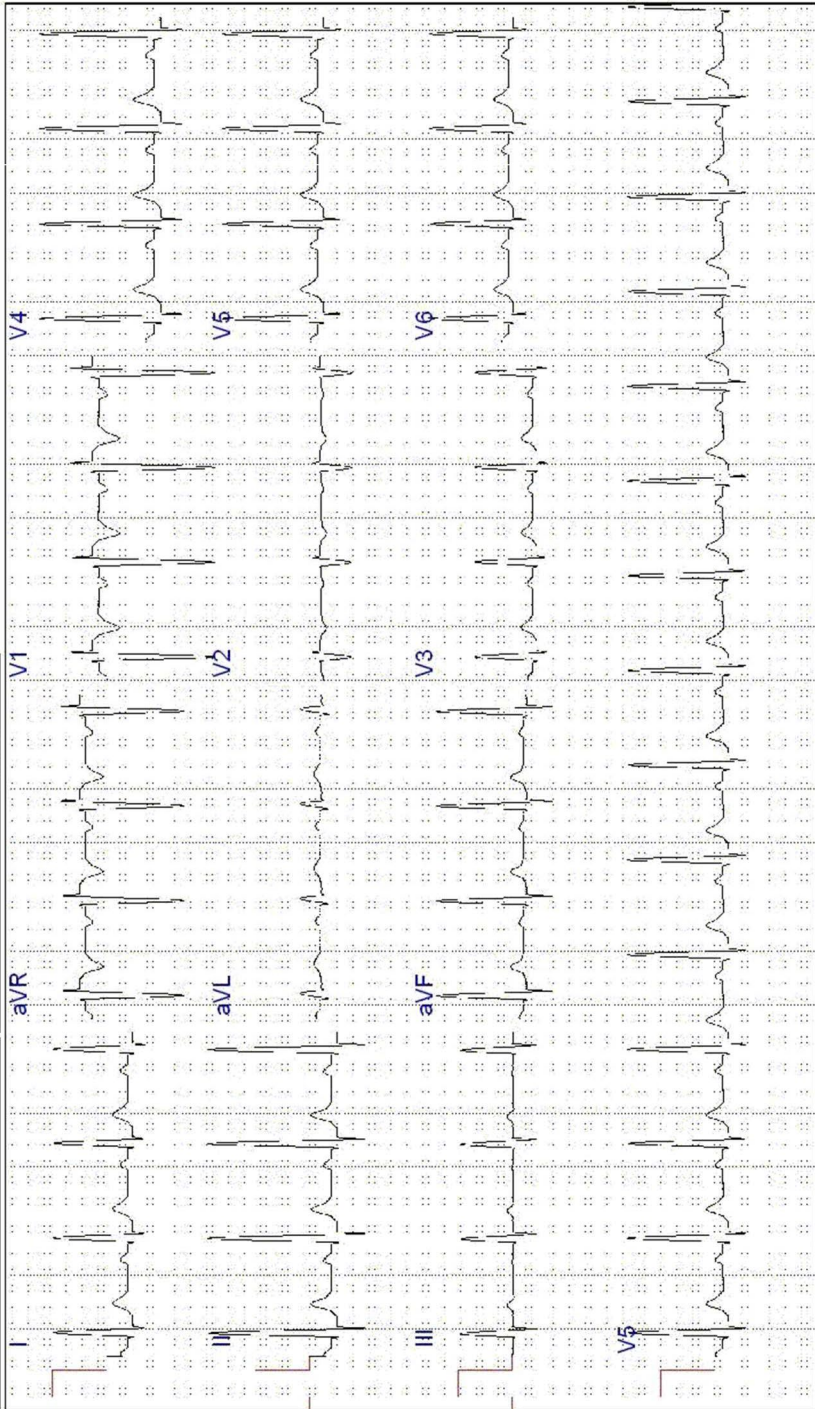

Nonav Medical Ltd. rev. 4. 6. 0

January 06, 2004 10:27

2.5 mm/sec 10 mm/mV Filters: 50 Hz -off; BL -off; 0.05 -150 Hz

Figure 59: Rest Report

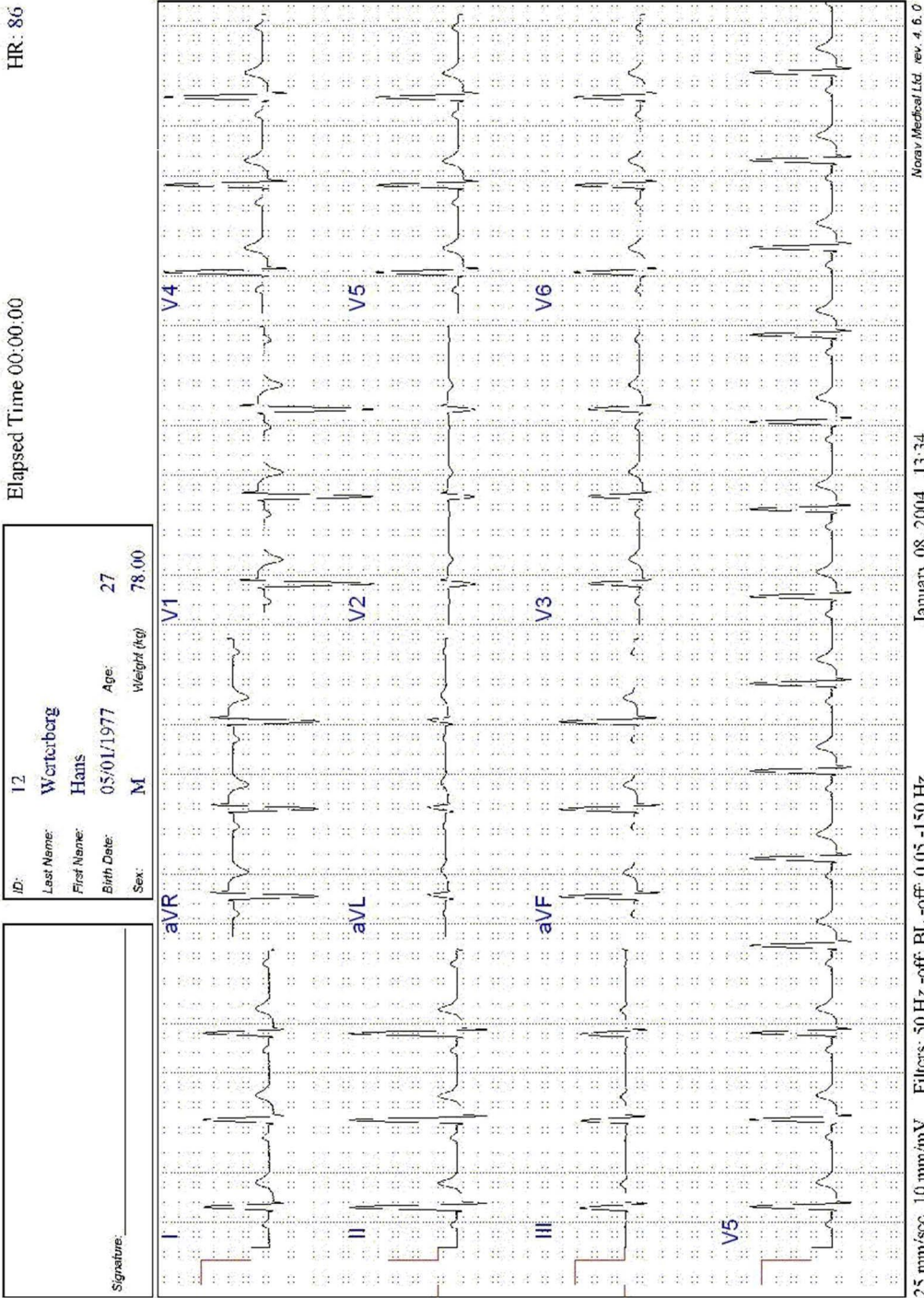

Figure 61: Monitoring ECG Report

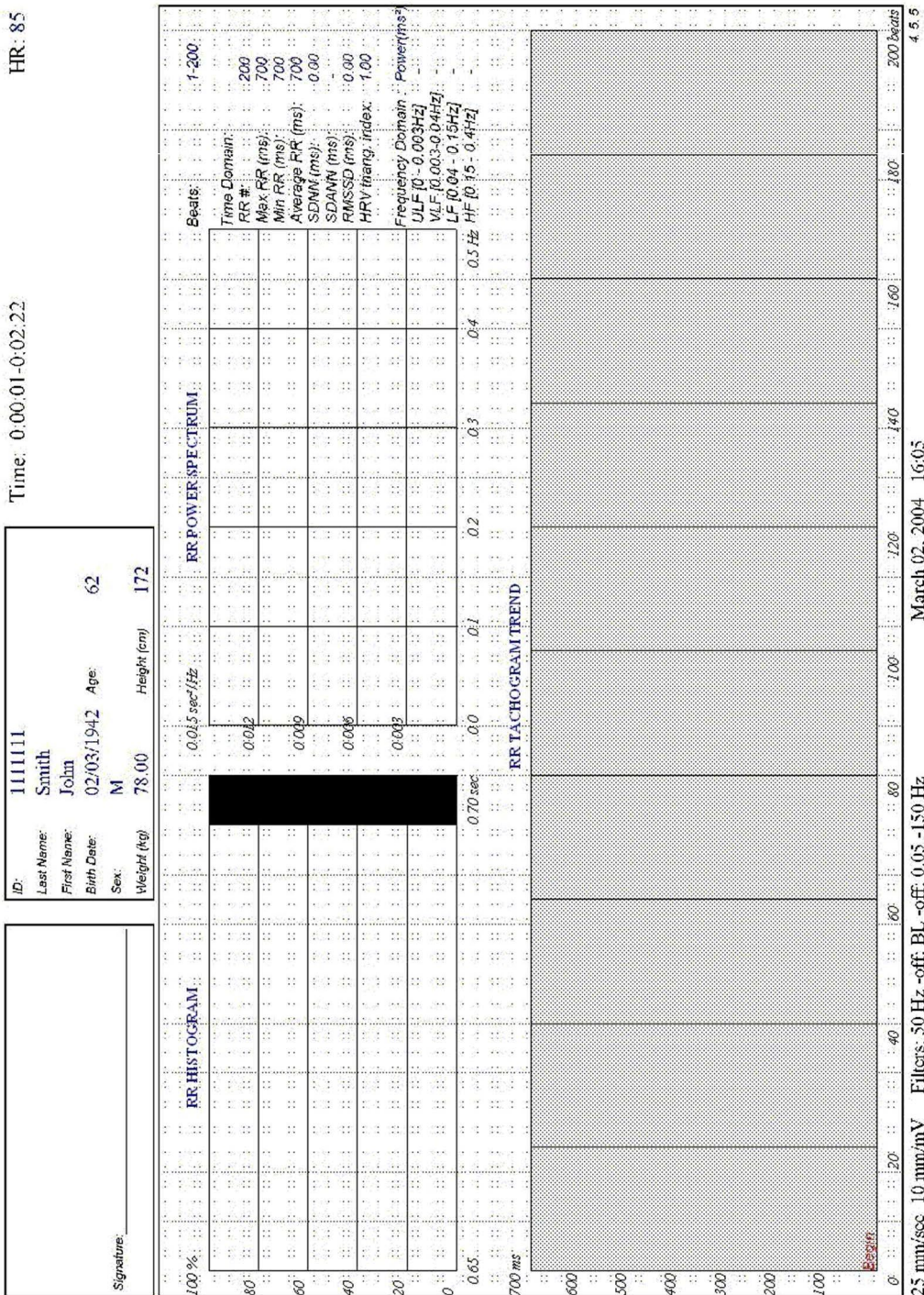

Figure 62: Heart Rate Variability Report

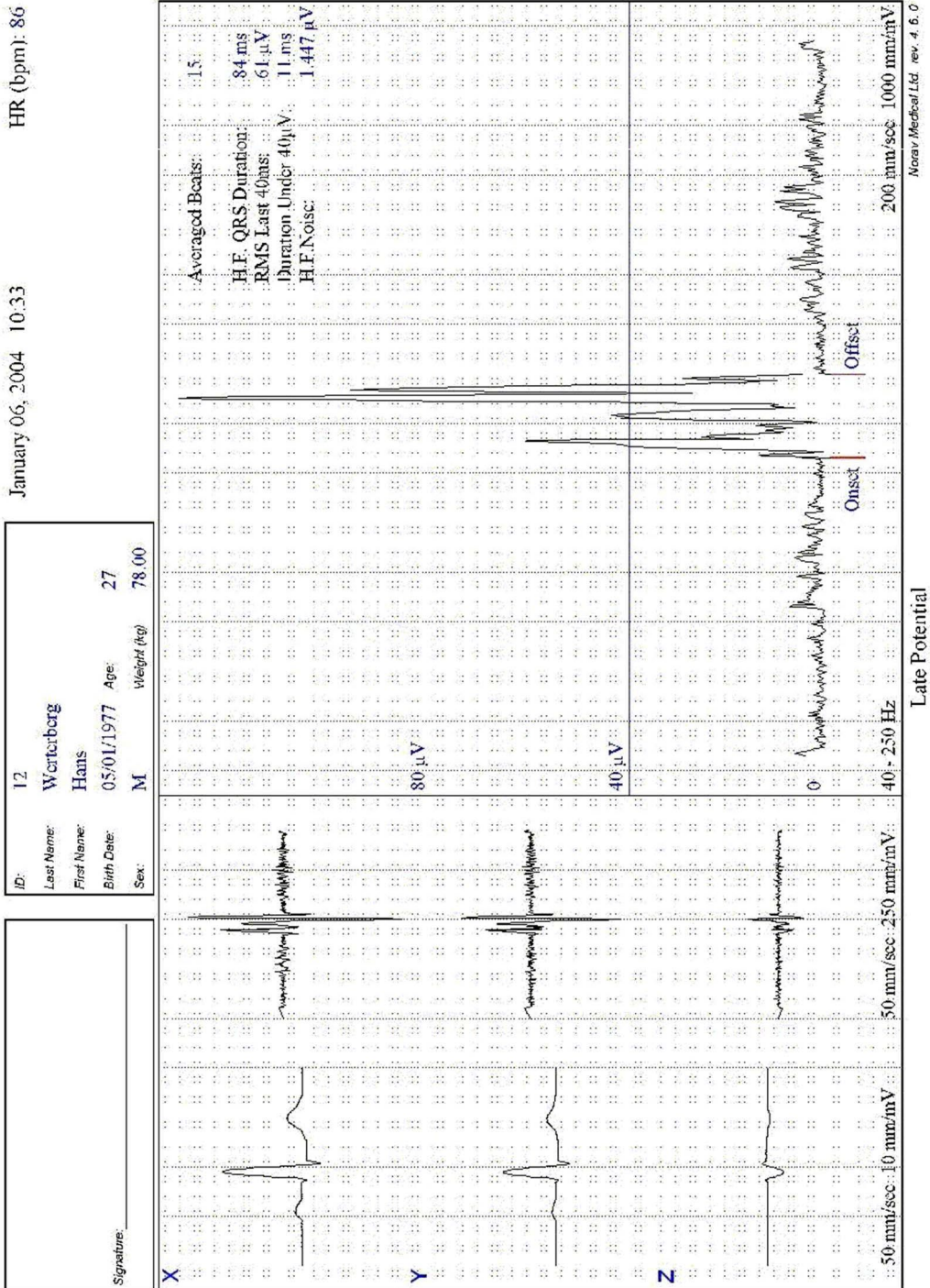

Figure 63: Late Potential Report

TROUBLESHOOTING

<u>Condition</u>	<u>Causes</u>	<u>Action</u>
USB Driver is not installed properly during PC-ECG Installation	If you connect the device to the PC via the USB before to start the software installation CD, the USB driver might be not installed.	<ul style="list-style-type: none"> • Disconnect the USB cable. • Install the PC-ECG 1200 software from the CD-ROM. • Connect the device to USB port • Check if the driver is now installed correctly (the LED on the device is on). • If the device is still not correctly installed, then uninstall the unidentified USB driver as follows: <ol style="list-style-type: none"> a. While still connected to the USB, right click My Computer. b. Select Properties from the pop-up menu. c. Click Device Manager on the Hardware tab. d. Double click the USB Device with the ? icon in the list of devices. e. Select Driver tab. f. Click Uninstall and then OK. • After the driver is deleted, disconnect the USB cable from the PC. • Install the PC-ECG software and continue to the next step. • Reconnect the USB cable to the computer connector. • Wait until the driver is installed and the green light is illuminated on the device
Recovering ECG Data after Unexpected Shutdown of the Stress Application	If the application terminates unexpectedly before the ECG test is completed and saved, it may be possible to recover the ECG data of the (exhausted [??]) patient.	<p>Stress ECG application stores native ECG data in the temporary file. You can convert this data into Monitoring ECG application file format as follows:</p> <ul style="list-style-type: none"> • Start the Stress ECG application. • Click Recovery File to Monitoring Format... in the File main menu. The Choose files for conversion... dialog box is displayed. • Select the Windows\Temp folder. • Select strXX.tmp last created temporary file and click Open. • Select the Monitoring ECG files folder. • Insert monitoring ECG file name according to patient ID or last name and click Save. • Close the Stress ECG application. • Open the Monitoring ECG files folder and double click on the last stored file. The monitoring ECG application opens.

<u>Condition</u>	<u>Causes</u>	<u>Action</u>
		<ul style="list-style-type: none"> • Click the Patient main menu button and insert patient data. • Save the updated Monitoring ECG file. You can now inspect and print ECG strip from the Monitoring ECG application.
Working in AutoSave Mode Without Saving Modifications		<p>If you perform modifications (adds/edit remarks, measurements, recalculations, etc...) while in AutoSave mode, but do not wish to save the modifications, do the following:</p> <ul style="list-style-type: none"> • Click Setup. • Uncheck Auto Save option and click OK. • Close the application (or the file) with the X button. A dialog box is displayed requesting acknowledgement for the save. • Click No. • Reopen the application and the file. • Check that modifications were not saved. • It is now safe to re-enable the Auto Save mode (if required).
A Thick Straight Line is Displayed For All Leads	A thick straight line appears on screen for all leads when the connection to the acquisition box fails.	<p>When using USB connection, check that the led on the ECG device is illuminated. If the led on ECG device is not illuminated, check connections to the USB port and to the ECG device.</p> <p>If the led on the USB adapter is illuminated or if connected through RS232, check the connection to the acquisition box and make sure the box is switched on.</p>
Noisy ECG Signal on Leads	A noisy ECG signal on one or more of the leads may be caused due to poor connection of the appropriate electrodes or leads on the patient.	Check the connection of the appropriate leads on the patient Make sure the electrodes are applied OK on the patient.

Condition	Causes	Action
Missing data after a thick line	On the screen and in printouts of the ECG, appears for a few seconds a thick strait line and after that there is missing data for a period of time. The ECG traces resume after this random period of time. This problem may be caused due sleep mode or hibernation mode the PC entered while the ECG test was running.	Any settings related to the power management should be disabled: no standby, no stop HD, no hibernation, etc... on the laptop during the Stress test. To set the power management do the following: <ul style="list-style-type: none"> • Right click on the desktop. • Select PROPERTIES form the pop-up menu. • Select SCREENSAVER tab. • Press on POWER button in the Monitor Power frame. • Select Power Schemes as either PRESENTATION or HOME\OFFICE DESK. • Set NEVER to "Turn off Hard Disk", "System Standby" and "System Hibernates". • Press OK to apply this configuration.
“Lead-off” is displayed on the screen or some leads prints as a bold lines	Electrode contact is poor. A lead may be loose. A lead is disconnected from the patient. Broken lead wire or patient cable,	Reattach the electrode. Replace the electrode. Verify that the patients’ skin is properly prepared. Verify that shelf life of electrodes is not expired
Muscle tremor interference superimposed on waveforms.	<ul style="list-style-type: none"> • Patient is uncomfortable. • Patient is cold and shivering. • Exam bed is too small or narrow. • Electrode straps are tight. 	<ul style="list-style-type: none"> • Help patient get comfortable. • Check all electrode contacts. • Turn the EMG filter on.
AC interference superimposed on waveforms.	Electrodes problem. Technician touching an electrode Patient touching any metal parts of an exam table or bed. Broken ECG cable, or power cord. Electrical devices in the immediate area, lighting, concealed wiring in walls or floors. Improperly grounded electrical outlet. Incorrect AC filter frequency setting or AC filter is turned off.	Verify that the patient is not touching any metal parts of the bed or environment. Verify that the AC power cable is not intertwined with the patient lead cable. <ul style="list-style-type: none"> • Turn the AC filter on. • Verify that the proper AC filter setting is selected (50Hz or 60Hz, depends on your region). • If interference still persists, the noise may be caused by other equipment in the room or by poorly grounded power lines. • Try moving to another room.